

# User's Manual



**CXC-PM855**

**MSC COM Express Module  
Celeron M/ Pentium M**

**– PRELIMINARY –**

Rev. 0.7  
March 20<sup>th</sup>, 2008



**MICROCOMPUTERS · SYSTEMS · COMPONENTS · VERTRIEBS GMBH**

*... embedding excellence*

## Preface

### Copyright Notice

Copyright © 2008 MSC Vertriebs GmbH. All rights reserved.

Copying of this document, and giving it to others and the use or communication of the contents thereof, are forbidden without express authority. Offenders are liable to the payment of damages.

All rights are reserved in the event of the grant of a patent or the registration of a utility model or design.

### Important Information

This documentation is intended for qualified audience only. The product described herein is not an end user product. It was developed and manufactured for further processing by trained personnel.

### Disclaimer

Although this document has been generated with the utmost care no warranty or liability for correctness or suitability for any particular purpose is implied. The information in this document is provided "as is" and is subject to change without notice.

### EMC Rules

This unit has to be installed in a shielded housing. If not installed in a properly shielded enclosure, and used in accordance with the instruction manual, this product may cause radio interference in which case the user may be required to take adequate measures at his or her own expense.

### Trademarks

All used product names, logos or trademarks are property of their respective owners.

### Certification

MSC Vertriebs GmbH is certified according to DIN EN ISO 9001:2000 standards.

### Life-Cycle-Management

MSC products are developed and manufactured according to high quality standards. Our life-cycle-management assures long term availability through permanent product maintenance. Technically necessary changes and improvements are introduced if applicable. A product-change-notification and end-of-life management process assures early information of our customers.

### Product Support

MSC engineers and technicians are committed to provide support to our customers whenever needed.

Before contacting Technical Support of MSC Vertriebs GmbH, please consult the respective pages on our web site at [www.msc-ge.com/support-boards](http://www.msc-ge.com/support-boards) for the latest documentation, drivers and software downloads.

If the information provided there does not solve your problem, please contact our Technical Support:

Email: [support.boards@msc-ge.com](mailto:support.boards@msc-ge.com)

Phone: +49 8165 906-200

# Content

|         |   |    |
|---------|---|----|
| 1       | General Information .....                                   | 5  |
| 1.1     | Revision History.....                                       | 5  |
| 1.2     | Introduction.....   | 5  |
| 2       | Technical Information.....                                  | 6  |
| 2.1     | Specifications .....  | 6  |
| 2.2     | Block Diagram .....   | 9  |
| 2.3     | Installation .....  | 12 |
| 2.3.1   | Jumpers and switches.....                                   | 12 |
| 2.3.2   | Installing a DDR SO-DIMM module .....                       | 12 |
| 2.4     | Watchdog .....  | 13 |
| 2.5     | Interrupts, DMA channels, Upper memory .....                | 14 |
| 2.5.1   | IRQs.....   | 14 |
| 2.5.2   | PCI Devices .....   | 15 |
| 2.5.3   | SMBus address map.....                                      | 16 |
| 3       | Mechanical Specification.....                               | 17 |
| 3.1     | Top view .....  | 17 |
| 3.2     | Bottom view.....  | 17 |
| 3.3     | Mechanical drawing.....                                     | 18 |
| 3.3.1   | Heat spreader options.....                                  | 19 |
| 4       | Cooling concept .....                                       | 20 |
| 5       | Connectors .....  | 21 |
| 5.1     | Rows A and B.....   | 22 |
| 5.2     | Rows C and D .....  | 26 |
| 6       | BIOS .....  | 29 |
| 6.1     | Introduction.....   | 29 |
| 6.1.1   | BIOS Version .....  | 29 |
| 6.1.2   | Startup Screen Overview .....                               | 29 |
| 6.1.3   | Activity Detection Background.....                          | 30 |
| 6.2     | FirstBIOS Pro Setup Utility .....                           | 31 |
| 6.2.1   | The Main Menu .....   | 31 |
| 6.2.1.1 | Main Menu Selections.....                                   | 33 |
| 6.2.1.2 | Masters and Slaves .....                                    | 34 |
| 6.2.1.3 | Boot Options.....   | 36 |
| 6.2.2   | The Advanced Menu .....                                     | 37 |
| 6.2.2.1 | Advanced Menu Selections.....                               | 37 |
| 6.2.2.2 | I/O Device Configuration Menu .....                         | 39 |
| 6.2.2.3 | Advanced Chipset Control Menu .....                         | 40 |
| 6.2.2.4 | Video (Intel IGD) Control Sub-Menu .....                    | 41 |
| 6.2.2.5 | Cache Memory Control Menu .....                             | 42 |
| 6.2.2.6 | PCI Configuration Menu.....                                 | 43 |
| 6.2.2.7 | PCI/PNP ISA UMB Region Exclusion Configuration Menu.....    | 44 |
| 6.2.2.8 | PCI/PNP ISA IRQ Resource Exclusion Configuration Menu ..... | 45 |
| 6.2.3   | The Security Menu .....                                     | 46 |
| 6.2.4   | The Power Menu.....   | 47 |
| 6.2.4.1 | Power Menu Selections .....                                 | 47 |
| 6.2.4.2 | ACPI Control Sub-Menu .....                                 | 48 |
| 6.2.4.3 | CPU Control Sub-Menu .....                                  | 49 |
| 6.2.4.4 | MCH Control Sub-Menu.....                                   | 50 |
| 6.2.4.5 | Hardware Monitoring Menu.....                               | 51 |
| 6.2.4.6 | Temperature Management Menu.....                            | 52 |
| 6.2.5   | The Boot Menu.....  | 53 |
| 6.2.6   | The Exit Menu.....  | 54 |
| 6.2.6.1 | Exit Saving Changes.....                                    | 54 |
| 6.2.6.2 | Exit Discarding Changes.....                                | 54 |

6.2.6.3 Load Setup Defaults ..... 54  
6.2.6.4 Discard Changes ..... 55  
6.2.6.5 Save Changes ..... 55

# 1 General Information

## 1.1 Revision History

| Rev. | Description                                       |
|------|---|
| 0.1  | Initial version                                   |
| 0.2  | BIOS chapter included; new formatting             |
| 0.3  | Formatting  |
| 0.4  | Power supply current added                        |
| 0.5  | Memory table removed                              |
| 0.6  | Page 23: yellow markings of USB4 and USB5 removed |
| 0.7  | Preface added                                     |

## 1.2 Introduction

COM Express™, an open specification of the PICMG (PCI Industrial Computer Manufacturer Group), is a module concept to bring PCI Express and other latest technologies like SATA, USB 2.0 and LVDS on a COM (Computer On Module).

A COM Express™ module is plugged onto an application-specific base board similar in the ETX concept, but offers more options and a growth path to future CPU technologies.

Utilizing different sizes, COM Express can be used for highly embedded solutions up to high performance platforms.

The design of the MSC CXC-PM855 modules supports all current variants of the Intel® Embedded Pentium® M processor up to the latest version with 400 MHz FSB.

For evaluation and design-in of the COM Express™ modules we provide evaluation baseboards and develop motherboards providing the interface infrastructure for the COM Express™ module and offering PC plug connectors for external connection.

Support for Windows® CE and Linux can be offered on request.

### Note:

To date the Compact format is not an official part of the currently active COM Express specification. This specification defines some minimum requirements for a COM express module (Basic and Extended format). The MSC CXC-PM855 cannot support some of these requirements (PCI Express, SATA and SDVO) because the chipset does not provide these functions.

## 2 Technical Information

### 2.1 Specifications

#### Core

|                |  |
|----------------|--|
| <b>CPU</b>     | Intel Pentium M ( $\mu$ FCBGA, soldered) :<br>Celeron M 600MHz up to Pentium M 1.8 GHz               |
| <b>ChipSet</b> | Intel <sup>®</sup> GMCH: Intel <sup>®</sup> 82855GME or 82852GM<br><br>Intel <sup>®</sup> 82801 ICH4 |

|                 |   |
|-----------------|---|
| <b>L2 Cache</b> | 512KB (Celeron M) up to 2MB (Pentium M) |
|-----------------|---|

|               |  |
|---------------|--|
| <b>Memory</b> | 200-pin SO-DIMM socket for up to 1GB<br>PC2700 DDR SDRAM (DDR333) for 82855GME<br>PC2100 DDR SDRAM (DDR266) for 82852GM<br>ECC possible with ECC-SODIMM (82855GME option only) |
|---------------|--|

|                              |  |
|------------------------------|--|
| <b>COM Express Interface</b> | Typ 2 interface subset with PCI and IDE<br><br>PCI Express , SATA and SDVO not supported |
|------------------------------|--|

|                                  |  |
|----------------------------------|--|
| <b>PCI Express Bus Interface</b> | No PCI Express signals due to used chipset |
|----------------------------------|--|

|                          |   |
|--------------------------|---|
| <b>PCI-Bus Interface</b> | 32 bit standard interface (Intel <sup>®</sup> 82801 ICH4) |
|--------------------------|---|

|              |   |
|--------------|---|
| <b>Video</b> | Integrated 4x AGP VGA Controller:<br>Intel <sup>®</sup> Extreme Graphics2 (integrated in Intel <sup>®</sup> 855 GM Chipset) <ul style="list-style-type: none"> <li>▪ UMA, up to 32MB</li> <li>▪ LVDS (two 24bit channels)<br/>18/24/36/48-bit max. resolution 1.600 x 1.200</li> <li>▪ CRT Interface Max. resolution 2.048 x 1.536</li> </ul> |
|--------------|---|

|                 |   |
|-----------------|---|
| <b>Ethernet</b> | Integrated 10/100Base-T LAN Controller Intel <sup>®</sup> 82551ER |
|-----------------|---|

|              |   |
|--------------|---|
| <b>Audio</b> | AC'97 (integrated in Intel <sup>®</sup> 82801 ICH4) |
|--------------|---|

|            |   |
|------------|---|
| <b>USB</b> | integrated in Intel <sup>®</sup> 82801 ICH4:<br>6 USB 1.1/2.0 ports |
|------------|---|

|             |  |
|-------------|--|
| <b>EIDE</b> | integrated in Intel <sup>®</sup> 82801 ICH4:<br>1 port for up to 2 devices (master, slave)<br>Ultra ATA/66/100 |
|-------------|--|

|                       |   |
|-----------------------|---|
| <b>Realtime Clock</b> | integrated in 82801 ICH4<br>(external battery on carrier board is required) |
|-----------------------|---|

|  |  |
|--|--|
| <b>Watchdog Timer</b>                                    | Creates system reset (programmable, 1s ... 255h)<br><br>Start delay and timeout configurable via SETUP<br>creates hardware reset   |
| <b>BIOS</b>  | Phoenix cME FirstBIOS Embedded Pro in 1024 KB Flash device <ul style="list-style-type: none"> <li>▪ Auto Configuration: Plug &amp; Play (PCI), PCI Auto Configuration (PCI 2.1), Automatic DRAM configuration</li> <li>▪ Boot Options: Quick Boot, MultiBoot (FD, HD, CD, LAN, USB), Boot without keyboard</li> <li>▪ Security: System and setup password, Write protection for BIOS Flash</li> <li>▪ Power Management: APM, ACPI, Fixed frequency option (Setup), Geyserville 3 Support</li> <li>▪ USB: USB legacy support (Keyboard, Mouse, Hub)</li> <li>▪ Video: VGA Bios with flat panel extensions</li> <li>▪ Flash Update :BIOS update via storage media</li> <li>▪ Setup: CMOS setup backup in EEPROM chip</li> <li>▪ LAN Boot: RPL PXE extension</li> </ul> |
| <b>EEPROM</b>  | EEPROM for CMOS Setup backup   |
| <b>System Monitoring</b>                                 | 2 temperatures (CPU (MAX1618) and board (W83L786R))<br>5 voltages (Vcore, +2.5V, +3.3V, +1.5V, +1.05V)   |
| <b>Power supply</b>                                      | +12V $\pm$ 5%<br><br>+5V StandBy $\pm$ 5%  |
| <b>Typical supply current (DOS prompt, 256MB memory)</b> | Celeron M 600MHz: 0.90A @ 12V (10.8W)<br>Celeron M 1GHz: 0.85A @ 12V (10.0W)<br>Pentium M 1.4GHz: 1.20A @ 12V (14,0W);<br>1.5W in Suspend mode<br>Pentium M 1.8GHz: 2.10A @ 12V (25,0W)  |
| <b>CMOS battery power consumption</b>                    | max . 5 $\mu$ A at +3.0V   |
| <b>Environment</b>                                       | Temperature<br><br>0 ... + 60°C (operating),<br>-25 ... + 85°C (non operating)<br><br>Humidity (rel.)  |

0 ... 95 % (operating),  
5 ... 95 % (non operating)

**Dimensions** 95mm x 95mm x 17mm (with heat spreader)

**Heat Spreader** 95mm x 95mm x 3mm with through hole standoffs (3mm) or  
threaded corner standoffs (2.5mm)

**Note:**

A heat spreader plate is available from MSC providing a standard thermal interface for the module.

**The heat spreader is not a heat sink!**

## 2.2 Block Diagram

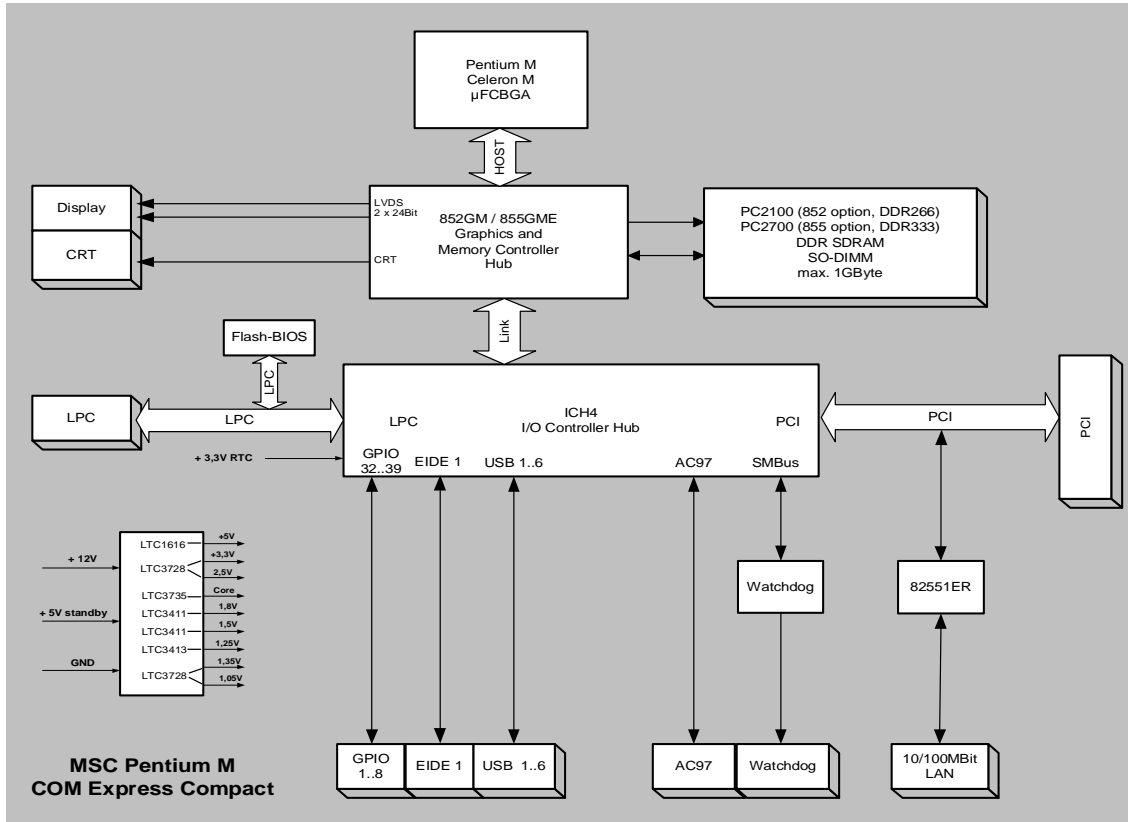

## 2.3 COM Express implementation

To date the Compact format is not an official part of the currently active COM Express specification. This specification defines some minimum requirements for a COM express module (Basic and Extended format). The MSC CXC-PM855 cannot support some of these requirements (PCI Express, SATA and SDVO) because the chipset does not provide these functions. Please check the following table for available functions.

The column MSC CXC-PM855 shows the implemented features of the MSC module:

|   | Type 2    | MSC<br>CXC-PM855 | Note                          |
|---|-----------|------------------|-------------------------------|
|   | Min / Max |                  |                               |
| <b>System I/O</b>                             |           |                  |                               |
| PCI Express Graphics (PEG)                    | 0 / 1     | 0                | not implemented               |
|   |           |                  |                               |
| PCI Express Lanes 0 - 5                       | 2 / 6     | 0                | not implemented               |
| PCI Express Lanes 16-31<br>(same as PEG pins) | 0 / 16    | 0                | not implemented               |
|   |           |                  |                               |
| SDVO Channels                                 | 0 / 2     | 0                | not implemented               |
| LVDS Channels                                 | 0 / 2     | 2                | 1x dual channel, 2x24 Bit     |
| VGA Port                                      | 0 / 1     | 1                |                               |
| TV-Out  | 0 / 1     | 0                | not implemented               |
| PATA Port                                     | 1 / 1     | 1                |                               |
| SATA / SAS Ports                              | 2 / 4     | 0                | not implemented               |
| AC'97 Digital Interface                       | 0 / 1     | 1                | AC97 or High Definition Audio |
| USB 2.0 Ports                                 | 4 / 8     | 6                |                               |
| LAN 0 (10/100Base-T min)                      | 1 / 1     | 1                |                               |
| PCI Bus - 32 Bit                              | 1 / 1     | 1                |                               |
|   |           |                  |                               |
| Express Card Support                          | 1 / 2     | 0                | not implemented               |
| LPC Bus                                       | 1 / 1     | 1                |                               |
| System Management                             |           |                  |                               |
| General Purpose Inputs                        | 4 / 4     | 4                |                               |
| General Purpose Outputs                       | 4 / 4     | 4                |                               |

|                           | Type 2 | MSC<br>CXC-PM855 | Note |
|---------------------------|--------|------------------|------|
| SMBus                     | 1 / 1  | 1                |      |
| I2C                       | 1 / 1  | 1                |      |
| Watch Dog Timer           | 0 / 1  | 1                |      |
| Speaker Out               | 1 / 1  | 1                |      |
| External BIOS ROM support | 0 / 1  | 1                |      |
| Reset Functions           | 1 / 1  | 1                |      |
| Power Management          |        |                  |      |
| Thermal Protection        | 0 / 1  | 1                |      |
| Battery Low Alarm         | 0 / 1  | 1                |      |
| Suspend                   | 0 / 1  | 1                |      |
| Wake                      | 0 / 2  | 2                |      |
| Power Button Support      | 1 / 1  | 1                |      |
| Power Good                | 1 / 1  | 1                |      |
|                           |        |                  |      |
| TPM                       | 0 / 0  | 0                |      |

## 2.4 Installation

### 2.4.1 Jumpers and switches

There are no jumpers or switches.

### 2.4.2 Installing a DDR SO-DIMM module

The CXC-PM855 board has a standard 200-pin DDR SO-DIMM socket for 2,5V DDR SO-DIMM modules for up to

- 1GB PC2700 DDR SDRAM (DDR333, 82855GME option) or
- 1GB PC2100 DDR SDRAM (DDR266, 82852GM option)

**Notes:** Module height should not exceed 1250mil (= 31.75 mm)  
ECC is not supported by the 82852GM option

## 2.5 Watchdog

The COM Express board has a watchdog function implemented using a PIC microcontroller with an SMBus interface. Via SETUP the watchdog can be enabled and configured.

If the watchdog is enabled a counter is started which creates a reset if it is not retriggered within a programmable time window.

Watchdog :        Enabled / **Disabled (default)**  
Initial Delay :    1s, 5s, 10s, **30s (default)**, 1min, 5min, 10min, 30min  
Timeout :         0,4s, 1s, 5s, 10s, **30s (default)**, 1min, 5 min, 10min  
Start on Boot:    if yes, watchdog starts at the end of POST (power on selftest)  
                     before the OS is loaded

The watchdog is accessible via the software UEFI-Interface.

## 2.6 Ressource allocation

### 2.6.1 IRQs

| IRQ | used for               | available | comment |
|-----|------------------------|-----------|---------|
| 0   | Timer 0                | No        |         |
| 1   | Keyboard               | No        |         |
| 2   | Slave 8259             | No        |         |
| 3   | COM2                   | No        | (1)     |
| 4   | COM1                   | No        | (1)     |
| 5   | Audio / LPT2           | Yes       | (1)     |
| 6   | Floppy Disk Controller | No        | (1)     |
| 7   | LPT1                   | No        | (1)     |
| 8   | Real Time Clock        | No        |         |
| 9   | PCI                    | Yes       | (1)     |
| 10  | PCI / COM3             | Yes       | (1)     |
| 11  | PCI / COM4             | Yes       | (1)     |
| 12  | PS/2 Mouse             | No        | (1)     |
| 13  | Floating Point Unit    | No        |         |
| 14  | Primary IDE            | No        | (1)     |

(1) If the device is disabled in SETUP, the interrupt is available.

## 2.6.2 PCI devices interrupt table

|                                    |                         |       | Interrupts of Controller (ICH-4) |                   |                   |                   |                   |                   |                   |                   |                      |
|------------------------------------|-------------------------|-------|----------------------------------|-------------------|-------------------|-------------------|-------------------|-------------------|-------------------|-------------------|----------------------|
| Slot Number<br>(or Onboard Device) | IDSEL #<br>or<br>DEV. # | Bus # | PIRQ 0<br>(INT A)                | PIRQ 1<br>(INT B) | PIRQ 2<br>(INT C) | PIRQ 3<br>(INT D) | PIRQ 4<br>(INT E) | PIRQ 5<br>(INT F) | PIRQ 6<br>(INT G) | PIRQ 7<br>(INT H) |                      |
| Slot 0                             | AD19 /<br>Dev 03h       | 2     |                                  |                   |                   |                   | D                 | A                 | B                 | C                 | Interrupts of Device |
| Slot 1                             | AD20 /<br>Dev<br>04h    | 2     |                                  |                   |                   |                   | A                 | B                 | C                 | D                 |                      |
| Slot 2                             | AD21 /<br>Dev 05h       | 2     |                                  |                   |                   |                   | B                 | C                 | D                 | A                 |                      |
| Slot 3                             | AD22 /<br>Dev 06h       | 2     |                                  |                   |                   |                   | C                 | D                 | A                 | B                 |                      |
| Slot 4                             | AD23 /<br>Dev 07h       | 2     |                                  |                   |                   |                   | D                 | A                 | B                 | C                 |                      |
| LAN<br>Controller                  | AD29 /<br>Dev 0Dh       | 2     | --                               | A                 | --                | --                | --                | --                | --                | --                |                      |
| Internal<br>Graphic<br>Device      | Dev 02h                 | 0     | A                                | --                | --                | --                | --                | --                | --                | --                |                      |
| Internal<br>USB 1.1<br>Controller  | Dev 1Dh<br>Fkt 0        | 0     | A                                | --                | --                | --                | --                | --                | --                | --                |                      |
| Internal<br>USB 1.1<br>Controller  | Dev 1Dh<br>Fkt 1        | 0     | --                               | --                | --                | B                 | --                | --                | --                | --                |                      |
| Internal<br>USB 1.1<br>Controller  | Dev 1Dh<br>Fkt 2        | 0     | --                               | --                | C                 | --                | --                | --                | --                | --                |                      |
| Internal<br>USB 2.0<br>Controller  | Dev 1Dh<br>Fkt 7        | 0     | --                               | --                | --                | --                | --                | --                | --                | D                 |                      |
| IDE<br>(native<br>mode<br>only)    | Dev 1Fh<br>Fkt 1        | 0     | --                               | --                | A                 | --                | --                | --                | --                | --                |                      |
| SMBus                              | Dev 1Fh<br>Fkt 3        | 0     | --                               | B                 | --                | --                | --                | --                | --                | --                |                      |
| AC97<br>Sound                      | Dev 1Fh<br>Fkt 5        | 0     | --                               | B                 | --                | --                | --                | --                | --                | --                |                      |
| AC97<br>Modem                      | Dev 1Fh<br>Fkt 6        | 0     | --                               | B                 | --                | --                | --                | --                | --                | --                |                      |

### 2.6.3 PCI bus master signal assignment

| PCI signal | Slot1     | Slot2     | Slot3     | Slot4     |
|------------|-----------|-----------|-----------|-----------|
| REQ#       | PCI_REQ0# | PCI_REQ1# | PCI_REQ2# | PCI_REQ3# |
| GNT#       | PCI_GNT0# | PCI_GNT1# | PCI_GNT2# | PCI_GNT3# |

All REQ#/GNT# pairs are available for external PCI bus masters.

### 2.6.4 SMBus address map

| Device                        | A6 | A5 | A4 | A3 | A2 | A1 | A0 | R/W | address *) |
|-------------------------------|----|----|----|----|----|----|----|-----|------------|
| core temperature (MAX1618)    | 0  | 1  | 0  | 1  | 0  | 1  | 0  | x   | 54h / 2Ah  |
| hardware monitor (W83L786R)   | 0  | 1  | 0  | 1  | 1  | 1  | 1  | x   | 5Eh / 2Fh  |
| clock synthesizer (ICS950810) | 1  | 1  | 0  | 1  | 0  | 0  | 1  | x   | D2h / 69h  |
| watchdog (PIC12C509)          | 1  | 0  | 1  | 1  | 0  | 0  | 0  | x   | B0h / 58h  |
| CMOS backup EEPROM #1         | 1  | 0  | 1  | 0  | 1  | 0  | 0  | x   | A8h / 54h  |
| CMOS backup EEPROM #2         | 1  | 0  | 1  | 0  | 1  | 0  | 1  | x   | AAh / 55h  |
| SPD EEPROM (SO-DIMM)          | 1  | 0  | 1  | 0  | 0  | 0  | 0  | x   | A0h / 50h  |

\*) 8 bit address (with R/W) / 7 bit address (without R/W)

### 3 Mechanical Specification

#### 3.1 Top view

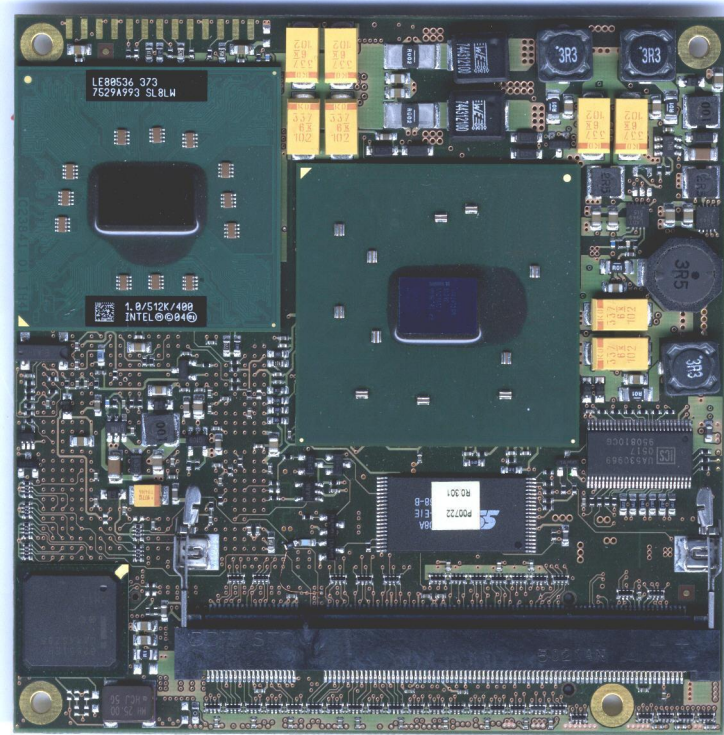

#### 3.2 Bottom view

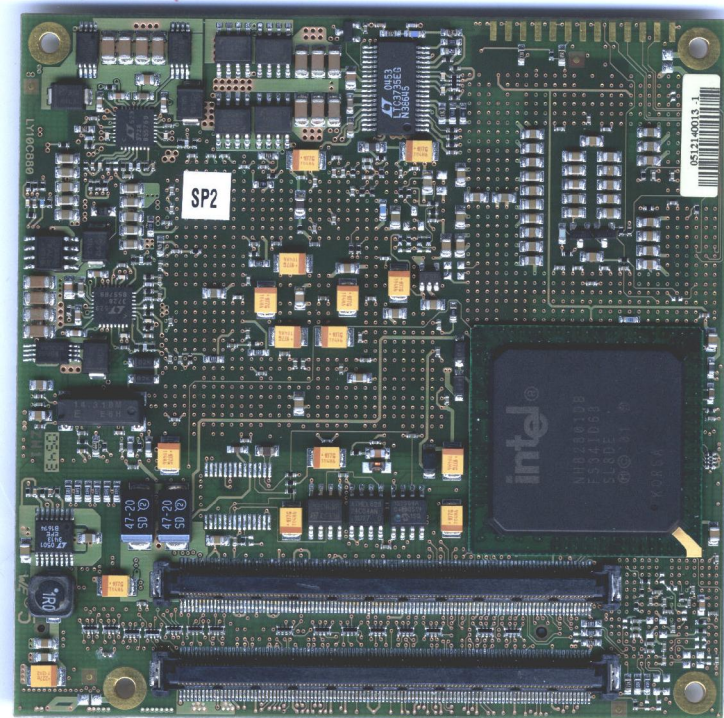

### 3.3 Mechanical drawing

The module is a „Compact Module“ Type 2, 95 x 95 mm

Height: max. 8 mm on top side  
 max. 3,8 mm on bottom side

PCB: 1,8 mm

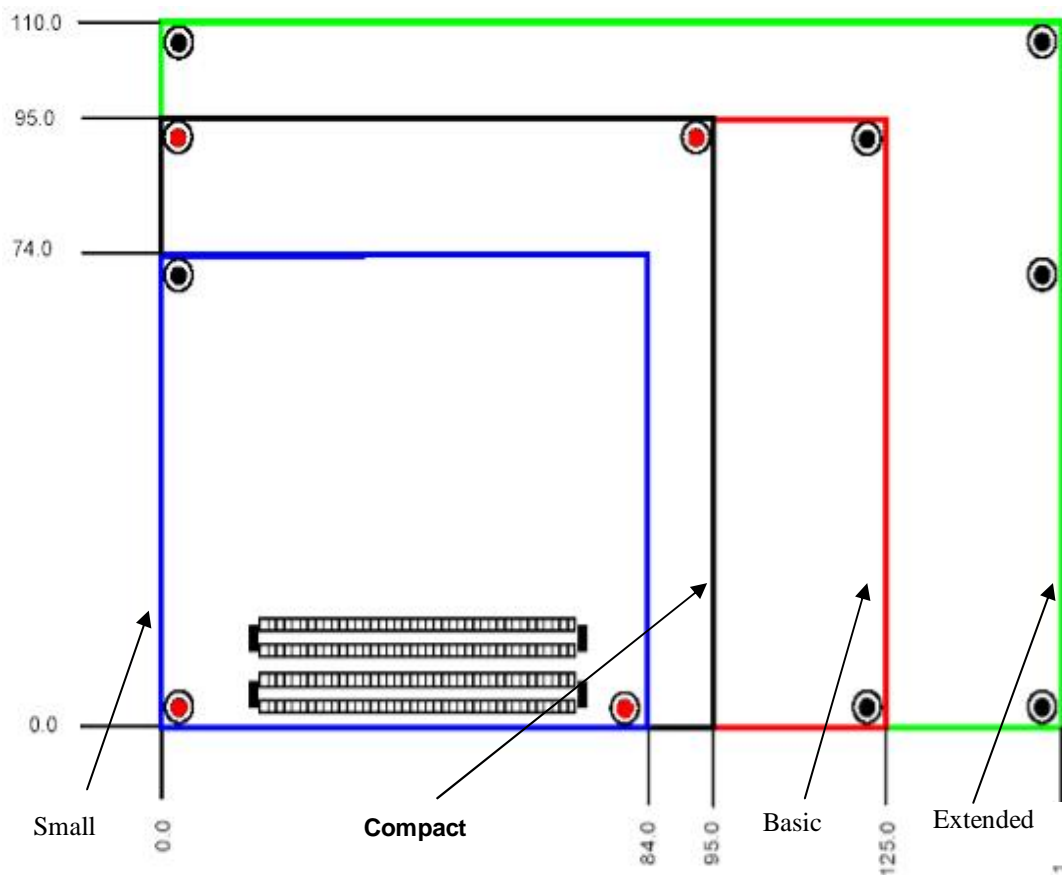
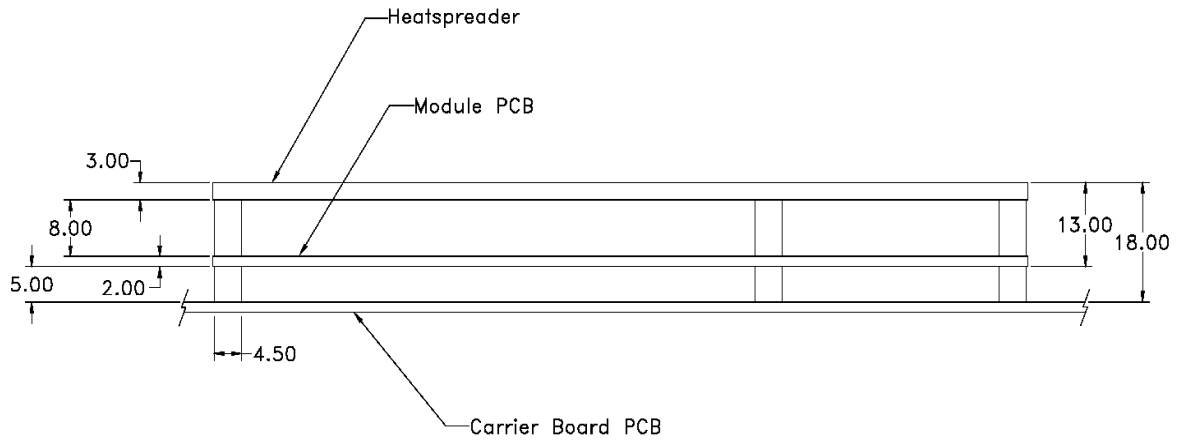

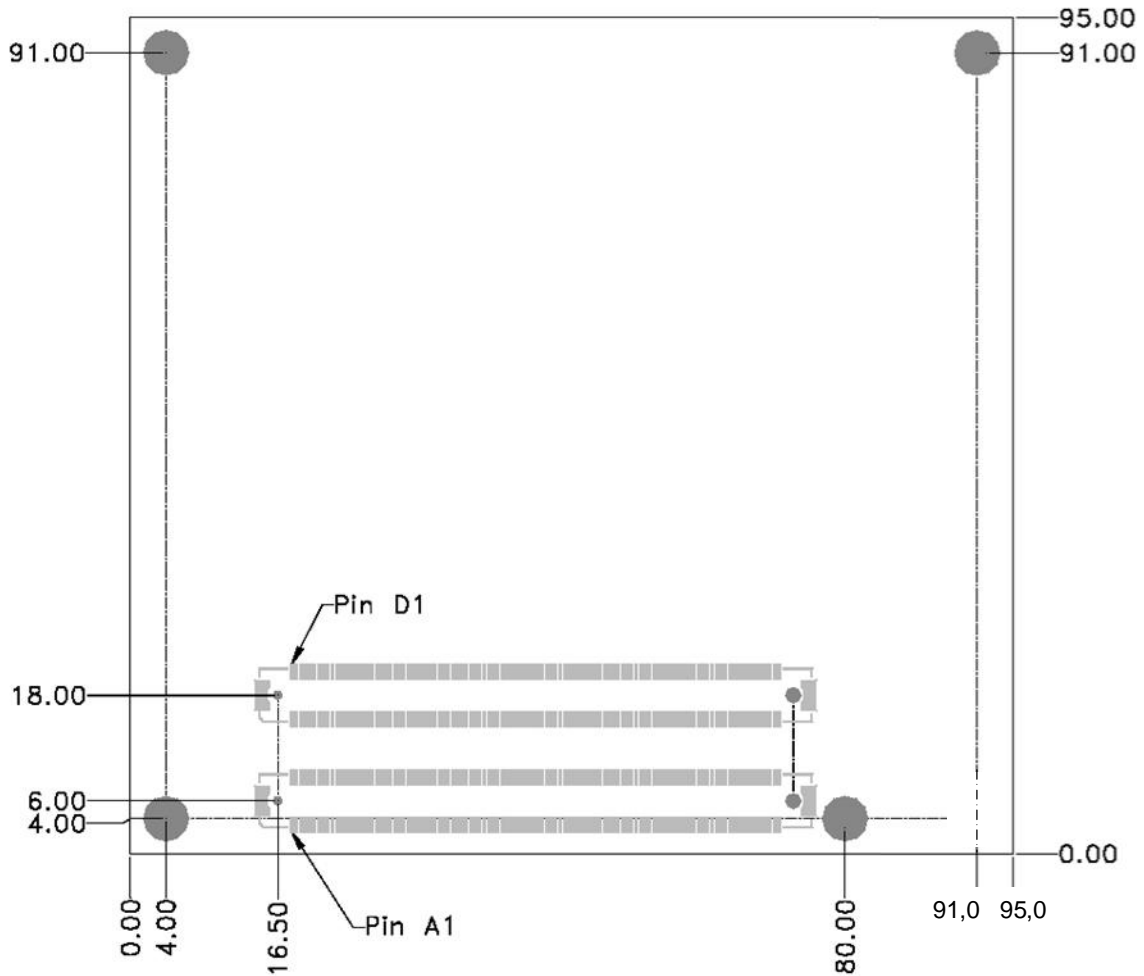

The 4 mounting holes shown shall use 6mm diameter pads and shall have 2.7mm plated holes, for use with 2.5mm hardware. The pads shall be tied to the PCB ground plane.

### 3.3.1 Heat spreader options

- Heat spreader with through hole standoffs (3mm)
- Heat spreader with threaded corner standoffs (2,5mm)

## 4 Cooling concept

The cooling solution of a COM Express module is based on a heatspreader concept.

A heatspreader is a metal plate (typically aluminium) mounted on the top of the module. The connection between this plate and the module components is typically done by thermal interface materials like phase change foils, gap pads and copper or aluminium blocks. A very good thermal conductivity is required in order to conduct the heat from the cpu and the chipset to the heatspreader plate.

The heatspreader of the MSC module is thermally attached using phase change materials and small aluminium blocks filling the gap between cpu and chipset dies and the heatspreader plate.

### The heatspreader is not a heatsink!

The heatspreader is a defined thermal interface for the system designer with fixed mechanical dimensions, so it should be possible to change different module types without problems. There must be a cooling solution for the system, the surface temperature of the heatspreader should not exceed 60°C .

Main issue for the thermal functionality of a system is that each device of the module is operated within its specified thermal values. The max values of cpu and chipset are 100°C, so there may be system implementations where the heatspreader temperature could be higher.

But there are other chips on the module and it has to be validated that there are no thermal spec violations for these devices over the system temperature range.

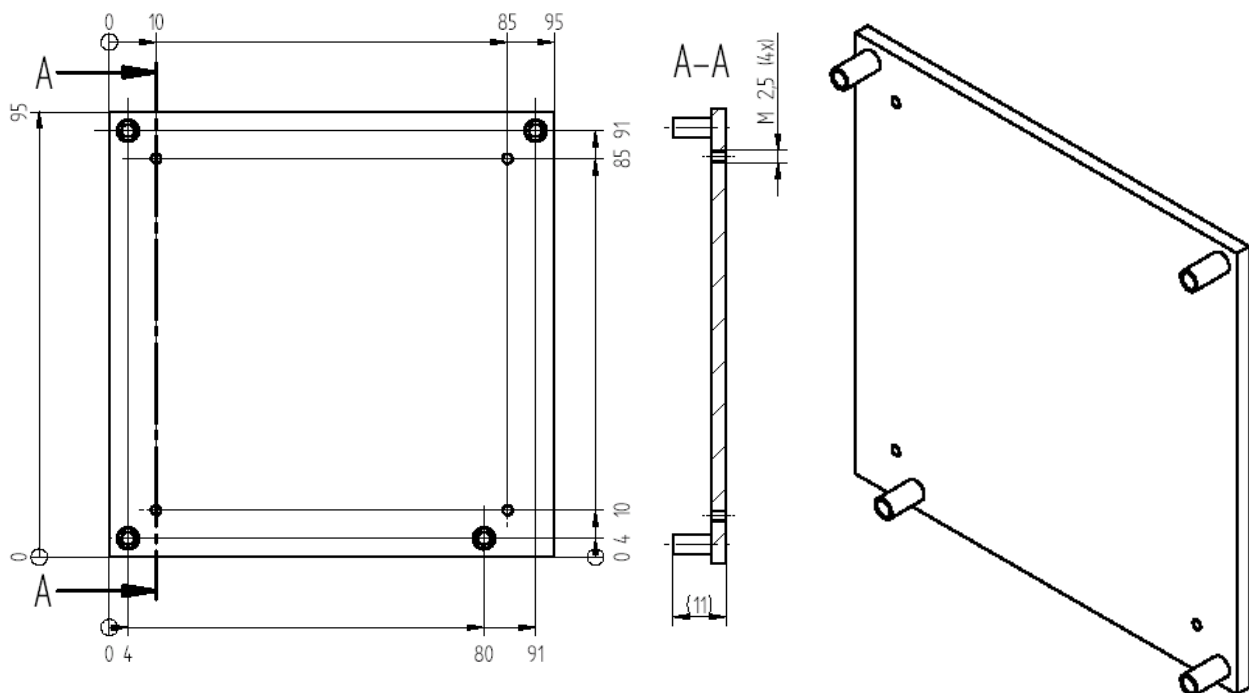

## 5 COM Express Connectors

### **Differences to COM Express Specification:**

The module differs from the current COM Express specification.

Yellow marked functions are not available.

## 5.1 Rows A and B

| RowA |                | Remark | RowB |            | Remark                  |
|------|----------------|--------|------|------------|-------------------------|
| A1   | GND(FIXED)     |        | B1   | GND(FIXED) |                         |
| A2   | GBE0_MDI3-     |        | B2   | GBE0_ACT#  |                         |
| A3   | GBE0_MDI3+     |        | B3   | LPC_FRAME# |                         |
| A4   | GBE0_LINK100#  |        | B4   | LPC_AD0    |                         |
| A5   | GBE0_LINK1000# |        | B5   | LPC_AD1    |                         |
| A6   | GBE0_MDI2-     |        | B6   | LPC_AD2    |                         |
| A7   | GBE0_MDI2+     |        | B7   | LPC_AD3    |                         |
| A8   | GBE0_LINK#     |        | B8   | LPC_DRQ0#  |                         |
| A9   | GBE0_MDI1-     |        | B9   | LPC_DRQ1#  |                         |
| A10  | GBE0_MDI1+     |        | B10  | LPC_CLK    |                         |
| A11  | GND(FIXED)     |        | B11  | GND(FIXED) |                         |
| A12  | GBE0_MDI0-     |        | B12  | PWRBTN#    | Pu 8,2k to 3,3V Standby |
| A13  | GBE0_MDI0+     |        | B13  | SMB_CK     | Pu 4,7k to +3,3V        |
| A14  | GBE0_CTREF     |        | B14  | SMB_DAT    | Pu 4,7k to +3,3V        |
| A15  | SUS_S3#        |        | B15  | SMB_ALERT# | Pu 10k to 3,3V Standby  |
| A16  | SATA0_TX+      |        | B16  | SATA1_TX+  |                         |
| A17  | SATA0_TX-      |        | B17  | SATA1_TX-  |                         |
| A18  | SUS_S4#        |        | B18  | SUS_STAT#  |                         |
| A19  | SATA0_RX+      |        | B19  | SATA1_RX+  |                         |
| A20  | SATA0_RX-      |        | B20  | SATA1_RX-  |                         |
| A21  | GND(FIXED)     |        | B21  | GND(FIXED) |                         |
| A22  | SATA2_TX+      |        | B22  | SATA3_TX+  |                         |
| A23  | SATA2_TX-      |        | B23  | SATA3_TX-  |                         |
| A24  | SUS_S5#        |        | B24  | PWR_OK     | +3,3V for power on      |
| A25  | SATA2_RX+      |        | B25  | SATA3_RX+  |                         |
| A26  | SATA2_RX-      |        | B26  | SATA3_RX-  |                         |
| A27  | BATLOW#        |        | B27  | WDT        | +5V signal              |
| A28  | ATA_ACT#       |        | B28  | AC_SDIN2   |                         |
| A29  | AC_SYNC        |        | B29  | AC_SDIN1   |                         |
| A30  | AC_RST#        |        | B30  | AC_SDIN0   |                         |
| A31  | GND(FIXED)     |        | B31  | GND(FIXED) |                         |
| A32  | AC_BITCLK      |        | B32  | SPKR       |                         |

|     |               |                         |     |             |                         |
|-----|---------------|-------------------------|-----|-------------|-------------------------|
| A33 | AC_SDOOUT     |                         | B33 | I2C_CK      | Pu 4,7k to +3,3V        |
| A34 | BIOS_DISABLE# | Pu 330R to +3,3V        | B34 | I2C_DAT     | Pu 4,7k to +3,3V        |
| A35 | THRMTRIP#     |                         | B35 | THRM#       |                         |
| A36 | USB6-         |                         | B36 | USB7-       |                         |
| A37 | USB6+         |                         | B37 | USB7+       |                         |
| A38 | USB_6_7_OC#   |                         | B38 | USB_4_5_OC# | Pu 8,2k to 3,3V Standby |
| A39 | USB4-         |                         | B39 | USB5-       |                         |
| A40 | USB4+         |                         | B40 | USB5+       |                         |
| A41 | GND(FIXED)    |                         | B41 | GND(FIXED)  |                         |
| A42 | USB2-         |                         | B42 | USB3-       |                         |
| A43 | USB2+         |                         | B43 | USB3+       |                         |
| A44 | USB_2_3_OC#   | Pu 8,2k to 3,3V Standby | B44 | USB_0_1_OC# | Pu 8,2k to 3,3V Standby |
| A45 | USB0-         |                         | B45 | USB1-       |                         |
| A46 | USB0+         |                         | B46 | USB1+       |                         |
| A47 | VCC_RTC       |                         | B47 | EXCD1_RST#  |                         |
| A48 | EXCD0_RST#    |                         | B48 | EXCD1_CPPE# |                         |
| A49 | EXCD0_CPPE#   |                         | B49 | SYS_RESET#  | Pu 4,7K to +3,3V        |
| A50 | LPC_SERIRQ    | Pu 10k to +3,3V         | B50 | CB_RESET#   |                         |
| A51 | GND(FIXED)    |                         | B51 | GND(FIXED)  |                         |
| A52 | PCIE_TX5+     |                         | B52 | PCIE_RX5+   |                         |
| A53 | PCIE_TX5-     |                         | B53 | PCIE_RX5-   |                         |
| A54 | GPI0          | 3,3V signal             | B54 | GPO1        | 3,3V signal             |
| A55 | PCIE_TX4+     |                         | B55 | PCIE_RX4+   |                         |
| A56 | PCIE_TX4-     |                         | B56 | PCIE_RX4-   |                         |
| A57 | GND           |                         | B57 | GPO2        | 3,3V signal             |
| A58 | PCIE_TX3+     |                         | B58 | PCIE_RX3+   |                         |
| A59 | PCIE_TX3-     |                         | B59 | PCIE_RX3-   |                         |
| A60 | GND(FIXED)    |                         | B60 | GND(FIXED)  |                         |
| A61 | PCIE_TX2+     |                         | B61 | PCIE_RX2+   |                         |
| A62 | PCIE_TX2-     |                         | B62 | PCIE_RX2-   |                         |
| A63 | GPI1          | 3,3V signal             | B63 | GPO3        | 3,3V signal             |
| A64 | PCIE_TX1+     |                         | B64 | PCIE_RX1+   |                         |
| A65 | PCIE_TX1-     |                         | B65 | PCIE_RX1-   |                         |
| A66 | GND           |                         | B66 | WAKE0#      |                         |

|      |               |                              |      |                    |  |
|------|---------------|------------------------------|------|--------------------|--|
| A67  | GPI2          | 3,3V signal                  | B67  | WAKE1#             |  |
| A68  | PCIE_TX0+     |                              | B68  | PCIE_RX0+          |  |
| A69  | PCIE_TX0-     |                              | B69  | PCIE_RX0-          |  |
| A70  | GND(FIXED)    |                              | B70  | GND(FIXED)         |  |
| A71  | LVDS_A0+      |                              | B71  | LVDS_B0+           |  |
| A72  | LVDS_A0-      |                              | B72  | LVDS_B0-           |  |
| A73  | LVDS_A1+      |                              | B73  | LVDS_B1+           |  |
| A74  | LVDS_A1-      |                              | B74  | LVDS_B1-           |  |
| A75  | LVDS_A2+      |                              | B75  | LVDS_B2+           |  |
| A76  | LVDS_A2-      |                              | B76  | LVDS_B2-           |  |
| A77  | LVDS_VDD_EN   |                              | B77  | LVDS_B3+           |  |
| A78  | LVDS_A3+      |                              | B78  | LVDS_B3-           |  |
| A79  | LVDS_A3-      |                              | B79  | LVDS_BKLT_EN       |  |
| A80  | GND(FIXED)    |                              | B80  | GND(FIXED)         |  |
| A81  | LVDS_A_CK+    |                              | B81  | LVDS_B_CK+         |  |
| A82  | LVDS_A_CK-    |                              | B82  | LVDS_B_CK-         |  |
| A83  | LVDS_I2C_CK   | Requires Pu<br>4,7k to +3,3V | B83  | LVDS_BKLT_C<br>TRL |  |
| A84  | LVDS_I2C_DAT  | Requires Pu<br>4,7k to +3,3V | B84  | VCC_5V_SBY         | Not required if<br>standby not<br>used |
| A85  | GPI3          | 3,3V signal                  | B85  | VCC_5V_SBY         |  |
| A86  | KBD_RST#      |                              | B86  | VCC_5V_SBY         |  |
| A87  | KBD_A20GATE   |                              | B87  | VCC_5V_SBY         |  |
| A88  | PCIE0_CK_REF+ |                              | B88  | RSVD               |  |
| A89  | PCIE0_CK_REF- |                              | B89  | VGA_RED            |  |
| A90  | GND(FIXED)    |                              | B90  | GND(FIXED)         |  |
| A91  | RSVD          |                              | B91  | VGA_GRN            |  |
| A92  | RSVD          |                              | B92  | VGA_BLU            |  |
| A93  | GPO0          | 3,3V signal                  | B93  | VGA_HSYNC          |  |
| A94  | RSVD          |                              | B94  | VGA_VSYNC          |  |
| A95  | RSVD          |                              | B95  | VGA_I2C_CK         | Requires Pu<br>4,7k to +3,3V           |
| A96  | GND           |                              | B96  | VGA_I2C_DAT        | Requires Pu<br>4,7k to +3,3V           |
| A97  | VCC_12V       |                              | B97  | TV_DAC_A           |  |
| A98  | VCC_12V       |                              | B98  | TV_DAC_B           |  |
| A99  | VCC_12V       |                              | B99  | TV_DAC_C           |  |
| A100 | GND(FIXED)    |                              | B100 | GND(FIXED)         |  |
| A101 | VCC_12V       |                              | B101 | VCC_12V            |  |

|      |            |  |      |            |  |
|------|------------|--|------|------------|--|
| A102 | VCC_12V    |  | B102 | VCC_12V    |  |
| A103 | VCC_12V    |  | B103 | VCC_12V    |  |
| A104 | VCC_12V    |  | B104 | VCC_12V    |  |
| A105 | VCC_12V    |  | B105 | VCC_12V    |  |
| A106 | VCC_12V    |  | B106 | VCC_12V    |  |
| A107 | VCC_12V    |  | B107 | VCC_12V    |  |
| A108 | VCC_12V    |  | B108 | VCC_12V    |  |
| A109 | VCC_12V    |  | B109 | VCC_12V    |  |
| A110 | GND(FIXED) |  | B110 | GND(FIXED) |  |

## 5.2 Rows C and D

| RowC |             | Remark | RowD |            | Remark |
|------|-------------|--------|------|------------|--------|
| C1   | GND(FIXED)  |        | D1   | GND(FIXED) |        |
| C2   | IDE_D7      |        | D2   | IDE_D5     |        |
| C3   | IDE_D6      |        | D3   | IDE_D10    |        |
| C4   | IDE_D3      |        | D4   | IDE_D11    |        |
| C5   | IDE_D15     |        | D5   | IDE_D12    |        |
| C6   | IDE_D8      |        | D6   | IDE_D4     |        |
| C7   | IDE_D9      |        | D7   | IDE_D0     |        |
| C8   | IDE_D2      |        | D8   | IDE_REQ    |        |
| C9   | IDE_D13     |        | D9   | IDE_IOW#   |        |
| C10  | IDE_D1      |        | D10  | IDE_ACK#   |        |
| C11  | GND(FIXED)  |        | D11  | GND(FIXED) |        |
| C12  | IDE_D14     |        | D12  | IDE_IRQ    |        |
| C13  | IDE_IORDY   |        | D13  | IDE_A0     |        |
| C14  | IDE_IOR#    |        | D14  | IDE_A1     |        |
| C15  | PCI_PME#    |        | D15  | IDE_A2     |        |
| C16  | PCI_GNT2#   |        | D16  | IDE_CS1#   |        |
| C17  | PCI_REQ2#   |        | D17  | IDE_CS3#   |        |
| C18  | PCI_GNT1#   |        | D18  | IDE_RESET# |        |
| C19  | PCI_REQ1#   |        | D19  | PCI_GNT3#  |        |
| C20  | PCI_GNT0#   |        | D20  | PCI_REQ3#  |        |
| C21  | GND(FIXED)  |        | D21  | GND(FIXED) |        |
| C22  | PCI_REQ0#   |        | D22  | PCI_AD1    |        |
| C23  | PCI_RESET#  |        | D23  | PCI_AD3    |        |
| C24  | PCI_AD0     |        | D24  | PCI_AD5    |        |
| C25  | PCI_AD2     |        | D25  | PCI_AD7    |        |
| C26  | PCI_AD4     |        | D26  | PCI_C/BE0# |        |
| C27  | PCI_AD6     |        | D27  | PCI_AD9    |        |
| C28  | PCI_AD8     |        | D28  | PCI_AD11   |        |
| C29  | PCI_AD10    |        | D29  | PCI_AD13   |        |
| C30  | PCI_AD12    |        | D30  | PCI_AD15   |        |
| C31  | GND(FIXED)  |        | D31  | GND(FIXED) |        |
| C32  | PCI_AD14    |        | D32  | PCI_PAR    |        |
| C33  | PCI_C/BE1#  |        | D33  | PCI_SERR#  |        |
| C34  | PCI_PERR#   |        | D34  | PCI_STOP#  |        |
| C35  | PCI_LOCK#   |        | D35  | PCI_TRDY#  |        |
| C36  | PCI_DEVSEL# |        | D36  | PCI_FRAME# |        |

|     |            |  |     |              |  |
|-----|------------|--|-----|--------------|--|
| C37 | PCI_IRDY#  |  | D37 | PCI_AD16     |  |
| C38 | PCI_C/BE2# |  | D38 | PCI_AD18     |  |
| C39 | PCI_AD17   |  | D39 | PCI_AD20     |  |
| C40 | PCI_AD19   |  | D40 | PCI_AD22     |  |
| C41 | GND(FIXED) |  | D41 | GND(FIXED)   |  |
| C42 | PCI_AD21   |  | D42 | PCI_AD24     |  |
| C43 | PCI_AD23   |  | D43 | PCI_AD26     |  |
| C44 | PCI_C/BE3# |  | D44 | PCI_AD28     |  |
| C45 | PCI_AD25   |  | D45 | PCI_AD30     |  |
| C46 | PCI_AD27   |  | D46 | PCI_IRQC#    |  |
| C47 | PCI_AD29   |  | D47 | PCI_IRQD#    |  |
| C48 | PCI_AD31   |  | D48 | PCI_CLKRUN#  |  |
| C49 | PCI_IRQA#  |  | D49 | PCI_M66EN    |  |
| C50 | PCI_IRQB#  |  | D50 | PCI_CLK      |  |
| C51 | GND(FIXED) |  | D51 | GND(FIXED)   |  |
| C52 | PEG_RX0+   |  | D52 | PEG_TX0+     |  |
| C53 | PEG_RX0-   |  | D53 | PEG_TX0-     |  |
| C54 | TYPE0#     |  | D54 | PEG_LANE_RV# |  |
| C55 | PEG_RX1+   |  | D55 | PEG_TX1+     |  |
| C56 | PEG_RX1-   |  | D56 | PEG_TX1-     |  |
| C57 | TYPE1#     |  | D57 | TYPE2#       |  |
| C58 | PEG_RX2+   |  | D58 | PEG_TX2+     |  |
| C59 | PEG_RX2-   |  | D59 | PEG_TX2-     |  |
| C60 | GND(FIXED) |  | D60 | GND(FIXED)   |  |
| C61 | PEG_RX3+   |  | D61 | PEG_TX3+     |  |
| C62 | PEG_RX3-   |  | D62 | PEG_TX3-     |  |
| C63 | RSVD       |  | D63 | RSVD         |  |
| C64 | RSVD       |  | D64 | RSVD         |  |
| C65 | PEG_RX4+   |  | D65 | PEG_TX4+     |  |
| C66 | PEG_RX4-   |  | D66 | PEG_TX4-     |  |
| C67 | RSVD       |  | D67 | GND          |  |
| C68 | PEG_RX5+   |  | D68 | PEG_TX5+     |  |
| C69 | PEG_RX5-   |  | D69 | PEG_TX5-     |  |
| C70 | GND(FIXED) |  | D70 | GND(FIXED)   |  |
| C71 | PEG_RX6+   |  | D71 | PEG_TX6+     |  |
| C72 | PEG_RX6-   |  | D72 | PEG_TX6-     |  |
| C73 | SDVO_DATA  |  | D73 | SDVO_CLK     |  |
| C74 | PEG_RX7+   |  | D74 | PEG_TX7+     |  |

|      |            |  |      |             |  |
|------|------------|--|------|-------------|--|
| C75  | PEG_RX7-   |  | D75  | PEG_TX7-    |  |
| C76  | GND        |  | D76  | GND         |  |
| C77  | RSVD       |  | D77  | IDE_CBLID#  |  |
| C78  | PEG_RX8+   |  | D78  | PEG_TX8+    |  |
| C79  | PEG_RX8-   |  | D79  | PEG_TX8-    |  |
| C80  | GND(FIXED) |  | D80  | GND(FIXED)  |  |
| C81  | PEG_RX9+   |  | D81  | PEG_TX9+    |  |
| C82  | PEG_RX9-   |  | D82  | PEG_TX9-    |  |
| C83  | RSVD       |  | D83  | RSVD        |  |
| C84  | GND        |  | D84  | GND         |  |
| C85  | PEG_RX10+  |  | D85  | PEG_TX10+   |  |
| C86  | PEG_RX10-  |  | D86  | PEG_TX10-   |  |
| C87  | GND        |  | D87  | GND         |  |
| C88  | PEG_RX11+  |  | D88  | PEG_TX11+   |  |
| C89  | PEG_RX11-  |  | D89  | PEG_TX11-   |  |
| C90  | GND(FIXED) |  | D90  | GND(FIXED)  |  |
| C91  | PEG_RX12+  |  | D91  | PEG_TX12+   |  |
| C92  | PEG_RX12-  |  | D92  | PEG_TX12-   |  |
| C93  | GND        |  | D93  | GND         |  |
| C94  | PEG_RX13+  |  | D94  | PEG_TX13+   |  |
| C95  | PEG_RX13-  |  | D95  | PEG_TX13-   |  |
| C96  | GND        |  | D96  | GND         |  |
| C97  | RSVD       |  | D97  | PEG_ENABLE# |  |
| C98  | PEG_RX14+  |  | D98  | PEG_TX14+   |  |
| C99  | PEG_RX14-  |  | D99  | PEG_TX14-   |  |
| C100 | GND(FIXED) |  | D100 | GND(FIXED)  |  |
| C101 | PEG_RX15+  |  | D101 | PEG_TX15+   |  |
| C102 | PEG_RX15-  |  | D102 | PEG_TX15-   |  |
| C103 | GND        |  | D103 | GND         |  |
| C104 | VCC_12V    |  | D104 | VCC_12V     |  |
| C105 | VCC_12V    |  | D105 | VCC_12V     |  |
| C106 | VCC_12V    |  | D106 | VCC_12V     |  |
| C107 | VCC_12V    |  | D107 | VCC_12V     |  |
| C108 | VCC_12V    |  | D108 | VCC_12V     |  |
| C109 | VCC_12V    |  | D109 | VCC_12V     |  |
| C110 | GND(FIXED) |  | D110 | GND(FIXED)  |  |

## 6 BIOS

### 6.1 Introduction

This guide describes the Phoenix FirstBIOS Pro Startup screen and contains information on how to access Phoenix FirstBIOS Pro setup to modify the settings which control Phoenix pre-OS (operating system) functions.

#### 6.1.1 BIOS Version

Phoenix FirstBIOS™ Pro for CXC-PM855 BIOS V1.00

#### 6.1.2 Startup Screen Overview

The Phoenix FirstBIOS Pro Startup screen is a graphical user interface (GUI) that is included in Phoenix FirstBIOS Pro products. A Startup screen consists of:

**Progress Bar:** Part of the Status Bar, it indicates the progress of the Startup Screen functions and provides user prompting and POST status

The following figure shows the various parts of a generic Startup Screen at 1024x768 resolution:

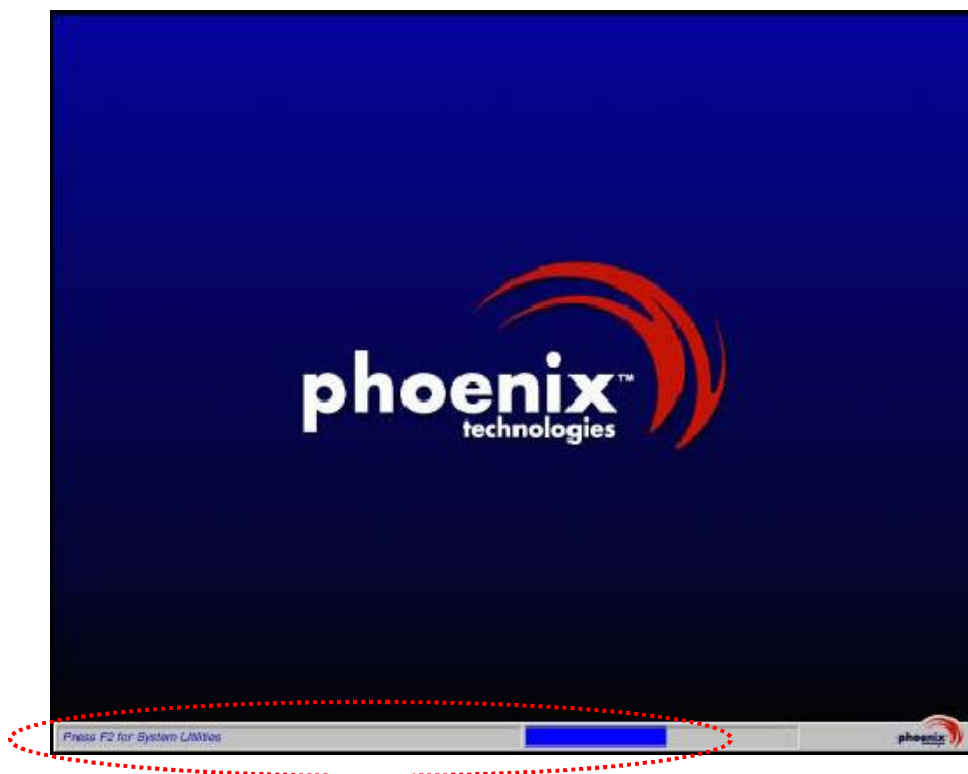

### 6.1.3 Activity Detection Background

While the FirstBIOS Startup screen is displayed, press the Setup Entry key (F2 - FirstBIOS default). The FirstBIOS Startup Status Bar acknowledges the input, and at the end of POST, the screen clears and Setup launches.

An example of the Startup Status Bar displaying changing state is shown in the following figure. The Please Wait... text is displayed after the F2 key is pressed to acknowledge user input.

Active status bar:



## 6.2 FirstBIOS Pro Setup Utility

With the Phoenix FirstBIOS Pro Setup program, you can modify FirstBIOS Pro settings and control the special features of your computer. The Setup program uses a number of menus for making changes and turning the special features on or off. This chapter provides an overview of the Setup utility and describes at a high-level how to use it.

### 6.2.1 The Main Menu

To start the Phoenix FirstBIOS Pro Setup utility, press [F2] to launch Setup. The Setup main menu displays.

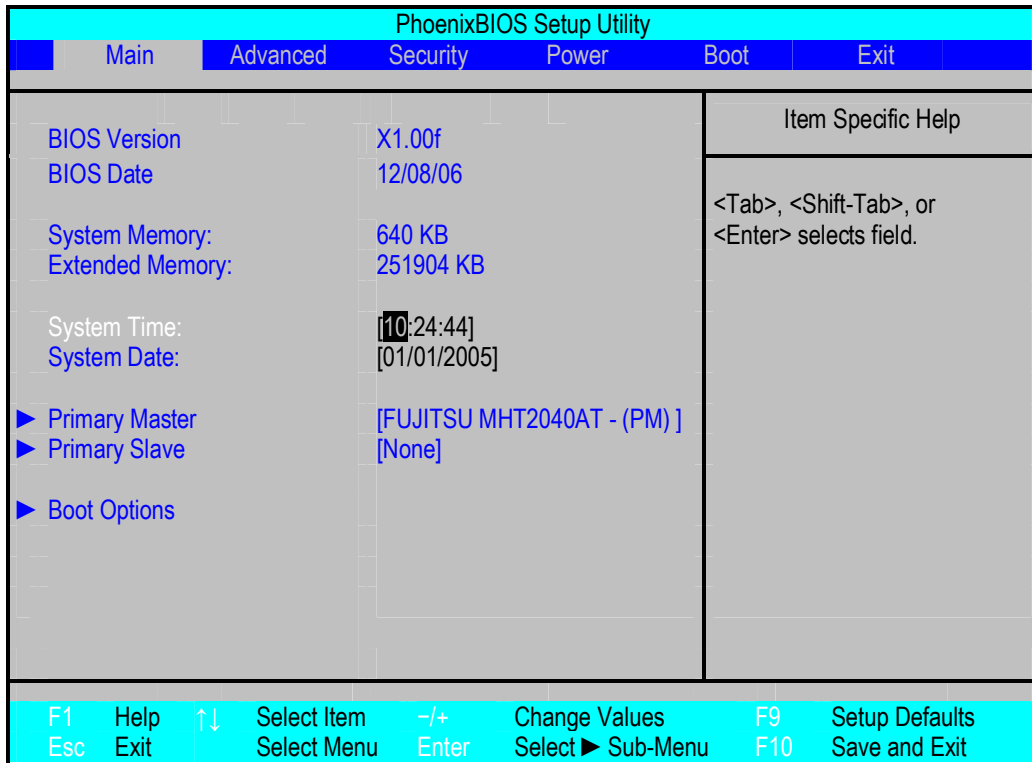

#### The Menu Bar

The Menu Bar at the top of the window lists these selections:

| Menu Items | Description  |
|------------|--|
| Main       | Use this menu for basic system configuration.  |
| Advanced   | Use this menu to set the Advanced Features available on your system's chipset.               |
| Security   | Use this menu to set User and Supervisor Passwords and the Backup and Virus-Check reminders. |
| Power      | Use this menu to configure Power-Management features.  |
| Boot       | Use this menu to set the boot order in which the BIOS attempts to boot to OS.                |

|      |                         |
|------|-------------------------|
| Exit | Exits the current menu. |
|------|-------------------------|

Use the left and right arrow keys on your keyboard to make a menu selection.

### The Legend Bar

Use the keys listed in the legend bar on the bottom of the screen to make your selections, or to exit the current menu. The following table describes the legend keys and their alternates:

| Key                    | Function   |
|------------------------|--|
| F1 or Alt-H            | General Help window.                                   |
| Esc                    | Exit this menu.  |
| Arrow keys             | Select a different menu.                               |
| Up and down arrow keys | Move cursor up and down.                               |
| Tab or Shift-Tab       | Cycle cursor up and down.                              |
| Home or End            | Move cursor to top or bottom of window.                |
| PgUp or PgDn           | Move cursor to next or previous page.                  |
| F5 or -                | Select the previous value for the field.               |
| F6 or + or Space       | Select the next value for the field.                   |
| F9                     | Load the Default Configuration values (for all menus). |
| F10                    | Save and exit.   |
| Enter                  | Execute command or select submenu.                     |
| Alt-R                  | Refresh screen.  |

**To select an item**, use the arrow keys to move the cursor to the field you want. Then use the plus-and-minus value keys to select a value for that field. The Save Values commands in the Exit Menu save the values currently displayed in all the menus.

**To display a submenu**, use the arrow keys to move the cursor to the sub menu you want. Then press Enter. A pointer marks all submenus.

### 6.2.1.1 Main Menu Selections

You can make the following selections on the Main Menu itself. Use the sub menus for other selections.

| Feature         | Options                           | Description   |
|-----------------|-----------------------------------|---|
| BIOS Version    | N/A                               | Displays the version of the BIOS.                               |
| BIOS Date       | N/A                               | Displays the date of the BIOS.                                  |
| System Memory   | N/A                               | Displays amount of conventional memory detected during boot up. |
| Extended Memory | N/A                               | Displays amount of extended memory detected during boot up.     |
| System Time     | HH:MM:SS                          | Set the System Time.  |
| System Date     | DD/MM/YYYY                        | Set the System Date.  |
| Primary Master  | See "Masters and Slaves" section. |   |
| Primary Slave   | See "Masters and Slaves" section. |   |
| Boot Options    | See "Boot Option" section.        |   |

### 6.2.1.2 Masters and Slaves

The **Master** and **Slave** settings on the Main Menu control these types of devices:

- **Hard-disk drives**
- **Removable-disk drives**
- **CD-ROM drives**

There is one IDE connector on your motherboard, usually labeled "Primary IDE". There are usually two connectors on each ribbon cable attached to IDE connector. When you have connected two drives to this connector, the one on the end of the cable is the Master.

When you enter Setup, the Main Menu displays the results of **Autotyping**—information each drive provides about its own size and other characteristics—and how they are arranged as Masters or Slaves on your machine.

**Note:** Do not attempt to change these settings unless you have an installed drive that does not autotype properly (such as an older hard-disk drive that does not support autotyping).

If you need to change your drive settings, select one of the Master or Slave drives on the Main Menu. This will display a menu like this:

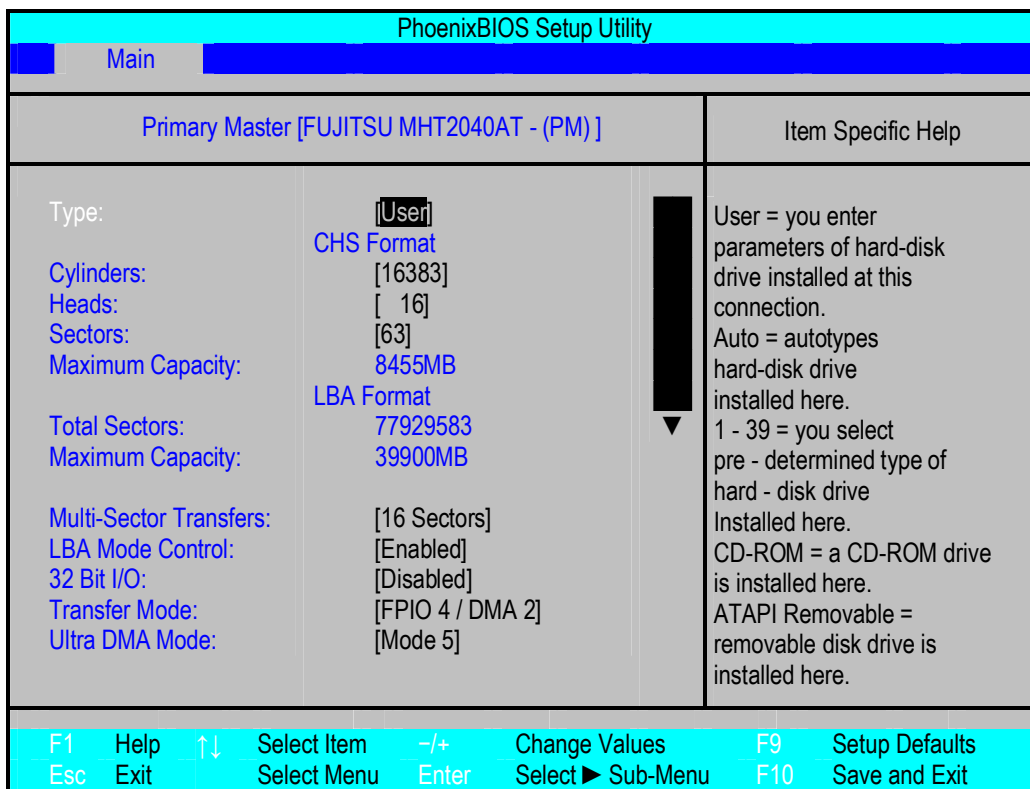

**Note:** The capacity is displayed in 'real' Mbytes (1MB=1024\*1024 Bytes) Drives with a total capacity greater than 8Gbyte operate in LBA format only.

Use the following chart to configure the hard disk drive with Advanced Hard Disk Features:

| Feature                | Options  | Description  |
|------------------------|--|--|
| Type                   | None,<br>Auto,<br>User,<br>IDE Removable,<br>ATAPI Removable,<br>Other ATAPI,<br>CD-ROM              | <b>None</b> = Autotyping is not able to supply the drive type or end user has selected None, disabling any drive that may be installed.<br><b>Auto</b> = Autotyping, the drive itself supplies the information.<br><b>User</b> = You supply the hard-disk drive information in the following fields.<br><b>IDE Removable</b> = Removable Disk Drive<br><b>ATAPI Removable</b> = Removable Disk Drive.<br><b>Other ATAPI</b> = TBD<br><b>CD-ROM</b> = CD-ROM drive. |
| Cylinders              | 1 to 65536   | Number of Cylinders  |
| Heads                  | 1 to 16  | Number of read/write heads   |
| Sectors                | 1 to 63  | Number of sectors per track  |
| Multi-Sector Transfers | Disabled, 2 sectors,<br>4 sectors, 8 sectors,<br>16 sectors  | Any selection except Disabled determines the number of sectors transferred per block.  |
| LBA Mode Control       | Disabled, Enabled  | Enabling LBA causes Logical Block Addressing to be used in place of Cylinders, Heads, & Sectors.   |
| 32 Bit I/O             | Disabled, Enabled  | Enables 32-bit communication between CPU and IDE card.Requires PCI or local bus.   |
| Transfer Mode          | Standard<br>Fast PIO 1<br>Fast PIO 2<br>Fast PIO 3<br>Fast PIO 4<br>FPIO 3 / DMA 1<br>FPIO 4 / DMA 2 | Selects the method for transferring the data between the hard disk and system memory.<br>The Setup menu only lists those options supported by the drive and platform.  |
| Ultra DMA Mode         | Disabled<br>Mode 0<br>Mode 1<br>Mode 2<br>Mode 3<br>Mode 4<br>Mode 5                                 | Ultra DMA Mode supports 33/66/100 MB/sec transfer rate for fixed disk drives.  |
| SMART Monitoring       | Disabled, Enabled  | Displays the status of SMART Monitoring if supported by the used   |

|  |  |        |
|--|--|--------|
|  |  | drive. |
|--|--|--------|

**WARNING:** Incorrect settings can cause your system to malfunction.

### 6.2.1.3 Boot Options

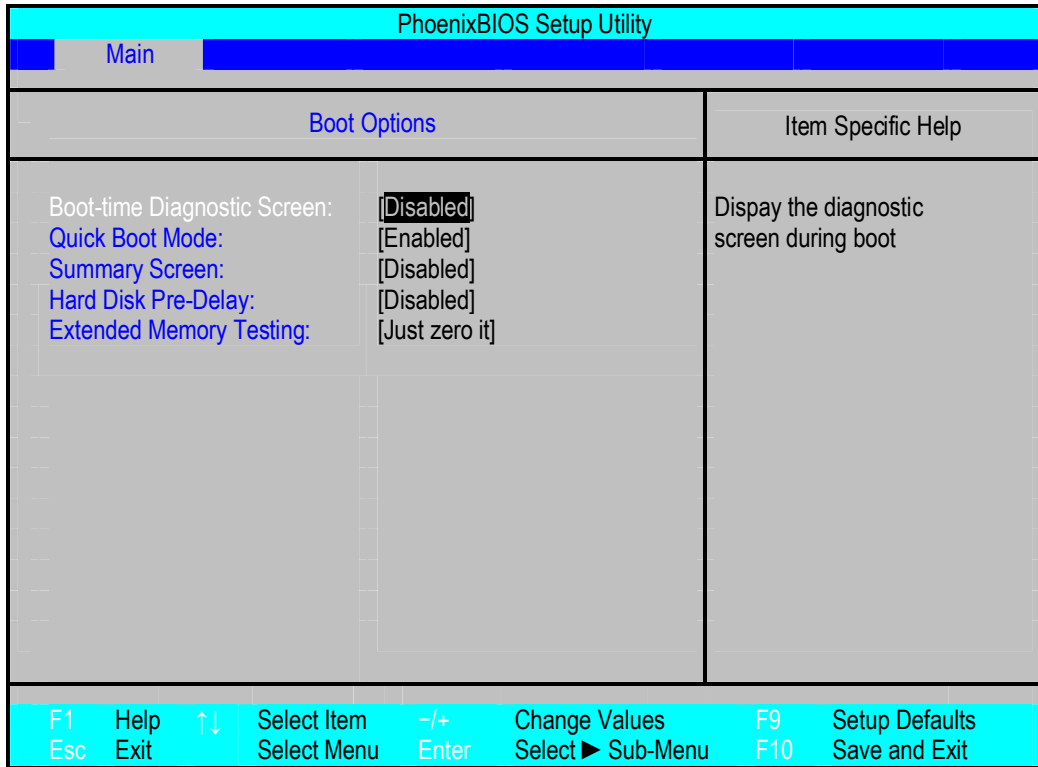

| Feature                     | Options   | Description  |
|-----------------------------|---|--|
| Boot-time Diagnostic Screen | Disabled, Enabled   | <b>Enabled</b> displays the diagnostic screen during boot.<br><b>Disabled</b> displays the Phoenix Boot Logo.  |
| Quick Boot Mode             | Disabled, Enabled   | <b>Enabled</b> allows POST to skip certain test while booting. This will decrease the time needed to boot the system.  |
| Summary screen              | Disabled, Enabled   | <b>Enabled</b> displays system configuration on boot.  |
| Hard Disk Pre-Delay         | Disabled, 3 seconds, 6 seconds, 9 seconds, 12 seconds, 15 seconds, 21 seconds, 30 seconds | Any other setting than <b>Disabled</b> adds a delay before the first access of a hard disk by the BIOS. Some hard disks hang if accessed before they have intialized themselves. |
| Extended Memory Testing     | Normal, Just zero it, None  | Determines which type of test will be performed on extended memory during POST (above 1 MB).   |

## 6.2.2 The Advanced Menu

### 6.2.2.1 Advanced Menu Selections

You can make the following selections on the Main Menu itself. Use the sub menus for other selections.

| PhoenixBIOS Setup Utility   |              |   |       |      |      |
|---|--------------|---|-------|------|------|
| Main  | Advanced     | Security  | Power | Boot | Exit |
| Installed O/S:  | [WinXP]      | Item Specific Help  |       |      |      |
| Large Disk Access Mode:   | [DOS]        | Select the operating system installed on your system which you will use most commonly.<br><br>Note: An incorrect setting can cause some operating systems to display unexpected behavior. |       |      |      |
| Small LBA-Disk CHS Translation:   | [No]         |   |       |      |      |
| <ul style="list-style-type: none"> <li>▶ PCI Configuration</li> <li>▶ I/O Device Configuration</li> <li>▶ Advanced Chipset Control</li> <li>▶ Video (Intel IGD) Control Sub-Menu</li> <li>▶ Cache Memory</li> </ul> |              |   |       |      |      |
| FirstWare Video Mode  | [1024x768]   |   |       |      |      |
| Watchdog delay:   | [30 seconds] |   |       |      |      |
| Watchdog timeout:   | [30 seconds] |   |       |      |      |
| Watchdog start on boot:   | [No]         |   |       |      |      |
| F1 Help ↑↓ Select Item -/+ Change Values F9 Setup Defaults<br>Esc Exit Select Menu Enter Select ▶ Sub-Menu F10 Save and Exit  |              |   |       |      |      |

| Feature                        | Options                             | Description   |
|--------------------------------|-------------------------------------|---|
| Installed O/S                  | Other, Win98, WinMe, Win2000, WinXP | Select the operating system installed on your system which you will use most commonly.<br><br><b>NOTE:</b> An incorrect setting can cause some operating systems to display unexpected behaviour.                         |
| Large Disk Access Mode         | Other, DOS                          | Select <b>Other</b> for UNIX, Novell NetWare. Select <b>DOS</b> for all other operating systems.  |
| Small LBA-Disk CHS Translation | No, Yes                             | Select <b>Yes</b> if CHS translation should be made for an LBA-capable hard disk with less than 1024 cylinders, e.g. Compact Flash.<br>If you have problems with booting from a Compact Flash try to change this setting. |
| FirstWare Video Mode           | 640x480, 800x600, 1024x768,         | Select the resolution to be used for the graphical boots screen.  |

|                                    |   |  |
|------------------------------------|---|--|
|                                    | 1280x1024   |  |
| Watchdog delay                     | 1, 5, 10, 30 seconds,<br>1, 5, 10, 30 minutes     | Select the time the watchdog shall wait before counting the timeout period.  |
| Watchdog timeout                   | 0.4, 1, 5, 10, 30 seconds<br>1, 5, 10 minutes     | Select the watchdog timeout which will be set at the end of POST. If watchdog will not be reloaded during the selected time, a system reset will be generated. |
| Watchdog start on boot             | Yes, No   | Select if the watchdog should be started at the end of POST – before OS is booted.   |
| I/O Device Configuration           | See “I/O Device Configuration” section.           |  |
| Advanced Chipset Control           | See “Advanced Chipset Control” section.           |  |
| Video (Intel IGD) Control Sub-Menu | See “Video (Intel IGD) Control Sub-Menu” section. |  |
| Cache Memory                       | See “Cache Memory” section.                       |  |
| PCI Configuration                  | See “PCI Configuration” section.                  |  |

### 6.2.2.2 I/O Device Configuration Menu

| PhoenixBIOS Setup Utility  |   |  |
|--|---|--|
| Advanced   |   |  |
| I/O Device Configuration   |   | Item Specific Help   |
| Serial port A:<br>Base I/O address:<br>Interrupt:                          | [Enabled]<br>[3F8]<br>[IRQ 4]                     | Configure serial port A using options:<br><br>[Disabled]<br>No configuration                         |
| Serial port B:<br>Mode:<br>Base I/O address:<br>Interrupt:                 | [Enabled]<br>[Normal]<br>[2F8]<br>[IRQ 3]         | [Enabled]<br>User configuration  |
| Parallel Port:<br>Mode:<br>Base I/O address:<br>Interrupt:<br>DMA channel: | [Enabled]<br>[ECP]<br>[378]<br>[IRQ 7]<br>[DMA 3] | [Auto]<br>BIOS or OS chooses configuration<br><br>(OS Controlled)<br>Displayed when controlled by OS |
| F1 Help ↑↓<br>Esc Exit   | Select Item -/+<br>Select Menu Enter              | Change Values F9<br>Select ► Sub-Menu F10<br>Setup Defaults<br>Save and Exit                         |

| Feature          | Options                               | Description  |
|------------------|---------------------------------------|--|
| Serial Port A    | Disabled, Enabled, Auto               | <b>Disabled</b> = Disabled the device<br><b>Enabled</b> = User configuration<br><b>Auto</b> = BIOS or OS chooses configuration |
| Base I/O address | 3F8, 2F8, 3E8, 2E8                    | Set the base I/O address for Serial Port A.  |
| Interrupt        | 3, 4                                  | Set the interrupt for Serial Port A.   |
| Serial Port B    | Disabled, Enabled, Auto               | <b>Disabled</b> = Disabled the device<br><b>Enabled</b> = User configuration<br><b>Auto</b> = BIOS or OS chooses configuration |
| Mode             | Normal, IR, ASK-IR                    | Set the mode for Serial Port B (wired / infrared).   |
| Base I/O address | 3F8, 2F8, 3E8, 2E8                    | Set the base I/O address for Serial Port B.  |
| Interrupt        | 3, 4                                  | Set the interrupt for Serial Port B.   |
| Parallel Port    | Disabled, Enabled, Auto               | <b>Disabled</b> = Disabled the device<br><b>Enabled</b> = User configuration<br><b>Auto</b> = BIOS or OS chooses configuration |
| Mode             | Output only, Bi-directional, EPP, ECP | Set the mode for Parallel Port.  |

|                  |               |  |
|------------------|---------------|--|
| Base I/O address | 378, 278, 3BC | Set the base I/O address for Parallel Port.                                    |
| Interrupt        | 5, 7          | Set the interrupt for Parallel Port.   |
| DMA channel      | 1, 3          | Set the DMA channel for Parallel Port (only available if mode was set to ECP). |

\* Indicates a DMA, Interrupt, I/O, or memory resource conflict with another device.

**Warning:** If you choose the same I/O address or Interrupt for more than one port, the menu displays an asterisk (\*) at the conflicting settings. It also displays this message at the bottom of the menu:

### 6.2.2.3 Advanced Chipset Control Menu

| PhoenixBIOS Setup Utility  |              |   |
|--|--------------|---|
| Advanced   |              |   |
| Advanced Chipset Control   |              | Item Specific Help  |
| USB 1.1 controllers:   | [Enable All] | Enable or disable the USB 1.1 controllers. At least one controller will always stay enabled for USB legacy support. |
| USB 2.0 controller:  | [Enabled]    |   |
| IDE Controller:  | [Enabled]    |   |
| AC97 Audio Device:   | [Enabled]    |   |
| Onboard LAN Controller:  | [Enabled]    |   |
| LAN Boot:  | [Disabled]   |   |
| F1 Help    ↑↓ Select Item    -/+ Change Values    F9 Setup Defaults<br>Esc Exit    Select Menu    Enter Select ► Sub-Menu    F10 Save and Exit |              |   |

| Feature                | Options                | Description  |
|------------------------|------------------------|--|
| USB 1.1 controllers    | Enable One, Enable All | Enables the USB 1.1 controllers.                                       |
| USB 2.0 controller     | Disabled, Enabled      | <b>Enabled</b> = USB 2.0 support,<br><b>Disabled</b> = USB 1.1 support |
| IDE Controller         | Disabled, Enabled      | Enables the IDE Controller.  |
| AC97 Audio Device      | Disabled, Enabled      | Enables the onboard AC97 Audio Device.                                 |
| Onboard LAN Controller | Disabled, Enabled      | Enables the onboard LAN controller                                     |
| LAN Boot               | Disabled, Enabled      | Allows network boot using the onboard LAN controller.                  |

6.2.2.4 Video (Intel IGD) Control Sub-Menu

| PhoenixBIOS Setup Utility   |                 |  |
|---|-----------------|--|
| Advanced  |                 |  |
| Video (Intel IGD) Control Sub-Menu  |                 | Item Specific Help   |
| Default Primary Video Adapter:  | [AGP]           | Select 'PCI' to have a PCI video card, if installed, used for the boot display device.   |
| MDA Seek:   | [Disabled]      |  |
| IGD - Device2:  | [Enabled]       | Select 'AGP' to have the AGP video card, if installed, used for the boot display device. |
| IGD - Device2, Function 1:  | [Enabled]       |  |
| IGD - Memory Size:  | [UMA = 8MB]     |  |
| IGD - Boot Type:  | [VBIOS Default] |  |
| IGD - LCD Panel Type (LVDS):  | [1024x768 1PPC] |  |
| IGD - Panel Scaling:  | [Auto]          |  |
| <p>F1 Help    ↑↓ Select Item    -/+ Change Values    F9 Setup Defaults</p> <p>Esc Exit    Select Menu    Enter Select ► Sub-Menu    F10 Save and Exit</p> |                 |  |

| Feature                       | Options   | Description  |
|-------------------------------|---|--|
| Default Primary Video Adapter | AGP, PCI  | Select the video card which shall be used for the boot display device, if installed.   |
| MDA Seek                      | Disabled, Enabled   | Enables Seek of MDA Video adapter during boot.   |
| IGD – Device 2                | Disabled, Enabled   | Enables the internal Graphics Device.  |
| IGD – Device 2, Function 1    | Disabled, Enabled   | Enables function 1 of the internal Graphics Device (second pipe).  |
| IGD – Memory Size             | UMA = 1 MB,<br>UMA = 8 MB,<br>UMA = 16 MB,<br>UMA = 32 MB                                   | Select the amount of main memory that the internal Graphics Device will use.   |
| IGD – Boot Type               | VBIOS default,<br>CRT, LCD,<br>CRT+LCD,<br>EFP, TV,<br>CRT+EFP                              | Select the Video Device that will be activated during POST.  |
| IGD – LCD Panel Type (LVDS)   | 640x480 1 PPC,<br>800x600 1 PPC,<br>1024x768 1 PPC,<br>1280x1024 2 PPC,<br>1400x1050 2 PPC, | Select the LCD panel to be used by the internal Graphics Device.<br><br><b>Note:</b> Due to size constrains not all Panels are exactly numbered. The first |

|                     |  |  |
|---------------------|--|--|
|                     | 1400x1050 2 PPC,<br>1600x1200 2 PPC,<br>1280x768 1 PPC,<br>1600x1050 2 PPC,<br>1920x1200 2 PPC,<br>1024x768 1 PPC,<br>1024x768 1 PPC,<br>1024x768 1 PPC,<br>1280x800 1 PPC,<br>1280x600 1 PPC,<br>1024x768 1 PPC | item is Panel 1, the last one Panel 16.                                    |
| IGD – Panel Scaling | Auto,<br>Force Scaling,<br>Off   | Selects the LCD panel scaling option used by the internal Graphics Device. |

6.2.2.5 Cache Memory Control Menu

|  |                                     |
|--|-------------------------------------|
| PhoenixBIOS Setup Utility  |                                     |
| Advanced   |                                     |
| Cache Memory   | Item Specific Help                  |
| Memory Cache: [Enabled]<br>Cache System BIOS area: [Write Protect]<br>Cache Video BIOS area: [Write Protect]<br>Cache Extended Memory Area: [Write Back]<br>Cache D000 – D3FF: [Disabled]<br>Cache D400 – D7FF: [Disabled]<br>Cache D800 – DBFF: [Disabled]<br>Cache DC00 – DFFF: [Disabled] | Sets the state of the memory cache. |
| F1 Help ↑↓ Select Item -/+ Change Values F9 Setup Defaults<br>Esc Exit Select Menu Enter Select ► Sub-Menu F10 Save and Exit   |                                     |

| Feature                | Options                  | Description                          |
|------------------------|--------------------------|--------------------------------------|
| Memory Cache           | Disabled, Enabled        | Sets the state of the memory cache.  |
| Cache System BIOS area | Uncached, Write Protect  | Enables caching of system BIOS area. |
| Cache Video BIOS area  | Uncached, Write Protect  | Enables caching of video BIOS area.  |
| Cache Extended         | Uncached, Write Through, | Enables caching of system memory     |

|  |   |   |
|--|---|---|
| Memory Area  | Write Protect,<br>Write Back                                | above 1 MB.   |
| Cache D000 – D3FF<br>Cache D400 – D7FF<br>Cache D800 – DBFF<br>Cache DC00 – DFFF | Disabled,<br>Write Through,<br>Write Protect,<br>Write Back | <p><b>Disabled</b> = This block is not cached.</p> <p><b>Write Through</b> = Writes are cached and sent to main memory at once.</p> <p><b>Write Protect</b> = Writes are ignored.</p> <p><b>Write Back</b> = Writes are cached but not sent to main memory until necessary.</p> |

6.2.2.6 PCI Configuration Menu

|   |               |   |  |
|---|---------------|---|--|
| PhoenixBIOS Setup Utility   |               |   |  |
| Advanced  |               |   |  |
| PCI Configuration   |               | Item Specific Help  |  |
| Reset Configuration Data:   | [No]          | Select 'Yes' if you want to clear the Extended System Configuration Data (ESCD) area. |  |
| <ul style="list-style-type: none"> <li>▶ PCI/PNP ISA UMB Region Exclusion</li> <li>▶ PCI/PNP ISA IRQ Resopurce Exclusion</li> </ul> |               |   |  |
| PCI IRQ line 1:   | [Auto Select] |   |  |
| PCI IRQ line 2:   | [Auto Select] |   |  |
| PCI IRQ line 3:   | [Auto Select] |   |  |
| PCI IRQ line 4:   | [Auto Select] |   |  |
| PCI IRQ line 5:   | [Disabled]    |   |  |
| PCI IRQ line 6:   | [Disabled]    |   |  |
| PCI IRQ line 7:   | [Disabled]    |   |  |
| PCI IRQ line 8:   | [Auto Select] |   |  |
| F1 Help ↑↓ Select Item -/+ Change Values F9 Setup Defaults<br>Esc Exit Select Menu Enter Select ▶ Sub-Menu F10 Save and Exit        |               |   |  |

| Feature                            | Options   | Description   |
|------------------------------------|---|---|
| PCI/PNP ISA UMB Region Exclusion   | See "PCI/PNP ISA UMB Region Exclusion" section.   |   |
| PCI/PNP ISA IRQ Resource Exclusion | See "PCI/PNP ISA IRQ Resource Exclusion" section. |   |
| PCI IRQ line 1                     | Disabled, Auto Select, 3-7, 9-12, 15              | IRQ assignment for PCI INT A. If set to Auto select BIOS will handle the IRQ setup. |
| PCI IRQ line 2                     | see above   | IRQ assignment for PCI INT B.   |

|                |           |  |
|----------------|-----------|--|
|                |           | If set to Auto select BIOS will handle the IRQ setup.                                  |
| PCI IRQ line 3 | see above | IRQ assignment for PCI INT C.<br>If set to Auto select BIOS will handle the IRQ setup. |
| PCI IRQ line 4 | see above | IRQ assignment for PCI INT D.<br>If set to Auto select BIOS will handle the IRQ setup. |
| PCI IRQ line 5 | see above | IRQ assignment for PCI INT E.<br>If set to Auto select BIOS will handle the IRQ setup. |
| PCI IRQ line 6 | see above | IRQ assignment for PCI INT F.<br>If set to Auto select BIOS will handle the IRQ setup. |
| PCI IRQ line 7 | see above | IRQ assignment for PCI INT G.<br>If set to Auto select BIOS will handle the IRQ setup. |
| PCI IRQ line 8 | see above | IRQ assignment for PCI INT H.<br>If set to Auto select BIOS will handle the IRQ setup. |

**6.2.2.7 PCI/PNP ISA UMB Region Exclusion Configuration Menu**

| PhoenixBIOS Setup Utility  |            |  |  |
|--|------------|--|--|
| Advanced   |            |  |  |
| PCI/PNP ISA UMB Region Exclusion   |            | Item Specific Help   |  |
| D000 - D3FF:   | [A viable] | Reserves the specified Block of upper memory for use by legacy ISA devices |  |
| D400 - D7FF:   | [A viable] |  |  |
| D800 - DBFF:   | [A viable] |  |  |
| DC00 - DFFF:   | [A viable] |  |  |
| F1 Help    ↑↓ Select Item    -/+ Change Values    F9 Setup Defaults<br>Esc Exit    Select Menu    Enter Select ► Sub-Menu    F10 Save and Exit |            |  |  |

| Feature  | Options             | Description   |
|--|---------------------|---|
| D000 – D3FF<br>D400 – D7FF<br>D800 – DBFF<br>DC00 – DFFF | Available, Reserved | Reserve this block of upper memory for use by legacy ISA devices. |

6.2.2.8 PCI/PNP ISA IRQ Resource Exclusion Configuration Menu

|                                    |                |   |                   |
|------------------------------------|----------------|---|-------------------|
| PhoenixBIOS Setup Utility          |                |   |                   |
| Advanced                           |                |   |                   |
| PCI/PNP ISA UMB Resource Exclusion |                | Item Specific Help                                      |                   |
| IRQ 3:                             | [Avable]       | Reserve the specified IRQ for use by legacy ISA devices |                   |
| IRQ 4:                             | [Avable]       |   |                   |
| IRQ 5:                             | [Avable]       |   |                   |
| IRQ 7:                             | [Avable]       |   |                   |
| IRQ 9:                             | [Avable]       |   |                   |
| IRQ 10:                            | [Avable]       |   |                   |
| IRQ 11:                            | [Avable]       |   |                   |
| IRQ 12:                            | [Avable]       |   |                   |
| IRQ 15 :                           | [Avable]       |   |                   |
| F1 Help                            | ↑↓ Select Item | -/+ Change Values                                       | F9 Setup Defaults |
| Esc Exit                           | Select Menu    | Enter Select ► Sub-Menu                                 | F10 Save and Exit |

| Feature | Options             | Description                                     |
|---------|---------------------|---|
| IRQ x   | Available, Reserved | Reserve this IRQ for use by legacy ISA devices. |

### 6.2.3 The Security Menu

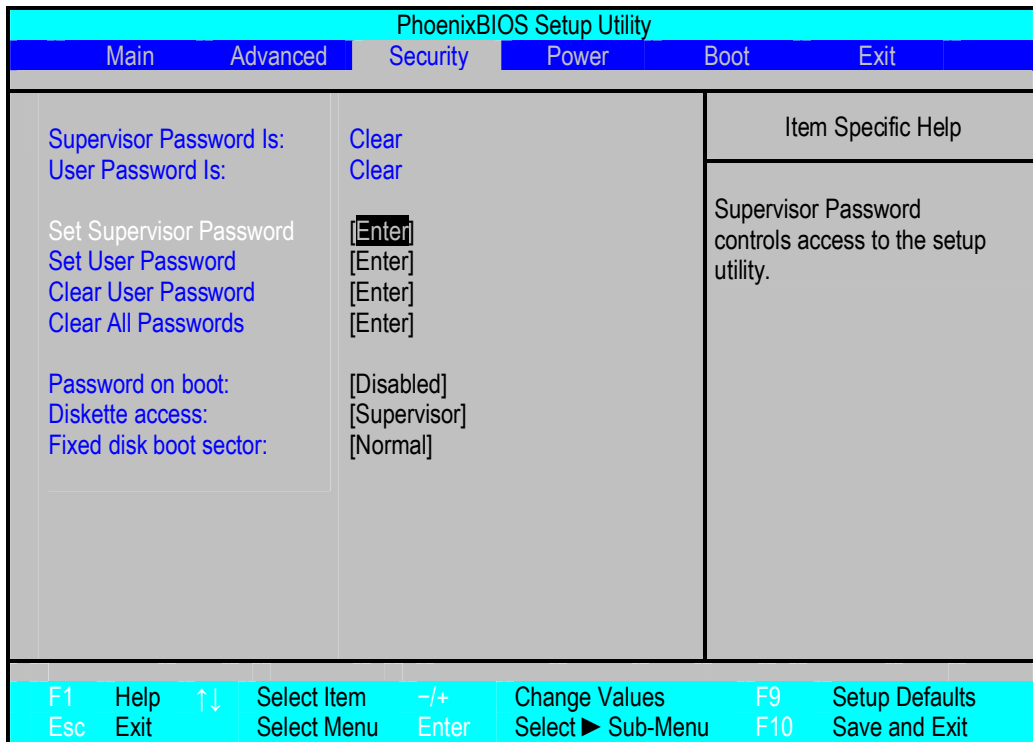

| Feature                 | Options                                  | Description   |
|-------------------------|--|---|
| Set Supervisor Password | ---                                      | The supervisor password controls the access to the setup utility.   |
| Set User Password       | ---                                      | Sets the user password.   |
| Clear User Password     | ---                                      | Clears the user password.   |
| Clear All Passwords     | ---                                      | Clears all passwords.   |
| Password on boot        | Disabled, Enabled                        | Enables password entry on boot.                                     |
| Diskette access         | User, Supervisor                         | Controls access to diskette drives by password.                     |
| Fixed disk boot sektor  | Normal, Write Protect                    | Write protects boot sector on hard disk to protect against viruses. |
| Supervisor Password Is  | Displays the supervisor password status. |   |
| User Password Is        | Displays the user password status.       |   |

## 6.2.4 The Power Menu

### 6.2.4.1 Power Menu Selections

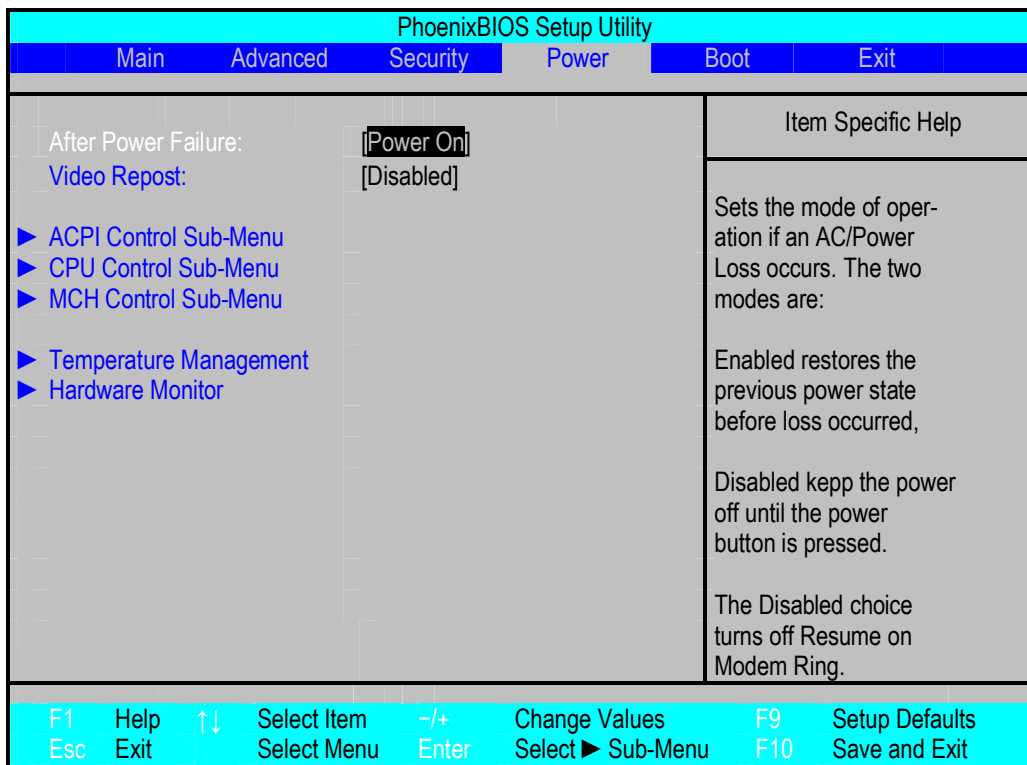

| Feature                | Options                                    | Description   |
|------------------------|--|---|
| After Power Failure    | Stay Off, Power On, Last State             | Sets the mode of operation if an AC power loss occurs.<br><b>Power On</b> will turn the power on as soon as the power supply is back on.<br><b>Stay Off</b> will keep the power off until the power button is pressed.<br><b>Last State</b> will only turn the power on, if the system was active when the power loss occurred. |
| Video Repost           | Disabled, Enabled                          | Controls the calling of a Video Repost to the VBIOS.  |
| ACPI Control Sub-Menu  | See "ACPI Control Sub-Menu" section.       |   |
| CPU Control Sub-Menu   | See "CPU Control Sub-Menu" section.        |   |
| MCH Control Sub-Menu   | See "MCH Control Sub-Menu" section.        |   |
| Temperature Management | See "Temperature Management Menu" section. |   |
| Hardware Monitor       | See "Hardware Monitoring Menu" section.    |   |

6.2.4.2 ACPI Control Sub-Menu

| PhoenixBIOS Setup Utility  |            | Power  |
|--|------------|--|
| ACPI Control Sub-Menu  |            | Item Specific Help   |
| ACPI – IO ACPI Mode:   | [Enabled]  | This item is valid Only for WIN 2000 and Windows XP. Also, a Fresh install of the OS must occur when ACPI Mode is desired.<br><br>Test the IOAPIC by Setting item to <i>Enabled</i> . The APIC Table will then be Pointed to by the RSTD, The Local APIC will be initialized, and the proper enable bits will be set in ICH4M. |
| HPET – High Performance Event Timer:   | [Disabled] |  |
| Native IDE Support:  | [Disabled] |  |
| F1 Help    ↑↓ Select Item    -/+ Change Values    F9 Setup Defaults<br>Esc Exit    Select Menu    Enter Select ► Sub-Menu    F10 Save and Exit |            |  |

| Feature            | Options           | Description   |
|--------------------|-------------------|---|
| ACPI               | Disabled, Enabled | Disable or Enable ACPI BIOS.  |
| HPET               | Disabled, Enabled | Only valid in the Windows XP OS.  |
| Native IDE Support | Disabled, Enabled | Native IDE support for WINXP is enabled or disabled by setting this item. The NATA Package will be created if this item is set to Enabled.<br><br><b>Note:</b> Changing this item will have no effect in WIN98, WINME or WIN2K. |

6.2.4.3 CPU Control Sub-Menu

| PhoenixBIOS Setup Utility  |  |
|--|--|
| Power  |  |
| CPU Control Sub-Menu   | Item Specific Help   |
| CPU Sleep: [Enabled]<br>Cx States: [Enabled]<br>Speed Step Technology: [Disabled]<br>Thermal Control Circuit: [TM1]                            | Select the type of Geyserville support desired.<br>If GV3 is selected, then the GV1 selection represents GV1 Plus.<br>Manual = IST Disabled, CPU set to desired Voltage/Frequency. |
| F1 Help    ↑↓ Select Item    -/+ Change Values    F9 Setup Defaults<br>Esc Exit    Select Menu    Enter Select ► Sub-Menu    F10 Save and Exit |  |

| Feature               | Options               | Description   |
|-----------------------|-----------------------|---|
| CPU Sleep             | Disabled, Enabled     | Enables the CPU_SLP# signal to go active in the C3 and C4 states to reduce CPU power.<br><b>Note:</b> CPU_SLP# will always go active during IST (Intel Speed Stepping) and Sx states.   |
| Cx States             | Disabled, Enabled     | Enable the ability to enter into Cx states when running an APM operating system.  |
| Speed Step Technology | GV3, Manual, Disabled | <b>GV3</b> = Intel Speed Step Technology. This feature changes the CPU frequency and CPU voltage automatically according to the current CPU load and CPU temperature.<br><b>Manual</b> = User setting to a fixed frequency. No speed stepping is done at all.<br><b>Disabled</b> = the CPU frequency and CPU frequency are set to the highest possible states.<br><b>Warning:</b> If the GV3 feature is not enabled the possibility of overheating the CPU increases! |

|                         |                    |   |
|-------------------------|--------------------|---|
| Thermal Control Circuit | Disabled, TM1, TM2 | <p>Enables the Thermal Monitor feature of the CPU. In case of an overheated CPU <b>TM1</b> reduces the CPU duty cycle to 50%. <b>TM2</b> uses the Intel Speed Step Technology to switch to a lower CPU frequency and CPU voltage.</p> <p>TM2 is only available in connection with "Speed Step Technology" set to GV3.</p> |
|-------------------------|--------------------|---|

6.2.4.4 MCH Control Sub-Menu

|                             |                |  |                   |
|-----------------------------|----------------|--|-------------------|
| PhoenixBIOS Setup Utility   |                |  |                   |
| Advanced                    |                |  |                   |
| MCH Control Sub-Menu        |                | Item Specific Help                             |                   |
| DIMM Clock Gating:          | [Enabled]      | Control Enabling of DIMM Clock Gating Feature. |                   |
| DRPM Support:               | [Enabled]      |  |                   |
| Chipset Thermal Throttling: | [Enabled]      |  |                   |
| F1 Help                     | ↑↓ Select Item | -/+ Change Values                              | F9 Setup Defaults |
| Esc Exit                    | Select Menu    | Enter Select ► Sub-Menu                        | F10 Save and Exit |

| Feature                    | Options           | Description  |
|----------------------------|-------------------|--|
| DIMM Clock Gating          | Disabled, Enabled | Enables the DIMM Clock Gating Feature.   |
| DRPM Support               | Disabled, Enabled | If enabled, this feature will turn off the memory clocks when not in use.  |
| Chipset Thermal Throttling | Disabled, Enabled | This enables or disables Cipset Thermal Throttling. Enabled means that thermal events will trigger read and write DRAM throttling (20%). |

### 6.2.4.5 Hardware Monitoring Menu

| PhoenixBIOS Setup Utility  |                |                         |
|--|----------------|-------------------------|
| Power  |                |                         |
| Hardware Monitor   |                | Item Specific Help      |
| Vcore  | =              | 0.89 V                  |
| Vram (+2.5V)   | =              | 2.52 V                  |
| Vcc (+3.3V)  | =              | 3.36 V                  |
| Vin1 (+1.5V)   | =              | 1.52 V                  |
| Vin2 (+1.05V)  | =              | 1.04 V                  |
| CPU Temperature  | =              | 49 °C                   |
| Board Temperature  | =              | 48 °C                   |
| Throttling Status  |                | Inactive                |
| All items on this menu cannot be modified in user mode. If any items require changes, please consult your system Supervisor. |                |                         |
| F1 Help  | ↑↓ Select Item | -/+ Change Values       |
| Esc Exit   | Select Menu    | Enter Select ► Sub-Menu |
|  |                | F9 Setup Defaults       |
|  |                | F10 Save and Exit       |

| Feature           | Description                             |
|-------------------|---|
| Vcore             | Displays the current CPU voltage.       |
| Vram (+2.5)       | Displays the current voltage.           |
| Vcc (+3.3)        | Displays the current voltage.           |
| Vin1 (+1.5)       | Displays the current voltage.           |
| Vin2 (+1.05)      | Displays the current voltage.           |
| CPU Temperature   | Displays the current CPU Temperature.   |
| Board Temperature | Displays the current Board Temperature. |
| Throttling Status | Displays the current throttling status. |

### 6.2.4.6 Temperature Management Menu

| PhoenixBIOS Setup Utility  |          |  |
|--|----------|--|
| Power  |          |  |
| Temperature Management   |          | Item Specific Help   |
| CPU Clock Throttling   | [50%]    | CPU clock will be throttled by the selected value when reaching the temperature threshold. |
| CPU Alarm Temperature  | [80°C]   |  |
| CPU Alarm Hysteresis   | [5°C]    |  |
| Throttling Status  | Inactive |  |
| F1 Help    ↑↓ Select Item    -/+ Change Values    F9 Setup Defaults<br>Esc Exit    Select Menu    Enter Select ► Sub-Menu    F10 Save and Exit |          |  |

| Feature               | Options                                 | Description  |
|-----------------------|---|--|
| CPU Clock Throttling  | 75%, 50%, 25%, 12,5%                    | If the CPU temperature reaches the set temperature set in "CPU Alarm Temperature" the CPU clock will be throttled by this value. |
| CPU Alarm Temperature | 65°C, 70°C, 75°C, 80°C, 85°C, 90°C      | Sets the CPU temperature at which the CPU clock will be throttled by the value set in "CPU Clock Throttling".                    |
| CPU Alarm Hysteresis  | 3°C, 4°C, 5°C, 6°C                      | Sets the temperature by which the set CPU Alarm Temperature has to decrease in order to stop CPU clock throttling again.         |
| Throttling status     | Displays the current throttling status. |  |

### 6.2.5 The Boot Menu

After you turn on your computer, it will attempt to load the operating system (such as DOS, Windows XP or Linux) from the device of your choice. If it cannot find the operating system on that device, it will attempt to load it from one or more other devices in the order specified in the Boot Menu. Boot devices (i.e., with access to an operating system) can include: hard drives, floppy drives, CD ROMs, removable devices (e.g. USB sticks), and network cards.

**Note:** Specifying any device as a boot device on the Boot Menu requires the availability of an operating system on that device. Most PCs come with an operating system already installed on hard-drive C:

Selecting "Boot" from the Menu Bar displays the Boot menu, which looks like this:

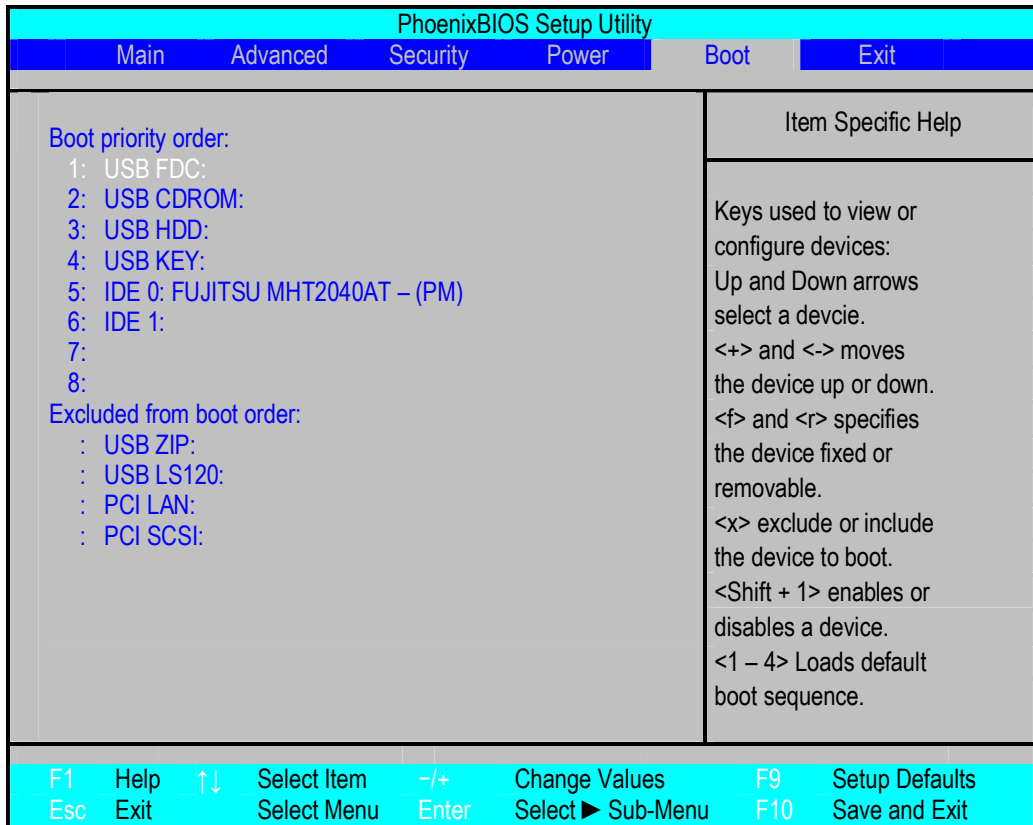

## 6.2.6 The Exit Menu

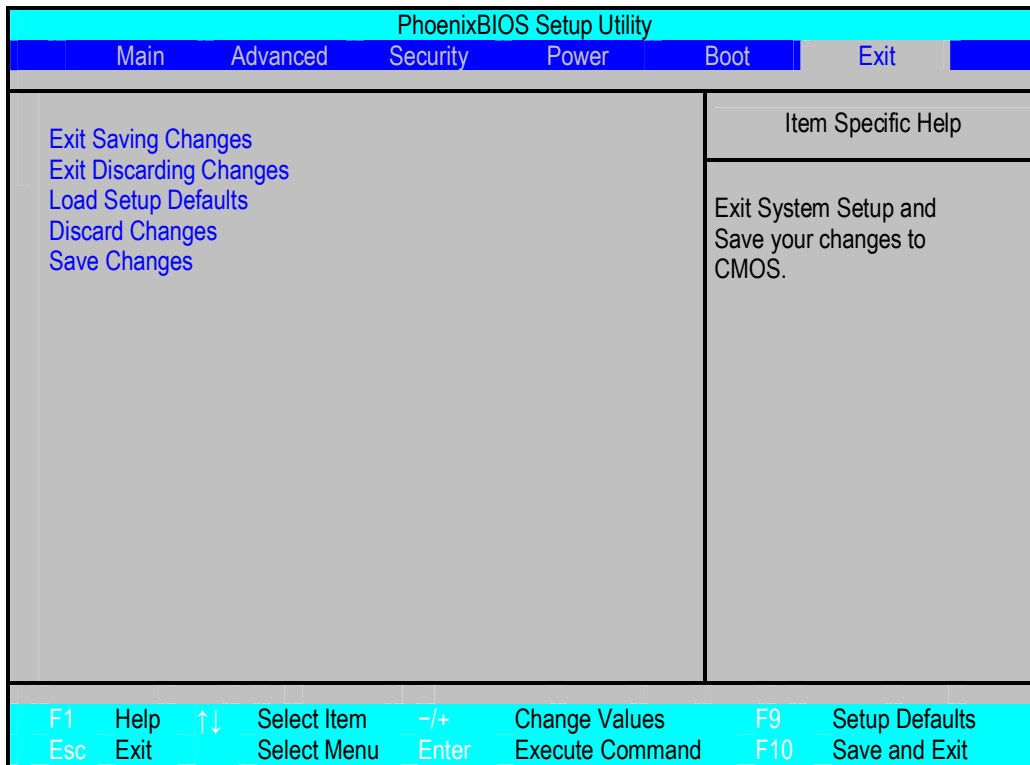

The following sections describe each of the options on this menu. Note that <Esc> does not exit this menu. You must select one of the items from the menu or menu bar to exit.

### 6.2.6.1 Exit Saving Changes

After making your selections on the Setup menus, always select "Exit Saving Changes". This procedure stores the selections displayed in the menus in CMOS (short for "battery-backed CMOS RAM") a special section of memory that stays on after you turn your system off. The next time you boot your computer, the BIOS configures your system according to the Setup selections stored in CMOS.

If you attempt to exit without saving, the program asks if you want to save before exiting. During bootup, PhoenixBIOS attempts to load the values saved in CMOS. If those values cause the system boot to fail, reboot and press <F2> to enter Setup. In Setup, you can get the Default Values (as described below) or try to change the selections that caused the boot to fail.

### 6.2.6.2 Exit Discarding Changes

Use this option to exit Setup without storing in CMOS any new selections you may have made. The selections previously in effect remain in effect.

### 6.2.6.3 Load Setup Defaults

To display the default values for all the Setup menus, select "Load Setup Defaults" from the Main Menu.

If, during bootup, the BIOS program detects a problem in the integrity of values stored in CMOS, it displays these messages:

**System CMOS checksum bad - run SETUP Press <F1> to resume, <F2> to Setup**

The CMOS values have been corrupted or modified incorrectly, perhaps by an application program that changes data stored in CMOS.

Press <F1> to resume the boot or <F2> to run Setup with the ROM default values already loaded into the menus. You can make other changes before saving the values to CMOS.

#### **6.2.6.4 Discard Changes**

If, during a Setup Session, you change your mind about changes you have made and have not yet saved the values to CMOS, you can restore the values you previously saved to CMOS.

Selecting "Discard Changes" on the Exit menu updates all the selections with their previous values.

#### **6.2.6.5 Save Changes**

Selecting "Save Changes" saves all the selections without exiting Setup. You can return to the other menus if you want to review and change your selections.