

# DanoTech

# Capacitive Controller Specification

Model No.:C3100

Date: April 7, 2009

Product: Capacitive Controller

Rev.:V1.106

Document No.:SP-C3100-103

Page:1/3

Item		Specification
<b>Hardware Specifications</b>		
1	Circuit Board Dimension	62mm×33mm(2.48inches×1.29inches)
2	Power Requirements	D.C.+5V External power 5~12VDC unRegulated Power (max. 65mA, typical 55mA, 50mV peak to peak Max ripple)
3	Operating Temperature	-40 to 80 degrees Centigrade
4	Storage Temperature	-40 to 90 degrees Centigrade
5	Relative Humidity	95% at 60 degrees Centigrade
6	Interface(cable select)	Auto-detection : ➤ RS232 : 9600 bauds, None parity, 8data bits, 1 stop bit ➤ USB : USB 2.0 compliant, full speed
7	Resolution	2048*2048
8	Frequency Adjustment	Auto-scan
9	Accuracy Tolerance	Max. +/-1%
10	Report Rate	Max. 180 points/sec
11	Response Time	Max. 25ms
12	Attached Cable	RS232: 6' shielded cable with 9-pin USB: 6' shielded cable with A type connector for USB Y converter cable
13	ESD	±27 KV Air, ±8 KV Contact
14	Regulatory Approvals	FCC-B, CE
15	Green Product	RoHS
16	EMI	Unaffected by environmental EMI
17	Pin Out Definition	UL, UR, COM, LR, LL
Item		Specification
<b>Software Specifications</b>		
1	Calibration	Fast full oriental 4 points position
2	Compensation	➤ Accuracy 9, 25 points linearity position ➤ Edge compensation

Model No.:C3100

Date: April 7, 2009

Product:Capacitive Controller

Rev.: V1.106

Document No.:SP-C3100-103

Page:2/3

Item		Specification
<b>Software Specifications</b>		
3	Draw Test	Position and linearity verification
4	Controller Setting	<ul style="list-style-type: none"> <li>➤ Support multiple controllers</li> <li>➤ Dynamical add/remove controllers</li> <li>➤ Change controller interface without reboot</li> </ul>
5	Languages	Support 11 languages for Windows
6	Mouse Emulator	<ul style="list-style-type: none"> <li>➤ Right/left button emulation</li> <li>➤ Click/drawing mode</li> </ul>
7	Sound Notification	<ul style="list-style-type: none"> <li>➤ No sound</li> <li>➤ Touch down</li> <li>➤ Touch up</li> </ul>
8	Double Click	<ul style="list-style-type: none"> <li>➤ Configurable double click speed</li> <li>➤ Configurable double click area</li> </ul>
9	HID Touch Digitizer	➤ Support Vista HID Touch Digitizer
10	OS Support	<ul style="list-style-type: none"> <li>➤ Windows Vista / XP / 2000 / XP server 2003</li> <li>➤ Windows 95 / 98 / ME / NT4 / XP Tablet PC edition</li> <li>➤ Windows CE 2.12 / 3.0 / .net (4.0, 5.0, 6.0)</li> <li>➤ Linux (up to Kernel 2.6)</li> <li>➤ MS-DOS: support display resolution:320 x200, 640x200, 640x350, 640x480, 800x600, 1024x768 and 1280x1024</li> <li>➤ iMac 9.0 / OS X (Power PC, Intel CPU)</li> <li>➤ QNX</li> </ul>
11	COM Port Support	<ul style="list-style-type: none"> <li>➤ Support COM1-COM 255 for Windows and Linux</li> <li>➤ Support COM1~COM8 for DOS</li> </ul>
12	Display Support	<ul style="list-style-type: none"> <li>➤ Support monitor/ display rotation</li> <li>➤ Support multiple monitors</li> <li>➤ Support split monitor</li> </ul>

Model No.:C3100

Date: April 7, 2009

Product:Capacitive Controller

Rev.:V1.106

Document No.:SP-C3100-103

Page:3/3

Figure 1: Controller Diagram

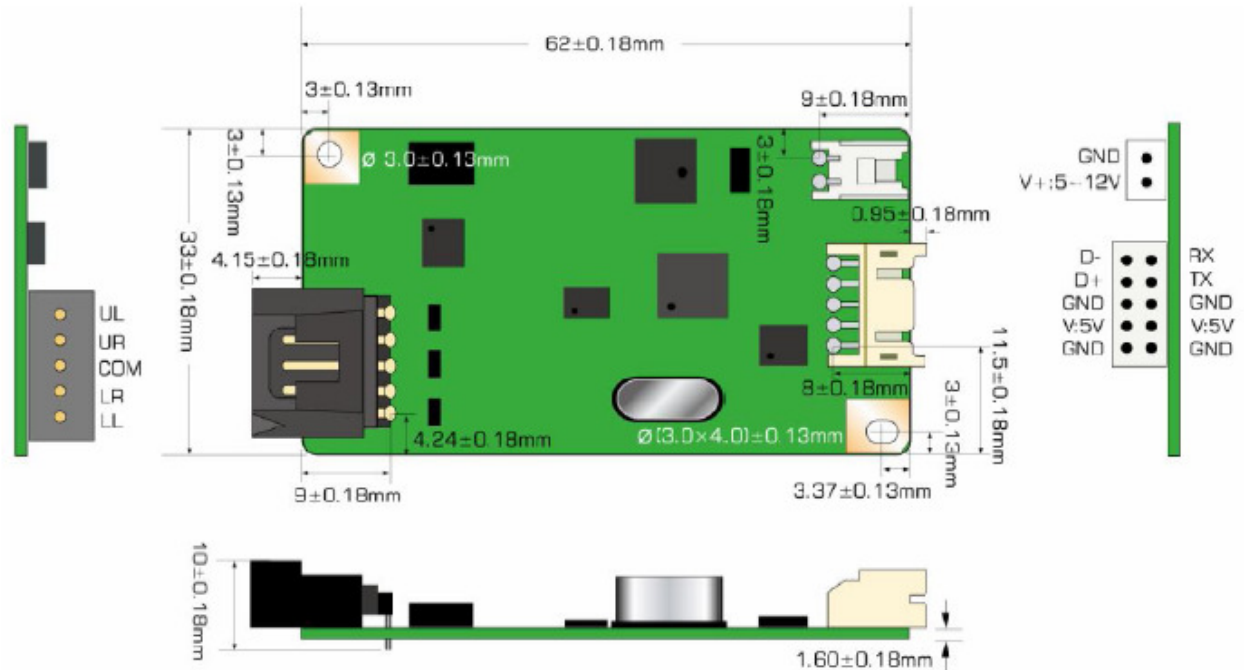
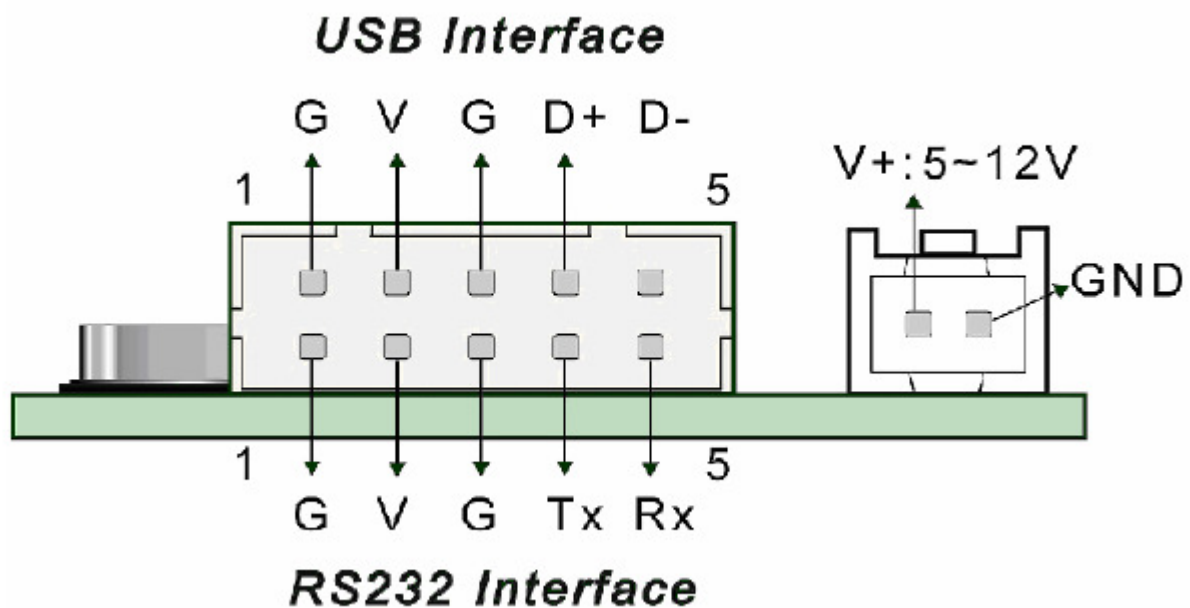

Figure 2: Pin Assignment



締環產品承認書  
SPECIFICATION FOR APPROVAL

客戶 **鑫科資訊股份有限公司**  
Customer \_\_\_\_\_

產品名稱 **10P HOUSING / 5\*2P HOUSING**  
Description **CABLE 5CM**

客戶產品料號 **ETP-CB-SXC00**  
Customer Part No. \_\_\_\_\_

締環公司料號 **06AXX090**  
GoodPlus Part No. \_\_\_\_\_

製作日期 **18. 5. 2006**  
Manufactured Date \_\_\_\_\_

客戶公司承認章 Customer Approval

締環資訊科技有限公司 GOODPLUS TECHNOLOGY CO., LTD

締環資訊科技有限公司  
GOODPLUS TECHNOLOGY CO., LTD  
台北市內湖區成功路4段68號8F-2  
8F-2,NO.68,SEC.4,CHENGGONG RD.,NEIHU  
DISTRICT, TAIPEI CITY 114, TAIWAN,R.O.C.  
TEL : 886-2-27914338      FAX : 886-2-26924258

---

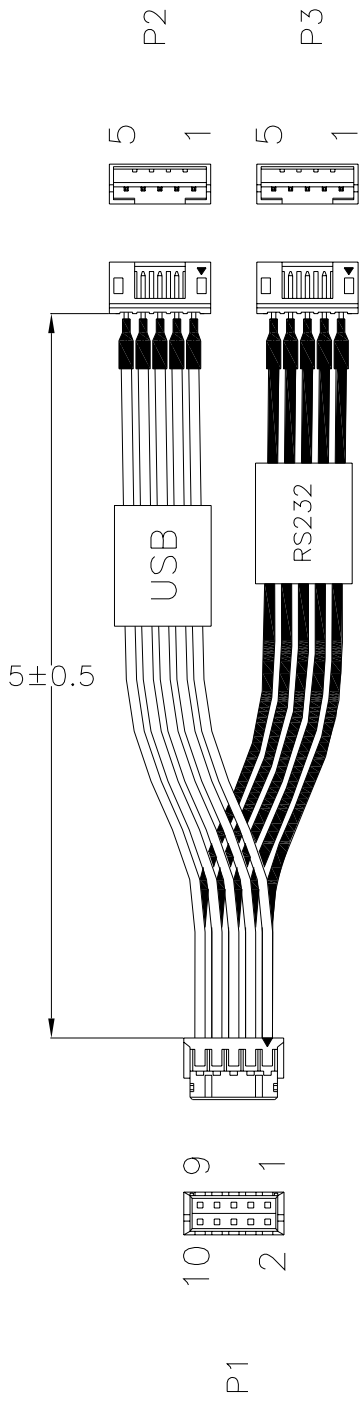

PIN ASSIGNMENT

=====

P1	P2	P3
1	1	1
3	2	2
5	3	3
7	4	4
9	5	5
2		1
4		2
6		3
8		4
10		5

MATERIAL LIST :

WIRE :

UL1007 26AWG 80°C 300V , COLOR : WHITE & BLACK .

CONNECTOR :

P1 : 2.0 PITCH 5\*2 PIN DUAL ROW HOUSING .

P2 , P3 : 2.0 PITCH 5 PIN SINGLE ROW WAFER .

MARKER :

OM TYPE WIRE MARKERS , 6.5\*19mm , COLOR : WHITE .

**GOOD PLUS CO., LTD.**

DESCRIPTION : 10P/5P\*2 HOUSING 5CM

ISSUE : 95/5/15

CUSTOMER No.: ETP-CB-SXC00

PAGE : 1 OF 1

PART No. : 06AXX090

REV : A

CHECK : VINCENT

UNIT : CM