

Introduction

This application note outlines the use of the ispPAC[®]10 in differential circuits for bridge networks. The ispPAC10 architecture is well suited for instrumentation measurement since both inputs and outputs are differential. In-System Programmability (ISP[™]) and programmable gain control allow the user to reconfigure the device characteristics after it is soldered onto a circuit board. System offset errors can be calibrated out and gain errors can be adjusted using the ispPAC10 as a programmable gain stage.

ispPAC10 Overview

The ispPAC10 contains four programmable analog modules called PACblocks. Refer to Figure 1 for the basic structure of the PACblock. Each PACblock contains a differential-output summing amplifier (OA) and two differential-input instrumentation amplifiers (IAs) with variable gains of ± 1 to ± 10 in integer steps. The OA's feedback path contains a resistive element which can be switched in or out, as well as a programmable capacitor array that allows for more than 120 poles when the ispPAC10 device is used as an active filter. Thus, each PACblock has the ability to sum two differential signals with independently-selectable gain and inversion settings and to act as a gain element (with the feedback switch closed) or as an integrator (with the feedback switch open).

The gain settings, feedback, capacitor values and internal interconnects between PACblocks are configurable through non-volatile E²C^{MOS}[®] cells internal to the ispPAC10. The device configuration is set by software and downloaded to the device via a JTAG download cable.

Figure 1. A Single PACblock

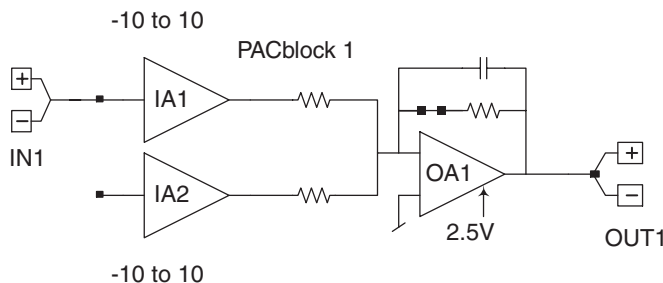
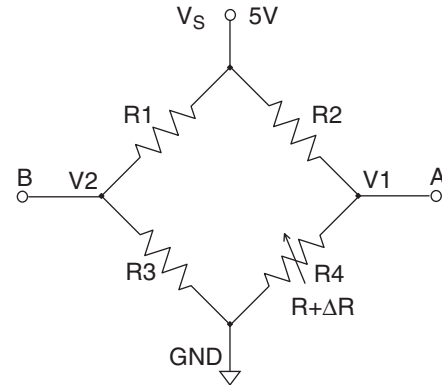

Figure 2. Typical Passive Bridge



Bridge Circuits

Bridge circuits fundamentally contain a group of elements in which at least one element's characteristics change with applied external stimulus. The stimuli may include temperature, force, pressure or strain. Figure 2 shows a typical bridge network formed from passive elements.

The main function of the bridge is to expose small changes in voltage or current caused by a perturbation of the bridge structure. The small voltage deviations can range from a few microvolts to hundreds of millivolts. Without the bridge's balancing function, it is very difficult to resolve these deviations relative to the entire voltage that appears across an individual element.

The small voltage change that is the output of most bridges can be amplified using the ispPAC10. The gain of each PACblock can be as high as ± 10 . Using the four PACblocks in an ispPAC10, a gain of up to 10,000 (80 dB) can be realized. The device's feedback capacitors can also be chosen for lowest noise, if desired.

When the branch elements are arranged in the standard four-element bridge configuration, the desired output is the difference in node voltages between node 'A' and node 'B.' Since the ispPAC10 inputs are differential, circuit connections are easily made while the component count is kept to a minimum. In order to interface properly to the bridge, high impedance differential inputs are needed. The input impedance of the ispPAC10 is typically 1×10^9 ohms, more than high enough for the measurement accuracy to not be affected due to input loading. The outputs of the ispPAC10 are also differen-

Bridge Measurements Using In-System Programmable Analog Circuits

tial, making its integration into other measurement circuitry easier. And, the input and output offsets of the ispPAC10 are typically 200 μV after the device's automatic input offset calibration, making it one of the lower-offset devices available.

Another advantage of the ispPAC10 is in-system-programmability, which makes it possible to reconfigure the device for various load sensitivities or sensor types after it is installed. This helps to make the ispPAC10 a versatile solution for industrial-grade differential measurements.

There are many subtle issues that arise when trying to measure small signals in the presence of noise and distortion-causing effects. Included are thermal issues and thermocouple effects due to dissimilar metals used in the contacts of the sensor. It is also important to understand the linearity of the sensor and how it affects the interface to the measurement circuit.

Most resistive bridge circuits are based upon the fact that the sensor element changes resistance with an applied external stimulus such as force or pressure. For a single resistive strain-gage element, the equivalent mathematical function is expressed as $R+(\Delta R)$, where the ΔR is the value that changes with applied external stimulus. A problem arises when there is also a change in temperature, because the sensor will now be affected by two stimuli. If the effects of the temperature coefficient are limiting the overall resolution and accuracy of the measurement, then the bridge can be set up with temperature compensation included.

There are simple methods to compensate for changes in the sensor resistance due to temperature. The easiest solution is to place multiple sensors in the bridge. For resistive-element bridge setups, the main sensor element can have a complement element mounted on the same thermal substrate. The effects of temperature changes are cancelled out due to the fact that the dummy gage has the same temperature coefficient as the sensor gage. See Figure 3 for this configuration.

Equations for a single sensor:

$$V_{OUT} = (V1 - V2)$$

$$V_{OUT} = (V_S) * \left(\frac{R + \Delta R}{2R + \Delta R} - \frac{R}{2R} \right)$$

$$V_{OUT} = (V_S) * \left(\frac{\Delta R}{4R + 2\Delta R} \right)$$

$$V_{OUT} \cong (V_S) * \left(\frac{\Delta R}{4R} \right)$$

Figure 3. Bridge with Temperature Comp. Gage

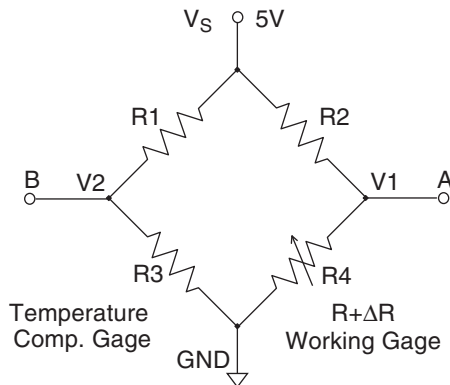

The approximation for V_{OUT} assumes that the denominator for this function is approximately $4R$ due to the fact that the small ΔR is much smaller than R and can therefore be neglected.

Most manufacturers design strain gage elements with complementary branches for temperature compensation. These are typically arranged in an orthogonal layout such that one gage is parallel to the strain direction and the dummy gage is rotated 90 degrees so it is not affected by the strain and adds only temperature compensation. See Figure 4 for this compensation gage.

Figure 4. Strain Gage with Temp. Comp. Element

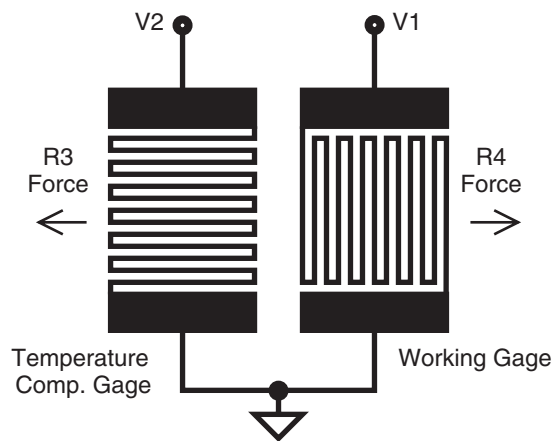

To increase the gain of the bridge network itself, a second element can be added in the opposite branch of the bridge along with its complement as a temperature compensator. This is shown in Figure 5. This configuration yields the following equations:

Bridge Measurements Using In-System Programmable Analog Circuits

Equations for two sensors:

$$V_{OUT} = V1 - V2$$

$$V_{OUT} = (V_S) \left(\frac{R + \Delta R}{2R + \Delta R} - \frac{R}{2R + \Delta R} \right)$$

$$V_{OUT} = (V_S) * \left(\frac{\Delta R}{2R + \Delta R} \right)$$

$$V_{OUT} \cong (V_S) * \left(\frac{\Delta R}{2R} \right)$$

Figure 5. Two-element Bridge with Temp. Comp.

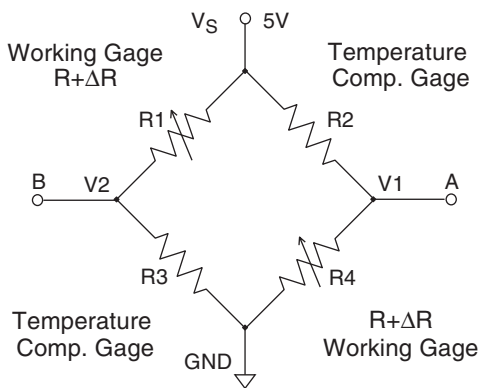

Further gain and linearity improvements can be achieved by placing the elements on opposite sides of the stressed member. With this configuration, the linearity and the gain are enhanced because one set of gages is under compression while the other set is under tension. The overall output is now more linear with stress and compensated for temperature (Figure 6). The four-gage bridge gives the most accurate measurements because of these advantages. The equations for a four-element bridge are shown below:

Equations for four sensors:

$$V_{OUT} = V1 - V2$$

$$V_{OUT} = (V_S) * \left(\frac{R + \Delta R}{2R} - \frac{R - \Delta R}{2R} \right)$$

$$V_{OUT} \cong (V_S) * \left(\frac{\Delta R}{R} \right)$$

Figure 6. Four-element Bridge

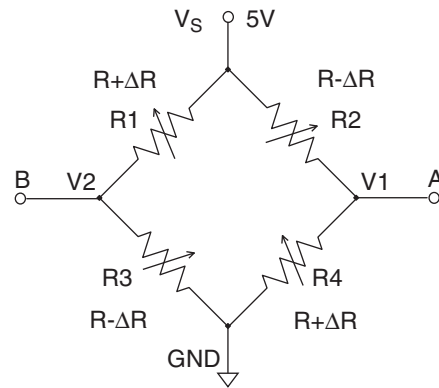

Please refer to specific gage manufacturers for specifications on mounting techniques, linearity and temperature coefficients. Web sites such as sensorsmag.com offer large lists of sensor manufacturers.

The ispPAC10 will easily interface to any type of bridge network, from a single element coupled with other resistors to a full bridge with all four elements acted on by the stimulus. The inputs to the PAC10 are differential and must be within the bounds for its input common mode voltage, centered around 2.5V. Therefore, it is easier to use a bridge that uses a 5V supply, making the V1 and V2 nodes centered at 2.5V due to the voltage divider action of the bridge.

Figure 7 shows a typical configuration for a two-element differential bridge measurement. This configuration can be used for various types of bridges and can be reconfigured for gain changes due to bridge element limitations. The gain shown above is 100 overall, with each PAC10 block programmed for a gain of 10 (recall that each PACblock is capable of independent gain programming in integer steps of ± 1 to ± 10). The differential output can then be sampled by a differential A/D converter and converted to a digital value for further processing.

Another application of the ispPAC10 for bridge measurements is to drive the bridge using the differential outputs of the device. This allows referencing the excitation voltage to the ispPAC10's stable V_{REFOUT} , as well as isolating the bridge from a noisy supply or ground. The ispPAC10 device can be set up to supply a differential 3V excitation, and its 10mA minimum guaranteed output current is more than adequate for many bridge devices. Further details can be found in AN6005, *ispPAC10: Complete Interface for Bridge Sensor to 12-bit ADC*.

Bridge Measurements Using In-System Programmable Analog Circuits

Figure 7. ispPAC10 Configured as a Differential Bridge Gain Stage

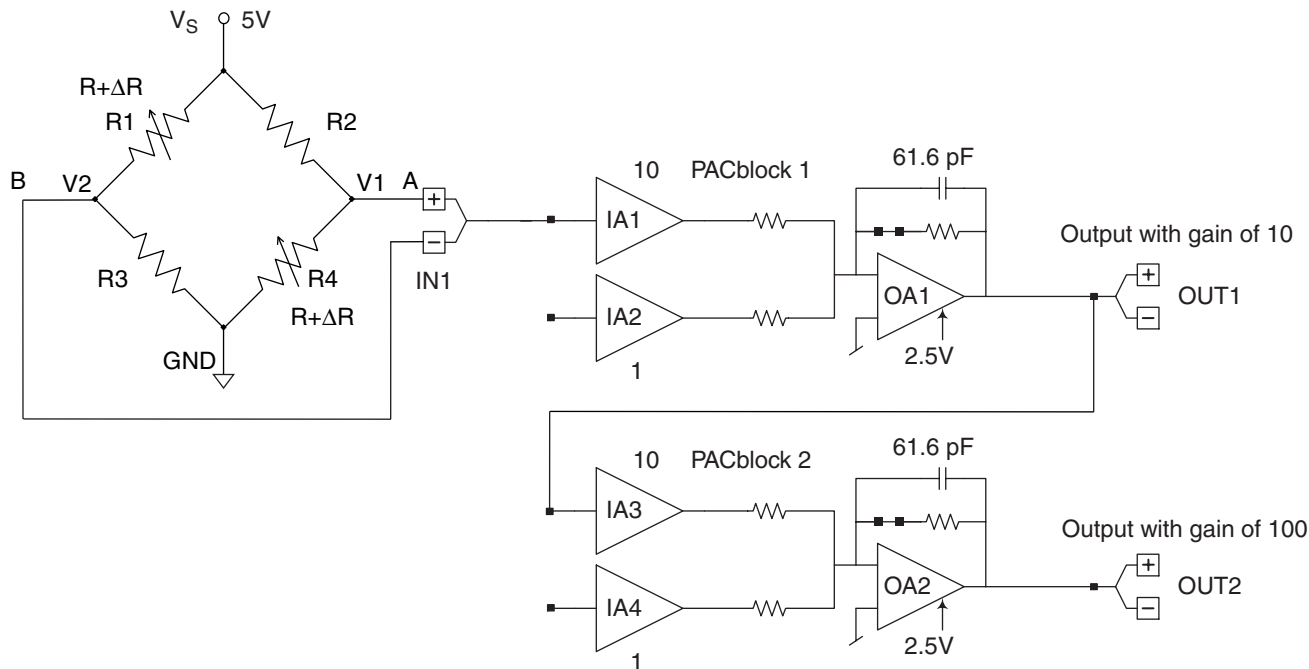

Small Step Gain Adjustments

For calibration of the gain and small step adjustments, an external voltage divider can be used to increase the resolution of the gain steps to as high as 0.1%. This topic is outlined in more detail in Application Note AN6007, *In-System Programmable Gain with Fractional Gain Adjustments*. Please refer to AN6007 and the ispPAC10 Data Sheet for further details.

Summary

The ispPAC10 easily interfaces to any type of bridge network, from single element circuits with temperature compensation to four-element circuits where all four elements are acted on by the stimulus. In particular, the very-high-impedance differential inputs and the low-off-set-voltage balanced outputs of the ispPAC10 make it ideal for use in bridge measurement circuits. The device also offers the advantages of a flexible architecture and the capability to reconfigure the device parameters, such as gain and filter characteristics, while the device is on a circuit board. Gain factors can be set or changed by software and the part can be reconfigured by external downloading or by an embedded microprocessor, local to the board or system.

Technical Support Assistance

Toll Free Hotline: 1-800-LATTICE (Domestic)
 International: 1-408-826-6002
 E-mail: ispPACs@latticesemi.com
 Internet: <http://www.latticesemi.com>