

## Introduction

The differential inputs provided on ispPAC<sup>®</sup> products provide a significant degree of flexibility as electronic signal interfaces. This application note describes several examples of how ispPAC products can be interfaced to various signal sources.

## Signal Input Ranges for ispPAC Products

The first thing one needs to know to effectively interface signals to ispPAC inputs are the allowable ranges for input signals at the  $V_{in+}$  and  $V_{in-}$  terminals (Figure 1a). The guaranteed minimum and maximum values for these signals are shown in Figure 1b. Note that different members of the ispPAC product family have different ranges, with the ispPAC30 able to sense signals down to 0V or 'ground'.

**Figure 1. ispPAC Common-mode Input Ranges**

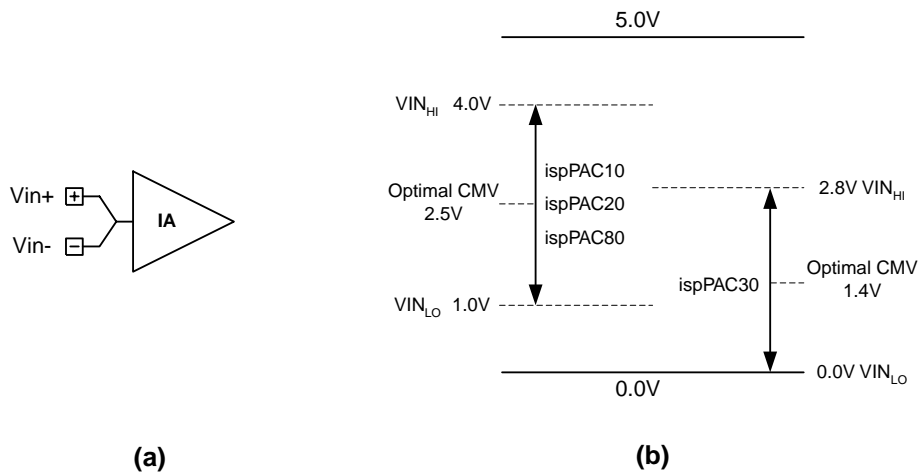

In addition to the minimum and maximum allowable voltages at the individual input terminals, two related voltages are the common-mode voltage and the differential voltage. The common-mode voltage is the average of the voltages at the two input terminals. The differential voltage is the difference between the voltages at the two input terminals. See AN6019, *Differential Signaling*, for a detailed discussion of differential signals.

The common-mode value of a signal is important because it affects the range of differential signals that can be accurately measured. As the common-mode value of a signal approaches either input limit, the allowable differential signal that can 'ride' on top of that common-mode signal approaches zero. As an example, an ispPAC10, with a common-mode input range from +1 to +4V, has maximum differential input range ( $\pm 3V$ ) when the common-mode voltage is halfway between the two limits, at 2.5V. If one moves the common mode voltage to +2V, however, the lowest level either signal can drop to (and still remain within the linear range of the input amplifier) is still limited to +1V. This results in a reduction of the differential signal range to  $\pm 2V$ . Figure 1b shows the 'optimal' common-mode input voltages (CMV) that result in maximum differential for the present members of the ispPAC family product line (ispPAC10/20/30/80).

## Interfacing to Differential Signal Sources

The differential inputs provided on ispPAC devices provide a natural interface to many intrinsically balanced signal sources such as sensors and transducers. One key to successfully interfacing to ispPAC inputs (or any other differential amplifier) is to ensure that the common-mode value of the transducer signal is well within the device's acceptable input range.

Figure 2. Examples of Differential Sources Providing Common-mode Bias

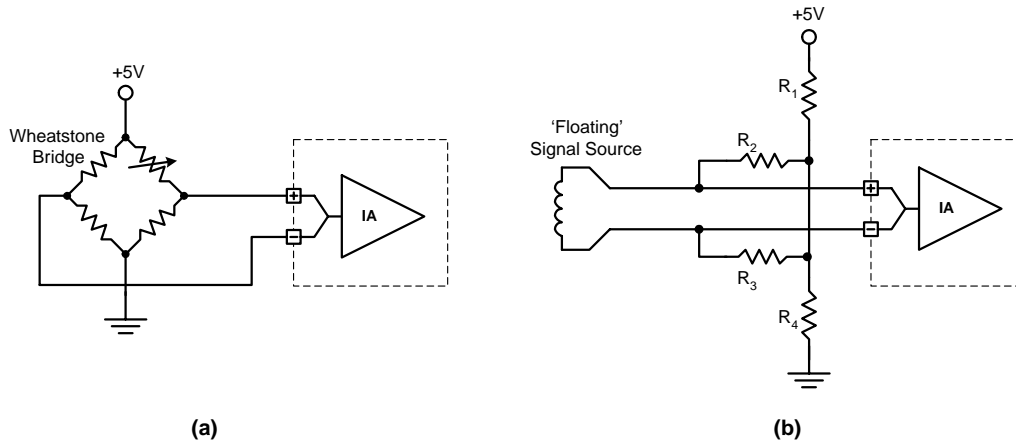
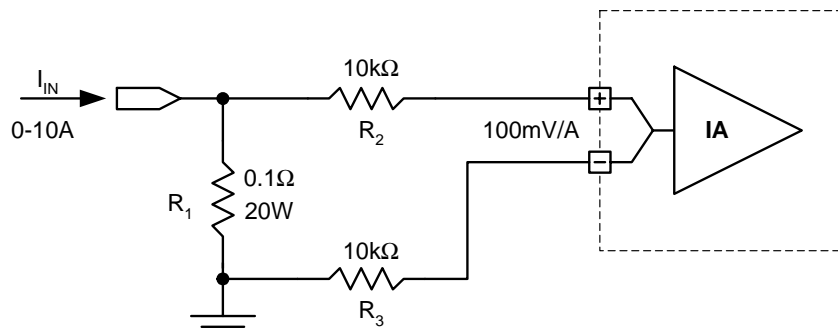

Figure 2 shows two examples of how balanced-output transducers can be interfaced to ispPAC inputs. The first case (Figure 2a) shows how the outputs of a Wheatstone bridge can be fed directly into the ispPAC input. The Wheatstone bridge is a popular circuit configuration for resistive-type sensors such as strain gauges and pressure transducers precisely because it develops a balanced voltage output proportional to the relative change of the resistors comprising it. In the case of a bridge where all the resistors are nominally equal, the common-mode output voltage will be one half of the bias voltage. In the case shown above, where the bridge is biased from a +5V source, the common-mode output is 2.5V, allowing the bridge output to be connected directly to the ispPAC10 input.

The second example, Figure 2b, shows an interface scheme suitable for use with a 'floating' voltage source such as a dynamic microphone or inductive pickup. In this DC-coupled example, the source must be artificially biased up to an acceptable common-mode voltage. This is accomplished by the network comprising R1 through R4. R1 and R4 form a divider that sets the bias level, in this case given by  $V_{BIAS} = (5V \times R_4) / (R_1 + R_4)$ . The positive and negative signal lines are pulled to this bias level through R2 and R3. Using this 'star' bias network is preferable to individually biasing each input line with a separate resistive divider because resistor mismatches in this scheme do not directly develop input offset voltage errors.

Because the ispPAC30's common-mode input range extends down to ground, this part is straightforward to use in applications with ground-referenced signals. An example of such an application is the current sensor shown in Figure 3. A 0-10A current input develops a voltage ranging from 0-1V across the 0.1Ω sense resistor. This application also illustrates one of the primary benefits of differential signal processing. Although one can sense the voltage at the resistor's input terminal with a single-ended amplifier, this assumes that the ground terminal of the resistor is really at ground. At ampere-level currents, this is an often unwarranted assumption which can result in significant measurement errors. By sensing the actual voltage at both resistor terminals one can avoid this source of measurement error.

Figure 3. ispPAC30 Sensing Differential Signals Near Ground



In this particular application, where high currents are being measured, there may be the possibility that the voltages at the resistor terminals exceed those that the ispPAC30 can safely handle. If the input voltage becomes lower than -0.6V or higher than +5.6V, input protection diodes inside the device will begin to turn on and shunt input current to either ground or the positive power supply. In this case, since current available at the inputs can reach several Amperes, significant damage to the ispPAC30 could result if this occurs. Resistors R<sub>2</sub> and R<sub>3</sub> protect against this possibility, by limiting maximum input current to safe levels (mA range) that the device's input protection networks can readily handle.

One way to expand the acceptable input signal range is to use a resistive attenuation network, such as that shown in Figure 4. This circuit simultaneously increases the effective differential input voltage range, and shifts the allowable common-mode input range. In this circuit, setting R<sub>1</sub> = R<sub>2</sub> and R<sub>3</sub> = R<sub>4</sub> maintains differential symmetry.

**Figure 4. Generalized Differential Range Expander Interface**

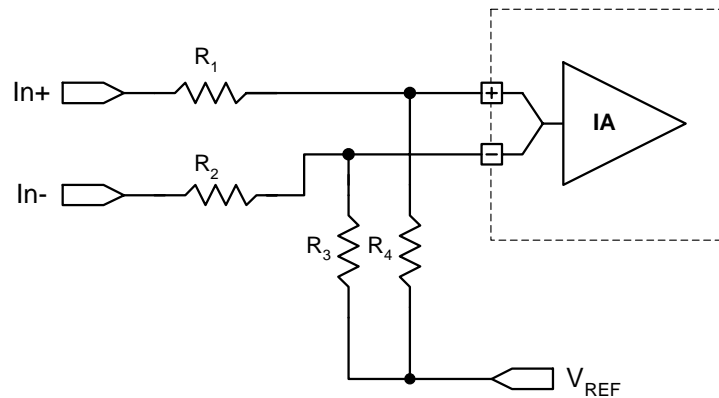

The differential attenuation of this input circuit is dependent on the resistor values only, and is given by:

$$A_V = \frac{R_3}{R_1 + R_3} \tag{1}$$

The degree to which this circuit attenuates shifts the common-mode value of the input signal is controlled by both the resistor values, and the value of the reference voltage to which it is terminated. By a suitable choice of termination voltage, this circuit can accommodate signals with a wide range of common-mode voltages. The common-mode voltage presented to the ispPAC input ( $V_{OCM}$ ) is related to the input common-mode voltage ( $V_{ICM}$ ) and the values of the resistors and reference voltage ( $V_{REF}$ ) by:

$$V_{OCM} = V_{REF} + (V_{ICM} - V_{REF}) \times \left( \frac{R_3}{R_1 + R_3} \right) \tag{2}$$

Alternatively, if one knows the value of  $V_{OCM}$ , one can derive  $V_{ICM}$  by rearranging a few terms, resulting in the following expression:

$$V_{ICM} = (V_{OCM} - V_{REF}) \left( \frac{R_1 + R_3}{R_3} \right) + V_{REF} \tag{3}$$

Equation 3 is useful in determining the allowable range for  $V_{ICM}$  for a given combination of attenuation network and ispPAC device. Note that the limited current sink/source capabilities of  $V_{REF}$  must be considered when choosing resistor values.

Figure 5 shows an example of how this technique can be used to accept an input signal with a  $\pm 10V$  differential range. In this case, the resistive network maps the  $\pm 10V$  signal down to the  $\pm 3V$  input range of an ispPAC10, with a +10V differential input resulting in a 2.97V differential being presented to the ispPAC input. By using equation 3 we can also determine that the acceptable input-referred common-mode range extends from approximately -2.5V to +7.5V.

Figure 5.  $\pm 10V$  Differential input

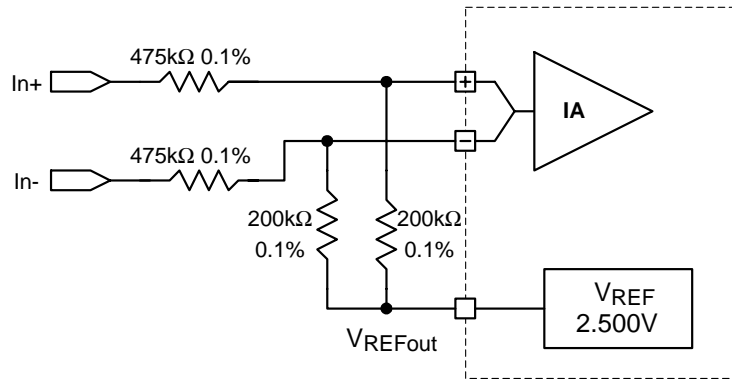
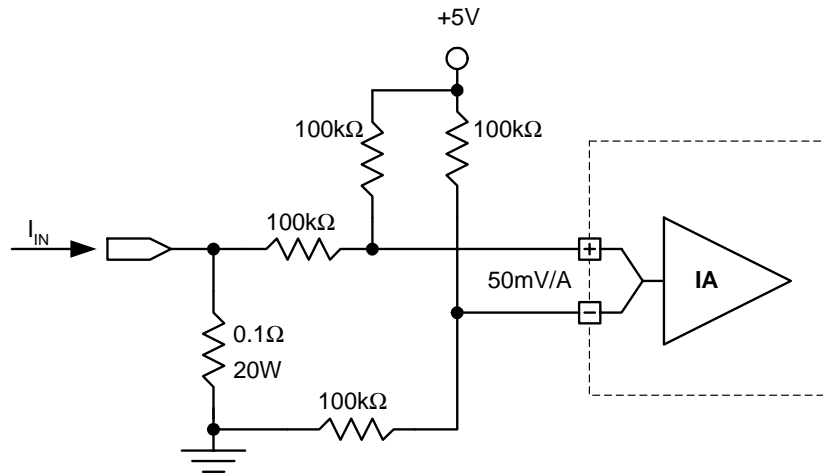

Figure 6 shows another example of this range extension technique, in this case extending the common-mode input range of an ispPAC10/20/80 input down to ground for use in a current sensor. In this circuit, the resistive network shown doubles the differential input range to  $\pm 6V$ . Terminating the network to  $+5V$  stretches the input common-mode range to cover a range of  $-3V$  to  $+3V$ . Although this circuit performs the same function as that of Figure 3 (using an ispPAC30), it provides an additional advantage of being able to measure voltages below ground. This extended range allows this circuit to measure negative as well as positive currents, whereas the circuit of Figure 3 is restricted to measuring positive currents (flowing into terminal) only.

Figure 6. Sensing Differential signals near ground with ispPAC10/20/80



Another difference between this circuit and that of Figure 3 is that the signal reaching the ispPAC input is attenuated, in this case by a factor of two, resulting in an input sensitivity of only  $50mV/A$  versus  $100mV/A$ . In a case such as this, where the signal magnitude is already small in relation to the ispPAC's input range, the IA can be used with a gain greater than one to increase the signal's amplitude.

To effectively use the range expansion circuits described above, it is important to match  $R_1$  with  $R_2$  and  $R_3$  with  $R_4$ . A mismatch between  $R_1$  and  $R_2$  or between  $R_3$  and  $R_4$  will result in a reduction in the system's common-mode rejection. In applications where common-mode rejection performance must be kept to a maximum, one should consider using 0.1% toleranced resistors.

### Interfacing to Single-ended Signal Sources

Although differential signaling offers many significant benefits in a design, most analog designs done today still use single-ended signals where system 'ground' is used as a global zero-volt reference. The differential inputs provided on ispPAC products provide more than enough flexibility to accommodate single-ended signals.

The simplest interfacing scenario is when the value of the single-ended signal falls within the common-mode range of the ispPAC input. In these cases, one just runs the signal into one terminal of the ispPAC's differential input pair (usually the positive one), and ties the other terminal to a suitable reference voltage, as shown in Figure 7. For ispPAC10/20/80 inputs, an input range of +1V to +4V can be accommodated. In the example shown in Figure 7a, the negative input terminal is tied to the ispPAC's 2.5V precision reference. This results in the external +1 to +4V input signal being mapped onto a -1.5V to +1.5V internal representation in the ispPAC device, as the signal value is determined by the *difference* in voltage at the input terminals.

**Figure 7. DC Coupling a Single-ended Signal**

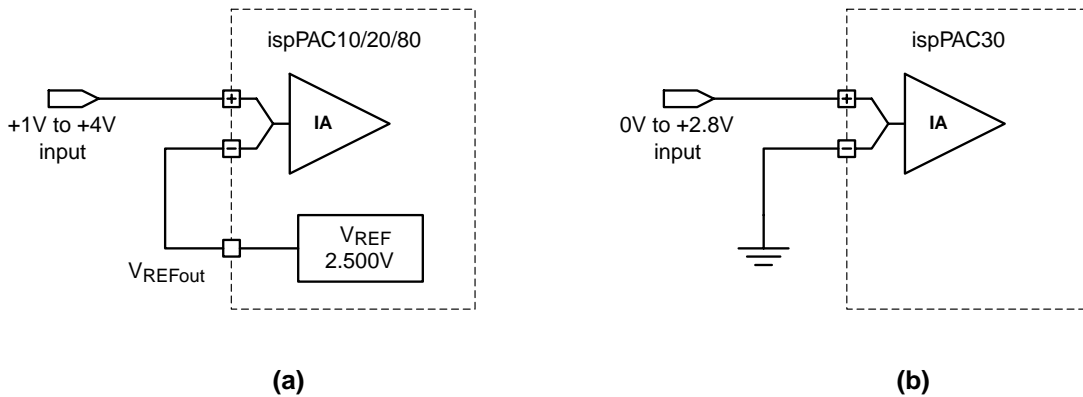

When using an ispPAC30 with a single-ended input (Figure 7b) one also ties the unused terminal to some reference voltage. Since the common-mode input range for the ispPAC30 includes ground, one can tie the unused input there. This results in an internal signal value which corresponds directly to the input signal voltage (e.g. a +1.67V input results in +1.67V of signal internally). When using an ispPAC30 in this manner, it will accommodate single-ended input signals ranging from 0V to +2.8V.

In systems operating from single +5V supplies, it is often desirable to be able to accommodate rail-to-rail signals, which range from ground to the positive supply voltage (+5V). Figure 8 shows interface circuits to allow ispPAC inputs to accept 0-5V signals.

**Figure 8. Interfacing to a 0-5V DC Signal**

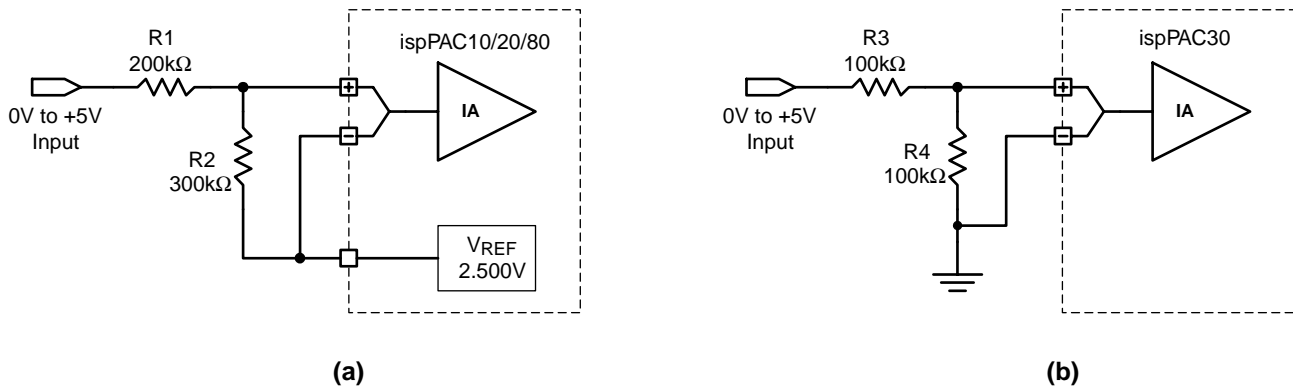

The circuit of Figure 8a allows an ispPAC10, 20 or 80 to accept 0-5V inputs, by mapping the 0-5V range to 1-4V at the device's input. The circuit of Figure 8b can be used with an ispPAC30, and maps the 0-5V input range to 0-2.5V at the device's input.

Because of the variety of applications in which analog circuitry is used, adjusting both the span and offset of a signal so that it can be compatible with a given input circuit is a common design problem. The problem is shown graphically in Figure 9, and consists of applying a suitable gain or attenuation to change the span, and also applying an offset to shift that span into a desired final range.

Figure 9. Adjustment of Span and Offset

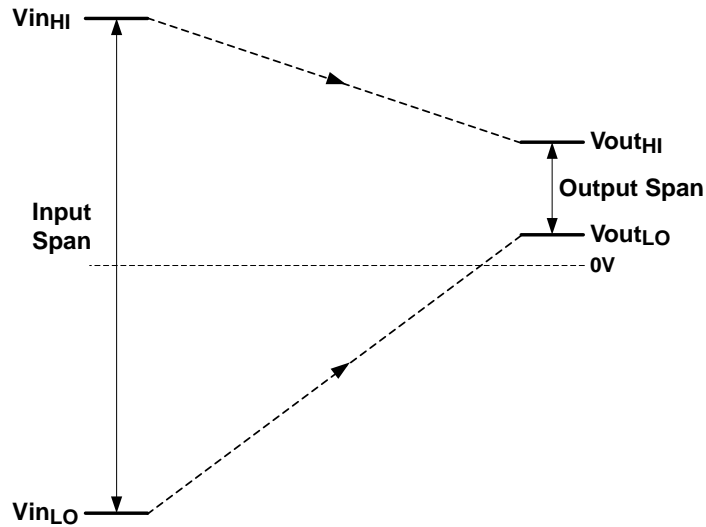

For cases where a larger range is compressed into a smaller range, resistive divider circuitry can often be used to perform the range adjustment. The three resistor circuit shown in Figure 10 can simultaneously perform both scale and offset adjustments.

Figure 10. Generalized Range-adjustment Network

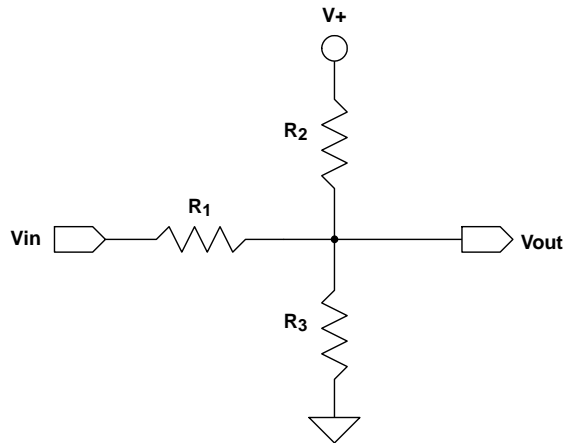

The design process for selecting appropriate resistor values is straightforward. To start, one needs to pick a value for  $R_1$ . For many applications, values of  $R_1$  from  $100\text{k}\Omega$  to  $10\text{M}\Omega$  will be suitable choices. The value of this resistor will strongly influence the circuit's input impedance. The input impedance of the whole network, assuming that the output is used to drive a high-impedance load such as an ispPAC input, can be calculated with Equation 4.

$$R_{IN} = R_1 \frac{R_2 R_3}{R_2 + R_3} \tag{4}$$

Next, one uses the Equations 5 and 6 to calculate the respective values of  $R_2$  and  $R_3$  from the voltage levels of the input and output spans ( $V_{inHI}$ ,  $V_{inLO}$ ,  $V_{outHI}$ ,  $V_{outLO}$ ),  $R_1$ , and the bias voltage  $V^+$  (typically 5V).

$$R_2 = R_1 \left( \frac{V^+ \cdot (V_{outLO} - V_{outHI})}{V_{outHI} \cdot V_{inLO} - V_{outLO} \cdot V_{inHI}} \right) \tag{5}$$

$$R_3 = R_1 \left( \frac{V^+ \cdot (V_{out_{LO}} - V_{out_{HI}})}{V_{in_{LO}} + V^+ - V_{out_{LO}} \cdot V^+ + V_{out_{HI}} \cdot V^+ + V_{out_{LO}} \cdot V_{in_{HI}} - V_{out_{HI}} \cdot V_{in_{LO}}} \right) \quad (6)$$

As an example, let's consider an interface to convert from a  $\pm 10V$  span to the +1 to +4V span optimal for an ispPAC10 input. For this example, let  $V^+ = 5V$ , and  $R_1 = 1 \text{ Meg } \Omega$ . The span variables are:

$$\begin{aligned} V_{in_{HI}} &= +10V & V_{in_{LO}} &= -10V \\ V_{out_{HI}} &= +4V & V_{out_{LO}} &= 1V \end{aligned}$$

This results in  $R_2 = 300K\Omega$ , and  $R_3 = 428K\Omega$ . Since standard resistors only come in fixed values, a good choice of stock 1% resistor values for this application might be to use  $302k\Omega$  for  $R_2$  and  $432k\Omega$  for  $R_3$ . For these particular choices of resistor values, a  $\pm 10V$  input span will compress down to an output range of 0.989 to 4.008 V, for nominal resistor values. Figure 10 shows the resulting circuit.

Figure 11.  $\pm 10V$  Single-ended Input for ispPAC10/20/80

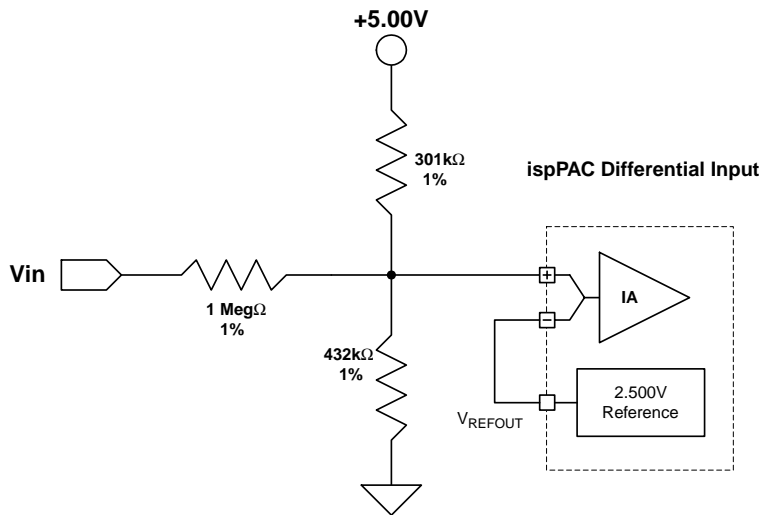

While this method of input scaling can accommodate many situations, there will be some span adjustments beyond its capabilities. In these cases, the design equations will indicate an unrealizable design with zero, infinite, or negative resistor values. One obvious case where this circuit won't work is when a small input span must be mapped onto a larger output span. In this situation active amplification is required and the passive network presented here will not provide the necessary transformation.

Frequently, one is only interested in the time-varying, or AC, component of a signal, and doesn't wish to propagate the DC value. An example of such an application is an audio power amplifier used to drive loudspeakers. The useful information in the audio signal is carried over a frequency range of 20-20kHz. The signal's DC bias level (average voltage) does not affect its audio content. In this case, the DC bias level should be zero, as a non-zero DC bias level results in power being wasted in the amplifier and speakers, and possible excessive heating in these devices.

Figure 12 shows an interface circuit that passes only the AC signal components of an incoming signal. This circuit is a first-order passive RC high-pass filter, and is often called an AC *coupling circuit*. Capacitor  $C_1$  blocks DC signal components, while  $R_1$  is used to re-reference the average value of the signal to  $V_{REF}$  (2.5V). Because the  $V_{REFOUT}$  terminal on ispPAC devices has limited current drive, it is important to use a resistor with a value greater than  $100K\Omega$  for  $R_1$ . The average value (DC bias level) of the signal appearing at the ispPAC's positive input terminal is  $V_{REF}$ , resulting in zero average differential signal. The purpose of  $R_L$  is to protect the input against any potentially high input currents in the event that a rapid voltage transition occurs at the input; this resistor should be specified on the basis of the maximum voltage levels anticipated at the input side of the capacitor. While this circuit is designed for use with an ispPAC10, 20 or 80, it can also be used with the ispPAC30 by tying  $R_1$  to an appropriate

voltage reference source. A 0.1μF capacitor is used in this circuit to provide a low AC impedance at the VREF output.

**Figure 12. 3V Peak-to-peak AC Coupling Circuit**

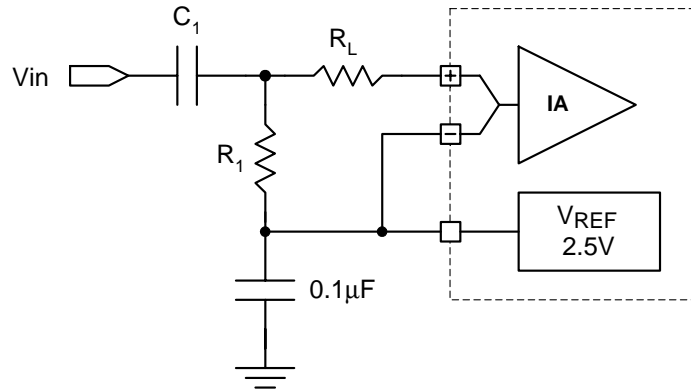

Because this circuit is a high-pass filter, it does not have a uniform response all the way down to DC, but has a -3dB corner frequency occurring at  $F_c = 1/2\pi R_1 C_1$ , with response gradually decreasing to zero at DC.

While the previous circuit allowed for a peak-to-peak input that was limited to the ispPAC’s input range, it is also possible to build AC coupling circuits that operate over much wider ranges. Figure 13 shows an example of an AC coupler that scales a 30V peak-to-peak signal to the 3V peak-to-peak input range of an ispPAC10,20 or 80 input.

**Figure 13. High Voltage Peak-to-peak AC Coupling Circuit**

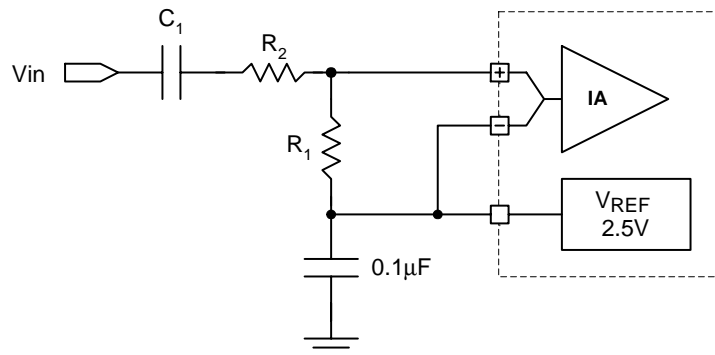

In this circuit,  $R_1$  and  $R_2$  form a voltage divider after the coupling capacitor, with a voltage gain of  $A_V = R_1/(R_1+R_2)$ . Because  $R_2$  provides current limiting, the  $R_L$  resistor used in the circuit of Figure 12 may be omitted. In this circuit, the high-pass corner frequency will be given by

$$F_c = \frac{1}{2\pi C_1 (R_1 + R_2)} \tag{7}$$

Again, in this circuit, the value of  $R_1$  should be 100kΩ or greater so as to not load down the on-chip reference.

## Conclusion

This application note has shown how Lattice ispPAC products can be used to meet numerous signal interfacing requirements. ispPAC products can accept inputs from both differential and single-ended sources, with signal magnitudes ranging from millivolts to tens of volts, when used with suitable input scaling networks, while still retaining all the benefits of in-system programmability.

## Technical Support Assistance

Hotline: 1-800-LATTICE (Domestic)  
1-408-826-6002 (International)  
e-mail: [ispPACs@latticesemi.com](mailto:ispPACs@latticesemi.com)