

Introduction

Power MOSFETs are increasingly being used to switch local power supplies on PCB assemblies. The Lattice ispPAC[®]-POWR1208 can be used in several ways to provide intelligent control of these devices for power supply sequencing, monitoring, and management applications. This application note describes a few of the ways in which the ispPAC-POWR1208 can be interfaced to common MOSFETs, and also some of the criteria for selecting suitable devices.

A few of the more common power-switch configurations for power MOSFETs are:

1. N-channel Positive Supply Switch
2. P-channel Positive Supply Switch
3. N-channel Negative Supply Switch

Each of these configurations has various applicability, advantages, and disadvantages, and will be individually discussed in the following sections.

N-Channel Positive Supply Switch

The ispPAC-POWR1208's high-voltage MOSFET drivers were designed specifically to drive N-channel MOSFETs used as positive supply switches (often called 'High-side switches'). Figure 1 shows a typical configuration.

Figure 1. N-Channel MOSFET Used as Positive Supply Switch

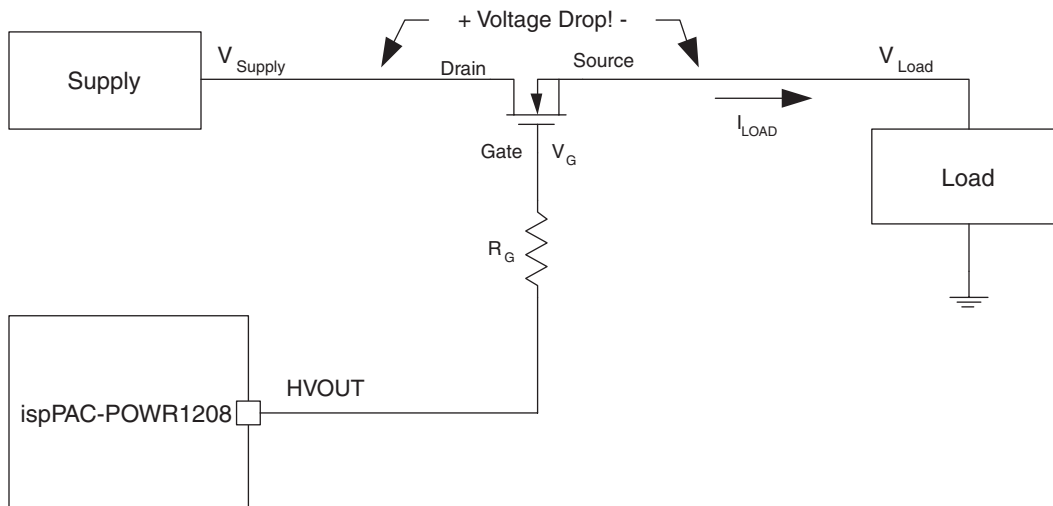

To turn on the MOSFET and connect the load to the power supply, the MOSFET's gate terminal must be raised positive *with respect to the MOSFET's source terminal*. For example, if the power supply provides 3.3V, and 3.3V is needed at the load, the MOSFET's gate terminal must be raised significantly above 3.3V, often as much as 5V to 8V higher. This may require that 8V to 11V be applied to the gate by the ispPAC-POWR1208. This is why you can't just drive the MOSFET from a standard PLD logic output. Exactly how much higher depends on the specifications of the particular MOSFET used. This is the primary reason for incorporating the HVOUT high-voltage drivers in the ispPAC-POWR1208 – they can provide a gate drive voltage as much as 7V higher than the ispPAC-POWR1208's supply rail. An additional advantage of using the ispPAC-POWR1208's high-voltage output is that their output current can be programmed to provide a controlled slew-rate voltage ramp at the MOSFET's gate. This has the effect of providing a soft-start for the load.

To reduce the possibility of RF oscillation, a gate resistor (R_G) is often inserted in series with the gate of the MOSFET power switch. This resistor should be placed physically close to the MOSFET gate terminal, and connected by as short a PCB trace as is feasible. An appropriate value for these gate resistors is highly dependent on both the characteristics of the MOSFET being used and the circumstances of the application, but will often be in the range of 10Ω to 100Ω .

Selecting an appropriate MOSFET is crucial to successfully implementing a power switch. Some of the major selection criteria include:

- Turn-on Voltage
- Drain-Source Breakdown Voltage
- Gate-Source Breakdown Voltage
- On-Resistance (R_{DSon})
- Maximum Current
- Package (Size)
- Cost

Turn-on voltage is one of the most important selection criteria. Many older types of MOSFETs, and those designed for switched-mode power supply and motion control applications can require a significant amount ($> 8-10V$) of gate-to-source drive. Newer devices with much lower gate-voltage requirements are now available, with devices which can be turned-on to a useful degree with as little as $1.8V$. These lower gate-drive devices are preferred for use with the ispPAC-POWR1208 for most power-switching applications.

Drain-to-source and gate-to-source breakdown voltages are also an important consideration. When switching power for logic supplies ($1.2V-5V$), drain-to-source breakdown voltage is not usually a problem, as most contemporary devices have breakdowns greater than $12V$.

Gate-to-source breakdown, however, is an issue which must be considered, especially as many suitable devices have low ($<10V$) ratings, and could be damaged by the ispPAC-POWR1208's output drivers if used inappropriately.

On resistance, maximum current, package size and cost must be traded off against each other for a successful design. In particular, MOSFETs with low on-resistances and high maximum current ratings tend to be more expensive than those with high on-resistances and low current ratings. Additionally, MOSFETs in smaller packages tend to have lower current ratings and higher on-resistances than those in larger packages. While over-specifying a device may make for an easy design, that design may not meet board-space or economic constraints.

For this application, some of the factors driving selection are:

1. How much current do I want to switch?
2. How much voltage drop is acceptable across the MOSFET
3. What is the voltage I am switching?

The cost of a given MOSFET correlates with its maximum current capacity, so there is some incentive to select a device with as low a current rating as will work in an application. Unfortunately, the current rating given in the data sheet refers to that which the MOSFET can handle before it is damaged, and not the amount it can switch with an arbitrarily low drain-to-source voltage drop (this voltage drop is illustrated in Figure 1) when operating at a given current level. For a current-switch, the acceptable voltage drop at operating current defines a maximum acceptable R_{DSon} value, which will tend to drive MOSFET selection more than maximum current ratings will.

The voltage being switched also impacts the selection process. Recall that in order to switch the N-channel MOSFET in Figure 1, the gate voltage must be higher than the voltage being switched, by at least enough to completely turn on the device. When the ispPAC-POWR1208 runs from a $3.3V$ supply, it can safely provide $\sim 10V$ of gate drive, so the MOSFET in this application must be completely turned on with $6.7V$ ($10V - 3.3V$ at the source). This will tend to drive selection to low-turn-on voltage devices.

Lattice Semiconductor

A concrete example will make it clear how these factors are translated into a MOSFET selection. Let us suppose that we are going to be switching a 2.5V power supply at 3A of load current. Also assume that the maximum voltage drop (V_{DS}) that can be tolerated across the MOSFET is 25mV, so that the load sees at least 2.475V.

From the desired voltage drop and the load current we can calculate a maximum MOSFET on-resistance:

$$R_{DSon} = \frac{V_{DS}}{I} = \frac{25mV}{3A} = 8.33m\Omega \quad (1)$$

Note that on-resistance is ALWAYS specified for a given amount of gate-to-source drive voltage. For a typical MOSFET, the higher the voltage you apply to the gate, the lower the on-resistance will be.

The next specifications are maximum current and maximum drain-to-source voltage. In many cases, where a low MOSFET drain-to-source voltage drop is needed, R_{DSon} will be the main selection criteria, rather than current, as MOSFETs with sufficiently low R_{DSon} 's will have much higher current ratings than necessary. For switching on-board power supplies for ICs, finding MOSFETs that meet the maximum voltage levels will be nearly trivial, as MOSFET drain-to-source breakdowns tend to be >12V, while the supplies being controlled typically range from +1.2V up to 5V. So for our example, we will need to find a MOSFET with the following characteristics:

- $R_{DSon} < 8 \text{ m}\Omega$
- $I_{Dmax} > 3 \text{ A}$
- $V_{DSmax} > 3V$

Finally, a small package would be nice, as this device is going to be taking up valuable board space next to a micro-processor. Table 1 shows several MOSFETs which meet the application requirements stated above.

Table 1. Example MOSFETs for use in Design Problem

Model	Manufacturer	R_{DSon} (m Ω)	I_{MAX} (A)	V_{DSmax} (V)	V_{GSmax} ($\pm V$)	Package
Si7858	Vishay	3	18	12	8	PowerPAK™ 1206
IRF6601	International Rectifier	5	26	20	20	DirectMOSFET™
FDS6064N3	Fairchild	4	23	20	8	SOIC-8

Note that the maximum gate-to-source voltage for two of these devices is only 8V. To use these devices with the ispPAC-POWR1208, you will need to set the ispPAC-POWR1208's maximum output voltage so as to ensure that the MOSFET's gate-to-source voltage remains below 8V at all times. It might also be a good idea to put a zener diode from the MOSFET's gate to ground to limit the maximum gate voltage. Also note that the maximum current ratings are considerably higher than the current we are planning on controlling. This is because in many applications, a drain-to-source voltage drop of a few hundred millivolts is acceptable, where in this application the voltage drop needs to be much lower. This results in the apparent overspecification we see here.

What if higher current is needed? The brute-force solution is to look for MOSFETs with lower R_{DSon} values. This approach becomes less effective as lower resistances are needed, and available devices become scarce. An alternative solution is to put MOSFETs in parallel. This lowers the effective on resistance by a factor of the number of MOSFETs used. For example, if we parallel three MOSFETs with 3 m Ω on resistances, we get an equivalent on resistance of 1 m Ω . This technique only works, however, when paralleling the same model of MOSFET - you can't mix and match MOSFETs of different types and expect good results.

P-Channel Positive Supply Switch

Another common way to switch a positive power supply is with P-channel MOSFETs, as shown in Figure 2.

Figure 2. P-Channel MOSFET used as a Positive Supply Switch

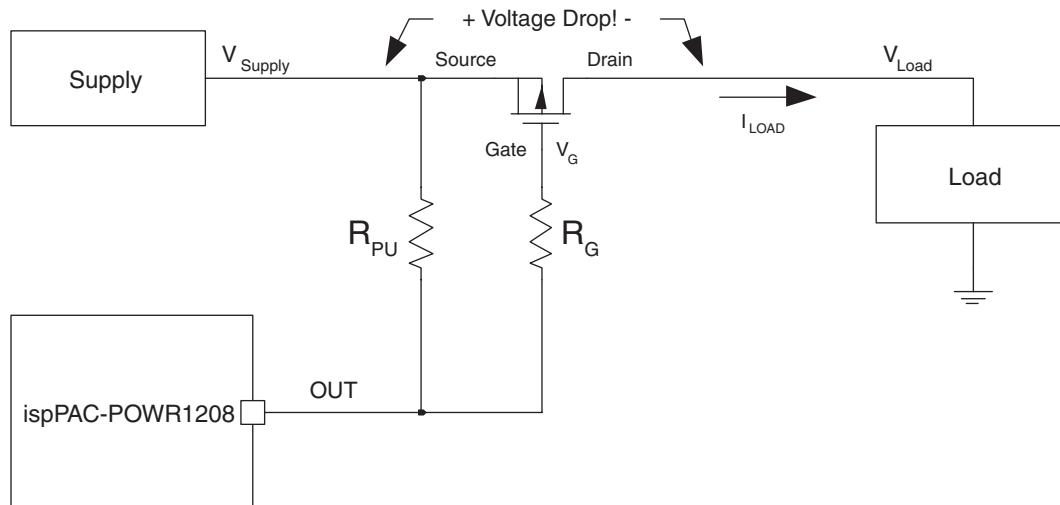

To turn on the MOSFET and connect the load to the power supply in this case, the MOSFET's gate terminal must be pulled negative with respect to the MOSFET's source terminal. Since the MOSFET's source terminal is connected to the power supply, this can often be accomplished by pulling the gate to ground, at least in cases where the power supply is at a voltage higher than the MOSFET's on-state gate-source voltage. This requirement will typically limit the use of this circuit technique to situations where the supply being switched is 2.5V or greater (at least for contemporary MOSFETs), and these cases will require the use of MOSFETs rated for 2.5V gate drive.

In this circuit, the ispPAC-POWR1208's outputs are used in the open-drain configuration. When the output goes LOW, it will pull the MOSFET's gate to ground and turn it on. The R_{PU} pull-up resistor pulls the gate up to the supply voltage and turns the MOSFET off when the output goes HIGH.

Note that all of the MOSFET considerations for current, on-resistance, breakdown and gate-drive voltages discussed above also apply to this circuit. Because this is a P-channel device, however, a negative gate-to-source voltage is required to turn the device on.

Because P-channel MOSFETs typically offer higher on-resistances and lower current ratings than N-channel devices of similar size and cost, this circuit configuration is primarily useful where lower levels of supply current and fast turn-on times are required. For most logic supply switching applications, N-channel devices with the ispPAC-POWR1208's high-voltage output drivers would be the preferred solution.

N-channel Negative Supply Switch

It is also possible to switch negative power supplies from the output of the ispPAC-POWR1208, as well as from standard 3.3V and 5V CMOS outputs. Figure 3 shows one circuit for doing so, using an N-channel MOSFET as a power switch.

Figure 3. N-Channel MOSFET Used as a Negative Supply Switch

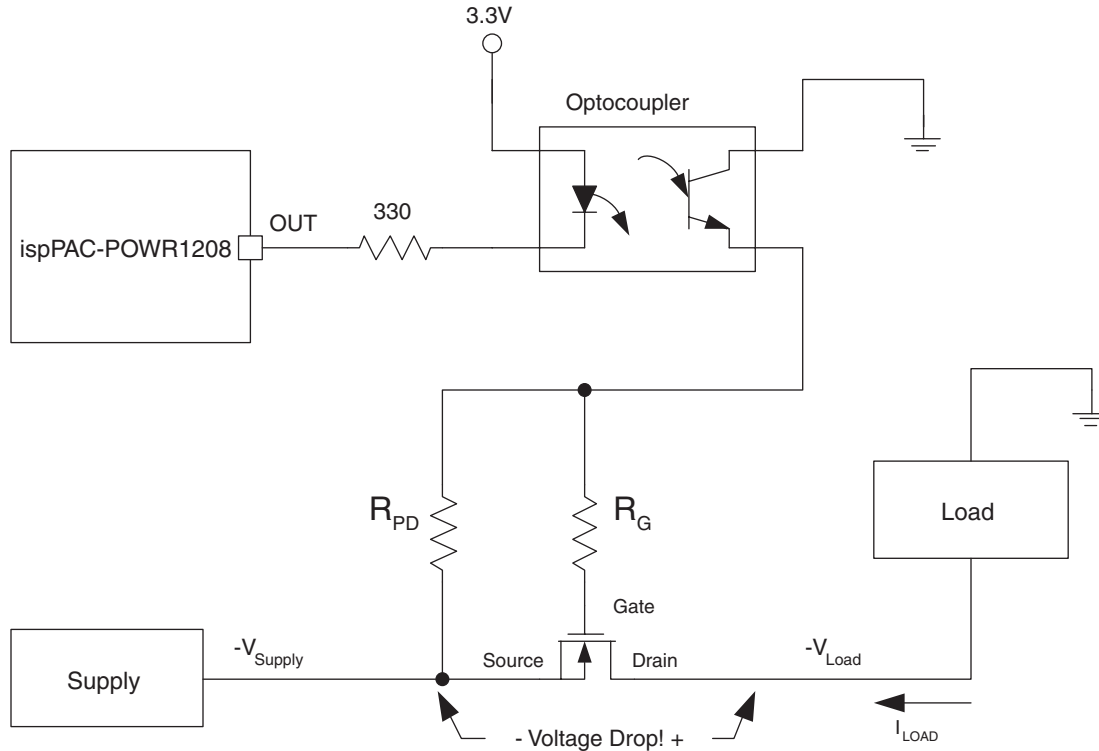

In this circuit, an optocoupler is used to provide level translation from the positive output levels of the ispPAC-POWR1208 to the negative voltage signals needed to drive the MOSFET. In this case, the ispPAC-POWR1208's open drain output is used. When the output goes low, the optocoupler is turned on, pulling the MOSFET's gate up to ground. Since the MOSFET's source is at the negative supply voltage, this creates a positive gate-to-source voltage and turns the MOSFET on. When the ispPAC-POWR1208 output goes high, the optocoupler is turned off, and the MOSFET's gate is pulled down to the negative supply voltage through R_{PD} .

In cases where a low value of negative supply is to be switched (e.g. $|V_S| < 2.5V$), 'ground' may not provide a high enough gate-to-source voltage to adequately turn on the MOSFET. In cases such as these, additional drive can be provided by connecting the optocoupler's collector output pin to a higher voltage such as 3.3V, instead of ground.

Example MOSFETs

Table 2 presents key characteristics of several MOSFETs which may be useful in power-supply switching applications. Because of the variety of applications requirements, we do not represent that any device in this table is suitable for a specific application. We also do not endorse any particular manufacturer. Device and supplier selection are complex issues which must be made in light of both the technical and business requirements of a particular application. This list has been provided solely to show a representative set of devices in a variety of packages which may be of potential use in the circuits described in this application note.

Table 2. Selected MOSFETS for Power Supply Switching Applications

Manufacturer	Model	Type	R _{DSon, 4.5V} (mΩ)	R _{DSon, 2.5V} (mΩ)	R _{DSon, 1.8V} (mΩ)	I _{MAX} (A)	V _{DSmax} (V)	V _{GSmax} (±V)	Package
Vishay	SUM110N03-03P	N	4			110	30	20	TO-263
	SUB85N02-03	N	3	3.4	3.8	85	20	8	TO-263
	Si7858DP	N	3	4		18	12	8	PowerPAK SO8
	Si7445DP	P	7.7	9.4	12.5	-12	-20	8	PowerPAK SO8
	Si6475DQ	P	11	13.5	17	-7.8	-12	8	TSSOP-8
	Si6473DQ	P	12.5	16	21.5	-6.2	-20	8	TSSOP-8
	Si6466DQ	N	14	21		6.3	20	12	TSSOP-8
	Si5475DC	P	31	41	54	-5.5	-12	8	ChipFET™ 1206-8
	Si5406DC	N	20	25		6.9	12	8	ChipFET 1206-8
	Si4838DY	N	3	4		17	12	8	SOIC-8
	Si4465DY	P	9	11	16	-10	-8	8	SOIC-8
	Si4423DY	P	7.5	9	11.5	-10	-20	8	SOIC-8
	Si3473DV	P	23	29	41	-5.9	-12	8	TSOP-6
	Si3460DV	N	27	32	38	5.1	20	8	TSOP-6
	Si2323DS	P	39	52	68	-3.7	-20	8	SOT-23
	Si2314EDS	N	33	40	51	3.7	20	12	SOT23
ON Semi	NTHS5404T1	N	30	45		5.2	20	12	ChipFET 1206-8
	NTHS5445T1	P	35	47	62	5.2	-8	8	ChipFET 1206-8
	NTQS6463	P	20	27		-5.5	-20	12	TSSOP-8
	NTTS2P02R2	P	90			-2.4	-20	8	Micro-8
	MBT50P03HDL	P	20 @ 5Vgs			-50	-30	15	D2PAK
	NTMS4N01R2	N	40			5.9	20	10	SOIC-8
	HDTMOS3E	P	14	20		-10	-20	12	SOIC-8
NTMS4P01R2	P	45			-6	-12	10	SOIC-8	

Table 2. Selected MOSFETS for Power Supply Switching Applications (Continued)

Manufacturer	Model	Type	R _{DSon} , 4.5V (mΩ)	R _{DSon} , 2.5V (mΩ)	R _{DSon} , 1.8V (mΩ)	I _{MAX} (A)	V _{DSmax} (V)	V _{GSmax} (±V)	Package
International Rectifier	IRLMS2002	N	30	45		5.2	20	12	Micro6™
	IRLMS4502	P	42	75		5.5	-12	12	Micro6
	IRLML6401	P	50	85	125	-4.3	-12	8	SOT-23
	IRLM2502	N	45	80		4.2	20	12	SOT-23
	IRL3716S	N	4.8			110	20	20	D2PAK
	IRL3402S	N	10			85	20	10	D2PAK
	IRF7701	P	11	15	22	-10	-12	8	TSSOP-8
	IRF7459	N	11	22 @ 2.8Vgs		12	20	12	SOIC-8
	IRF7410	P	7	9	13	-11.5	-12	8	SOIC-8
	IRF7401	N	22	30 @ 2.7Vgs		8.7	20	12	SOIC-8
	IRF6601	N	5			26	20	20	DirectFET
	IRF3716S	N	10.5	22 @ 2.8Vgs		77	20	12	D2PAK
Fairchild	FDS6679	P	13			-13	-30	25	SOIC-8
	FDS6574A	N	6	7	9	16	20	8	SOIC-8
	FDS6162N7	N	3.5	5		23	20	12	SOIC-8
	FDS6064N3	N	4	5	7	23	20	8	SOIC-8
	FDS4465	P	8.5	10.5	14	-13.5	-20	8	SOIC-8
	FDR844P	P	11	14	20	-10	-20	8	SOIC-8
	FDN339AN	N	35	50		3	20	8	Super-SOT™-3
	FDD3706	N	11	16		50	20	12	DPAK
	FDC637AN	N	24	32		6.2	20	8	SuperSOT-6

This table provides the following information:

1. Manufacturer
2. Model number
3. Type (N-channel or P-channel)
4. R_{DSon} at various voltages (4.5, 2.5, 1.8)
5. I_{MAX} (maximum continuous drain current)
6. V_{DSmax} (maximum drain-to-source voltage)
7. V_{GSmax} (maximum gate-to-source voltage)
8. Package type (we only included SMD parts in this selection)

Additional Resources

Successfully choosing a MOSFET for a particular application takes more expertise than we can impart in this application note. For detailed advice we suggest you refer to the information and applications resources provided by MOSFET manufacturers. A few manufacturers of these devices include:

Fairchild Semiconductor: www.fairchildsemi.com

International Rectifier: www.irf.com

On Semiconductor: www.onsemi.com

Vishay-Siliconix: www.siliconix.com

Related Literature

- *ispPAC-POWR1208 Data Sheet*
- AN6043, *Using the ispPAC-POWR1208 MOSFET Driver Outputs*

Technical Support Assistance

Hotline: 1-800-LATTICE (Domestic)
1-408-826-6002 (International)
e-mail: ispPACs@latticesemi.com
Internet: www.latticesemi.com