

Features

- **Monitor and Control Multiple Power Supplies**
 - Simultaneously monitors up to 10 power supplies
 - Provides up to 14 output control signals
 - Programmable digital and analog circuitry
- **Embedded PLD for Sequence Control**
 - 24-macrocell CPLD implements both state machines and combinatorial logic functions
- **Embedded Programmable Timers**
 - Four independent timers
 - 32µs to 2 second intervals for timing sequences
- **Analog Input Monitoring**
 - 10 independent analog monitor inputs
 - Two programmable threshold comparators per analog input
 - Hardware window comparison
 - 10-bit ADC for I²C monitoring (ispPAC-POWR1014A only)
- **High-Voltage FET Drivers**
 - Power supply ramp up/down control
 - Programmable current and voltage output
 - Independently configurable for FET control or digital output
- **2-Wire (I²C/SMBus[™] Compatible) Interface**
 - Comparator status monitor
 - ADC readout
 - Direct control of inputs and outputs
 - Power sequence control
 - Only available with ispPAC-POWR1014A
- **3.3V Operation, Wide Supply Range 2.8V to 3.96V**
 - Industrial temperature range: -40°C to +85°C
 - 48-pin TQFP package, lead-free option
- **Multi-Function JTAG Interface**
 - In-system programming
 - Access to all I²C registers
 - Direct input control

Application Block Diagram

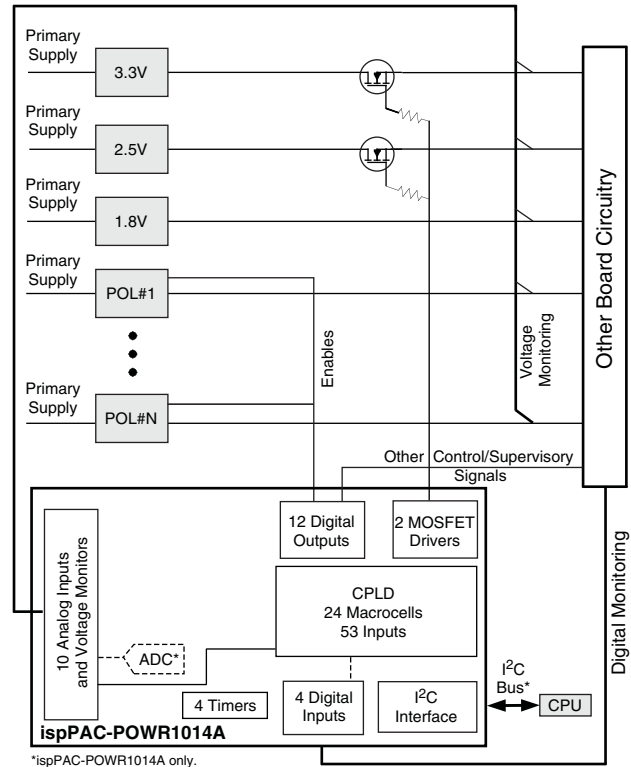

Description

Lattice's Power Manager II ispPAC-POWR1014/A is a general-purpose power-supply monitor and sequence controller, incorporating both in-system programmable logic and in-system programmable analog functions implemented in non-volatile E²CMOS[®] technology. The ispPAC-POWR1014/A device provides 10 independent analog input channels to monitor up to 10 power supply test points. Each of these input channels has two independently programmable comparators to support both high/low and in-bounds/out-of-bounds (window-compare) monitor functions. Four general-purpose digital inputs are also provided for miscellaneous control functions.

The ispPAC-POWR1014/A provides 14 open-drain digital outputs that can be used for controlling DC-DC converters, low-drop-out regulators (LDOs) and optocouplers, as well as for supervisory and general-purpose logic interface functions. Two of these outputs (HVOUT1-HVOUT2) may be configured as high-voltage

MOSFET drivers. In high-voltage mode these outputs can provide up to 12V for driving the gates of n-channel MOSFETs so that they can be used as high-side power switches controlling the supplies with a programmable ramp rate for both ramp up and ramp down.

The ispPAC-POWR1014/A incorporates a 24-macrocell CPLD that can be used to implement complex state machine sequencing for the control of multiple power supplies as well as combinatorial logic functions. The status of all of the comparators on the analog input channels as well as the general purpose digital inputs are used as inputs by the CPLD array, and all digital outputs may be controlled by the CPLD. Four independently programmable timers can create delays and time-outs ranging from 32µs to 2 seconds. The CPLD is programmed using Logi-Builder™, an easy-to-learn language integrated into the PAC-Designer® software. Control sequences are written to monitor the status of any of the analog input channel comparators or the digital inputs.

The on-chip 10-bit A/D converter is used to monitor the V_{MON} voltage through the I²C bus or JTAG interface of the ispPAC-POWR1014A device.

The I²C bus/SMBus interface allows an external microcontroller to measure the voltages connected to the V_{MON} inputs, read back the status of each of the V_{MON} comparator and PLD outputs, control logic signals IN2 to IN4 and control the output pins (ispPAC-POWR1014A only). The JTAG interface can be used to read out all I²C registers during manufacturing.

Figure 2-1. ispPAC-POWR1014/A Block Diagram

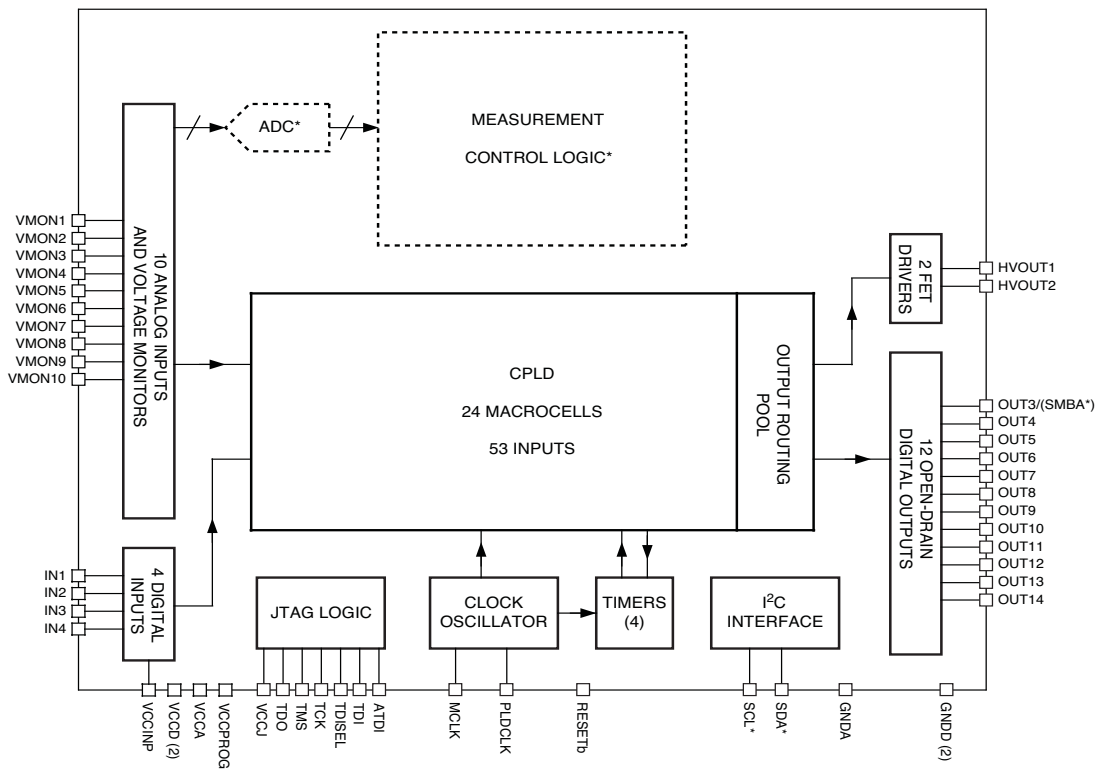

*ispPAC-POWR1014A only.

Pin Descriptions

Number	Name	Pin Type	Voltage Range	Description
44	IN1	Digital Input	VCCINP ^{1,2}	PLD Logic Input 1 Registered by MCLK
46	IN2	Digital Input	VCCINP ^{1,3}	PLD Logic Input 2 Registered by MCLK
47	IN3	Digital Input	VCCINP ^{1,3}	PLD Logic Input 3 Registered by MCLK
48	IN4	Digital Input	VCCINP ^{1,3}	PLD Logic Input 4 Registered by MCLK
25	VMON1	Analog Input	-0.3V to 5.87V	Voltage Monitor 1 Input
26	VMON2	Analog Input	-0.3V to 5.87V	Voltage Monitor 2 Input
27	VMON3	Analog Input	-0.3V to 5.87V	Voltage Monitor 3 Input
28	VMON4	Analog Input	-0.3V to 5.87V	Voltage Monitor 4 Input
32	VMON5	Analog Input	-0.3V to 5.87V	Voltage Monitor 5 Input
33	VMON6	Analog Input	-0.3V to 5.87V	Voltage Monitor 6 Input
34	VMON7	Analog Input	-0.3V to 5.87V	Voltage Monitor 7 Input
35	VMON8	Analog Input	-0.3V to 5.87V	Voltage Monitor 8 Input
36	VMON9	Analog Input	-0.3V to 5.87V	Voltage Monitor 9 Input
37	VMON10	Analog Input	-0.3V to 5.87V	Voltage Monitor 10 Input
7, 31	GNDD ⁴	Ground	Ground	Digital Ground
30	GNDA ⁴	Ground	Ground	Analog Ground
41, 23	VCCD ⁵	Power	2.8V to 3.96V	Core VCC, Main Power Supply
29	VCCA ⁵	Power	2.8V to 3.96V	Analog Power Supply
45	VCCINP	Power	2.25V to 5.5V	VCC for IN[1:4] Inputs
20	VCCJ	Power	2.25V to 3.6V	VCC for JTAG Logic Interface Pins
24	VCCPROG ⁹	Power	3.0V to 3.6V	VCC for E ² Programming Only when the Device is NOT Powered by V _{CCD} and V _{CCA} , otherwise, must be floating.
15	HVOUT1	Open Drain Output ⁶	0V to 13V	Open-Drain Output 1
		Current Source/Sink	12.5μA to 100μA Source 100μA to 3000μA Sink	High-voltage FET Gate Driver 1
14	HVOUT2	Open Drain Output ⁶	0V to 13V	Open-Drain Output 2
		Current Source/Sink	12.5μA to 100μA Source 100μA to 3000μA Sink	High-voltage FET Gate Driver 2
13	SMBA_OUT3	Open Drain Output ⁶	0V to 5.5V	Open-Drain Output 3, (SMBUS Alert Active Low, ispPAC-POWR1014A only).
12	OUT4	Open Drain Output ⁶	0V to 5.5V	Open-Drain Output 4
11	OUT5	Open Drain Output ⁶	0V to 5.5V	Open-Drain Output 5
10	OUT6	Open Drain Output ⁶	0V to 5.5V	Open-Drain Output 6
9	OUT7	Open Drain Output ⁶	0V to 5.5V	Open-Drain Output 7
8	OUT8	Open Drain Output ⁶	0V to 5.5V	Open-Drain Output 8
6	OUT9	Open Drain Output ⁶	0V to 5.5V	Open-Drain Output 9
5	OUT10	Open Drain Output ⁶	0V to 5.5V	Open-Drain Output 10
4	OUT11	Open Drain Output ⁶	0V to 5.5V	Open-Drain Output 11
3	OUT12	Open Drain Output ⁶	0V to 5.5V	Open-Drain Output 12
2	OUT13	Open Drain Output ⁶	0V to 5.5V	Open-Drain Output 13
1	OUT14	Open Drain Output ⁶	0V to 5.5V	Open-Drain Output 14
40	RESETb ⁷	Digital I/O	0V to 3.96V	Device Reset (Active Low) Pin internally pulled up.

Pin Descriptions (Cont.)

Number	Name	Pin Type	Voltage Range	Description
42	PLDCLK	Digital Output	0V to 3.96V	250kHz PLD Clock Output (Tristate), CMOS Output Pin internally pulled up.
43	MCLK	Digital I/O	0V to 3.96V	8MHz Clock I/O (Tristate), CMOS Drive. Pin internally pulled up.
21	TDO	Digital Output	0V to 5.5V	JTAG Test Data Out
22	TCK	Digital Input	0V to 5.5V	JTAG Test Clock Input
16	TMS	Digital Input	0V to 5.5V	JTAG Test Mode Select Pin internally pulled up.
18	TDI	Digital Input	0V to 5.5V	JTAG Test Data In, TDISEL pin = 1. Pin internally pulled up.
17	ATDI	Digital Input	0V to 5.5V	JTAG Test Data In (Alternate), TDISEL Pin = 0. Pin internally pulled up.
19	TDISEL	Digital Input	0V to 5.5V	Select TDI/ATDI Input Pin internally pulled up.
39	SCL ^{9, 11}	Digital Input	0V to 5.5V	I ² C Serial Clock Input (ispPAC-POWR1014A Only)
38	SDA ^{9, 11}	Digital I/O	0V to 5.5V	I ² C Serial Data, Bi-directional Pin, Open Drain (ispPAC-POWR1014A Only)

- [IN1...IN4] are inputs to the PLD. The thresholds for these pins are referenced by the voltage on VCCINP. Unused INx inputs should be tied to GNDD.
- IN1 pin can also be controlled through JTAG interface.
- [IN2..IN4] can also be controlled through I²C/SMBus interface (ispPAC-POWR1014A only).
- GNDA and GNDD pins must be connected together on the circuit board.
- VCCD and VCCA pins must be connected together on the circuit board.
- Open-drain outputs require an external pull-up resistor to a supply.
- The RESETb pin should only be used for cascading two or more ispPAC-POWR1014/A devices.
- These pins should be connected to GNDD (ispPAC-POWR1014 only).
- The VCCPROG pin MUST be left floating when V_{CCD} and V_{CCA} are powered.
- SCL should be tied high and SDA is don't care when I²C registers are accessed through the JTAG interface (ispPAC-POWR1014A only).

Absolute Maximum Ratings

Absolute maximum ratings are shown in the table below. Stresses beyond those listed may cause permanent damage to the device. Functional operation of the device at these or any other conditions beyond those indicated in the recommended operating conditions of this specification is not implied.

Symbol	Parameter	Conditions	Min.	Max.	Units
V _{CCD}	Core supply		-0.5	4.5	V
V _{CCA}	Analog supply		-0.5	4.5	V
V _{CCINP}	Digital input supply (IN[1:4])		-0.5	6	V
V _{CCJ}	JTAG logic supply		-0.5	6	V
V _{CCPROG}	Alternate E ² programming supply		-0.5	4	V
V _{IN}	Digital input voltage (all digital I/O pins)		-0.5	6	V
V _{MON}	V _{MON} input voltage		-0.5	6	V
V _{TRI}	Voltage applied to tri-stated pins	HVOUT[1:2]	-0.5	13.3	V
		OUT[3:14]	-0.5	6	V
I _{SINKMAXTOTAL}	Maximum sink current on any output			23	mA
T _S	Storage temperature		-65	150	°C
T _A	Ambient temperature		-65	125	°C

Recommended Operating Conditions

Symbol	Parameter	Conditions	Min.	Max.	Units
V _{CCD} , V _{CCA}	Core supply voltage at pin		2.8	3.96	V
V _{CCINP}	Digital input supply for IN[1:4] at pin		2.25	5.5	V
V _{CCJ}	JTAG logic supply voltage at pin		2.25	3.6	V
V _{CCPROG}	Alternate E ² programming supply at pin	V _{CCD} and V _{CCA} powered	No connect Must be left floating		V
		V _{CCD} and V _{CCA} not powered	3.0	3.6	V
V _{IN}	Input voltage at digital input pins		-0.3	5.5	V
V _{MON}	Input voltage at V _{MON} pins		-0.3	5.9	V
V _{OUT}	Open-drain output voltage	OUT[3:14] pins	-0.3	5.5	V
		HVOUT[1:2] pins in open-drain mode	-0.3	13.0	V
T _{APROG}	Ambient temperature during programming		-40	85	°C
T _A	Ambient temperature	Power applied	-40	85	°C

Analog Specifications

Symbol	Parameter	Conditions	Min.	Typ.	Max.	Units
I _{CC} ¹	Supply current				20	mA
I _{CCINP}	Supply current				5	mA
I _{CCJ}	Supply current				1	mA
I _{CCPROG}	Supply current	During programming cycle			20	mA

1. Includes currents on V_{CCD} and V_{CCA} supplies.

Voltage Monitors

Symbol	Parameter	Conditions	Min.	Typ.	Max.	Units
R_{IN}	Input resistance		55	65	75	$k\Omega$
C_{IN}	Input capacitance			8		pF
V_{MON} Range	Programmable trip-point range		0.075		5.867	V
V_Z Sense	Near-ground sense threshold		70	75	80	mV
V_{MON} Accuracy	Absolute accuracy of any trip-point ¹			0.3	0.9	%
HYST	Hysteresis of any trip-point (relative to setting)			1		%

1. Guaranteed by characterization across V_{CCA} range, operating temperature, process.

High Voltage FET Drivers

Symbol	Parameter	Conditions	Min.	Typ.	Max.	Units
V_{PP}	Gate driver output voltage	12V setting ¹	11.5	12	12.5	V
		10V setting	9.6	10	10.4	
		8V setting	7.7	8	8.3	
		6V setting	5.8	6	6.2	
I_{OUTSRC}	Gate driver source current (HIGH state)	Four settings in software		12.5		μA
				25		
				50		
				100		
$I_{OUTSINK}$	Gate driver sink current (LOW state)	FAST OFF mode	2000	3000		μA
		Controlled ramp settings		100		
				250		
			500			

1. 12V setting only available on ispPAC-POWR1014-02 and ispPAC-POWR1014A-02.

ADC Characteristics¹

Symbol	Parameter	Conditions	Min.	Typ.	Max.	Units
	ADC resolution			10		Bits
T _{CONVERT}	Conversion time	Time from I ² C request			100	μs
V _{IN}	Input range full scale	Programmable attenuator = 1	0		2.048	V
		Programmable attenuator = 3	0		5.9 ²	V
ADC Step Size	LSB	Programmable attenuator = 1		2		mV
		Programmable attenuator = 3		6		mV
E _{attenuator}	Error due to attenuator	Programmable attenuator = 3		+/- 0.1		%

1. ispPAC-POWR1014A only.

2. Maximum voltage is limited by V_{MONX} pin (theoretical maximum is 6.144V).

ADC Error Budget Across Entire Operating Temperature Range¹

Symbol	Parameter	Conditions	Min.	Typ.	Max.	Units
T _{ADC Error}	Total Measurement Error at Any Voltage ²	Measurement Range 600 mV - 2.048V, Attenuator =1	-8	+/-4	8	mV

1. ispPAC-POWR1014A only.

2. Total error, guaranteed by characterization, includes INL, DNL, Gain, Offset, and PSR specs of the ADC.

Power-On Reset

Symbol	Parameter	Conditions	Min.	Typ.	Max.	Units
T _{RST}	Delay from V _{TH} to start-up state				100	μs
T _{START}	Delay from RESETb HIGH to PLDCLK rising edge			5	10	μs
T _{GOOD}	Power-on reset to valid V _{MON} comparator output and AGOOD is true				500	μs
T _{BRO}	Minimum duration brown out required to trigger RESETb		1		5	μs
T _{POR}	Delay from brown out to reset state.				11	μs
V _{TL}	Threshold below which RESETb is LOW ¹				2.3	V
V _{TH}	Threshold above which RESETb is HIGH ¹		2.7			V
V _T	Threshold above which RESETb is valid ¹		0.8			V
C _L	Capacitive load on RESETb for master/slave operation				200	pF

1. Corresponds to VCCA and VCCD supply voltages.

Figure 2-2. ispPAC-POWR1014/A Power-On Reset

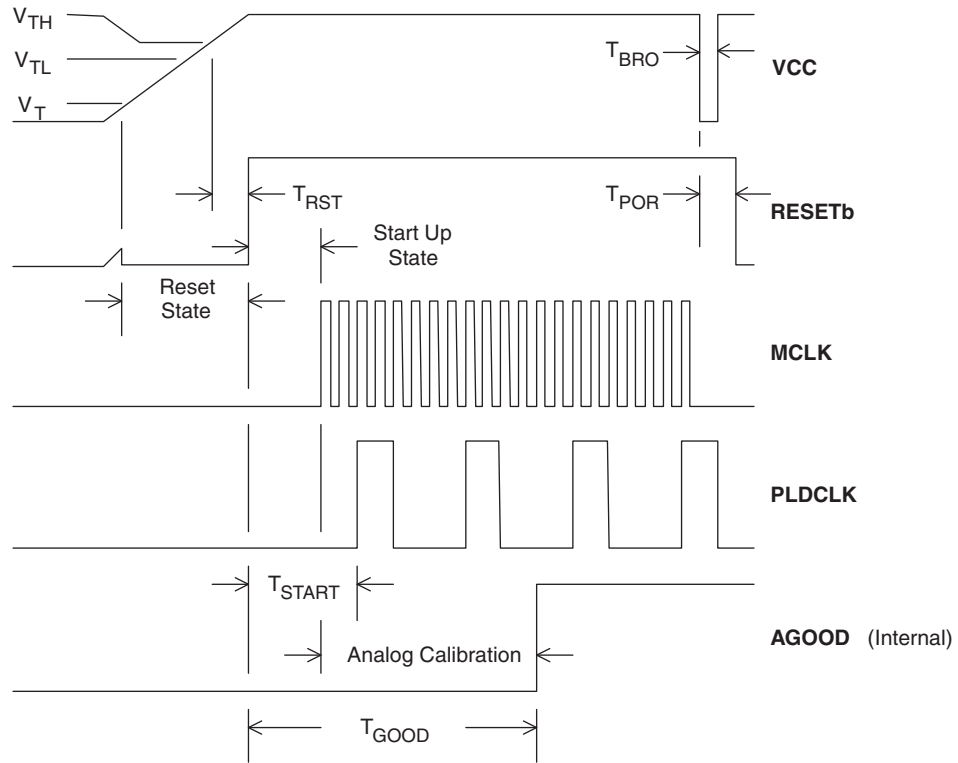

AC/Transient Characteristics

Over Recommended Operating Conditions

Symbol	Parameter	Conditions	Min.	Typ.	Max.	Units
Voltage Monitors						
t_{PD16}	Propagation delay input to output glitch filter OFF			16		μ s
t_{PD64}	Propagation delay input to output glitch filter ON			64		μ s
Oscillators						
f_{CLK}	Internal master clock frequency (MCLK)		7.6	8	8.4	MHz
f_{CLKEXT}	Externally applied master clock (MCLK)		7.2		8.8	MHz
f_{PLDCLK}	PLDCLK output frequency	$f_{CLK} = 8\text{MHz}$		250		kHz
Timers						
Timeout Range	Range of programmable timers (128 steps)	$f_{CLK} = 8\text{MHz}$	0.032		1966	ms
Resolution	Spacing between available adjacent timer intervals				13	%
Accuracy	Timer accuracy	$f_{CLK} = 8\text{MHz}$	-6.67		-12.5	%

Digital Specifications

Over Recommended Operating Conditions

Symbol	Parameter	Conditions	Min.	Typ.	Max.	Units
I_{IL}, I_{IH}	Input leakage, no pull-up/pull-down				+/-10	μA
$I_{OH-HVOUT}$	Output leakage current	HVOUT[1:2] in open drain mode and pulled up to 10V		35	60	μA
		HVOUT[1:2] in open drain mode and pulled up to 13V		35	100	μA
I_{PU}	Input pull-up current (TMS, TDI, TDISEL, ATDI, MCLK, PLDCLK, RESETb)			70		μA
V_{IL}	Voltage input, logic low ¹	TDI, TMS, ATDI, TDISEL, 3.3V supply			0.8	V
		TDI, TMS, ATDI, TDISEL, 2.5V supply			0.7	
		SCL, SDA			30% V_{CCD}	
		IN[1:4]			30% V_{CCINP}	
V_{IH}	Voltage input, logic high ¹	TDI, TMS, ATDI, TDISEL, 3.3V supply	2.0			V
		TDI, TMS, ATDI, TDISEL, 2.5V supply	1.7			
		SCL, SDA	70% V_{CCD}		V_{CCD}	
		IN[1:4]	70% V_{CCINP}		V_{CCINP}	
V_{OL}	HVOUT[1:2] (open drain mode),	$I_{SINK} = 10mA$			0.8	V
	OUT[3:14]	$I_{SINK} = 20mA$			0.8	
	TDO, MCLK, PLDCLK, SDA	$I_{SINK} = 4mA$			0.4	
V_{OH}	TDO, MCLK, PLDCLK	$I_{SRC} = 4mA$			$V_{CCD} - 0.4$	V
$I_{SINKTOTAL}^2$	All digital outputs				67	mA

1. IN[1:4] referenced to V_{CCINP} ; TDO, TDI, TMS, ATDI, TDISEL referenced to V_{CCJ} ; SCL, SDA referenced to V_{CCD} .

2. Sum of maximum current sink from all digital outputs combined. Reliable operation is not guaranteed if this value is exceeded.

I²C Port Characteristics¹

Symbol	Definition	100KHz		400KHz		Units
		Min.	Max.	Min.	Max.	
F _{I²C}	I ² C clock/data rate		100 ²		400 ²	KHz
T _{SU;STA}	After start	4.7		0.6		us
T _{HD;STA}	After start	4		0.6		us
T _{SU;DAT}	Data setup	250		100		ns
T _{SU;STO}	Stop setup	4		0.6		us
T _{HD;DAT}	Data hold; SCL= Vih_min = 2.1V	15	3.45	15	0.9	ns
T _{LOW}	Clock low period	4.7	10	1.3	10	us
T _{HIGH}	Clock high period	4		0.6		us
T _F	Fall time; 2.25V to 0.65V		300		300	ns
T _R	Rise time; 0.65V to 2.25V		1000		300	ns
T _{TIMEOUT}	Detect clock low timeout	25	35	25	35	ms
T _{POR}	Device must be operational after power-on reset	500		500		ms
T _{BUF}	Bus free time between stop and start condition	4.7		1.3		us

1. Applies to ispPAC-POWR1014A only.
2. If F_{I²C} is less than 50kHz, then the ADC DONE status bit is not guaranteed to be set after a valid conversion request is completed. In this case, waiting for the T_{CONVERT} minimum time after a convert request is made is the only way to guarantee a valid conversion is ready for readout. When F_{I²C} is greater than 50kHz, ADC conversion complete is ensured by waiting for the DONE status bit.

Timing for JTAG Operations

Symbol	Parameter	Conditions	Min.	Typ.	Max.	Units
t_{SPEN}	Program enable delay time		10	—	—	μs
t_{SPDIS}	Program disable delay time		30	—	—	μs
t_{HVDIS}	High voltage discharge time, program		30	—	—	μs
t_{HVDIS}	High voltage discharge time, erase		200	—	—	μs
t_{CEN}	Falling edge of TCK to TDO active		—	—	10	ns
t_{CDIS}	Falling edge of TCK to TDO disable		—	—	10	ns
t_{SU1}	Setup time		5	—	—	ns
t_{H}	Hold time		10	—	—	ns
t_{CKH}	TCK clock pulse width, high		20	—	—	ns
t_{CKL}	TCK clock pulse width, low		20	—	—	ns
f_{MAX}	Maximum TCK clock frequency		—	—	25	MHz
t_{CO}	Falling edge of TCK to valid output		—	—	10	ns
t_{PWV}	Verify pulse width		30	—	—	μs
t_{PWP}	Programming pulse width		20	—	—	ms

Figure 2-3. Erase (User Erase or Erase All) Timing Diagram

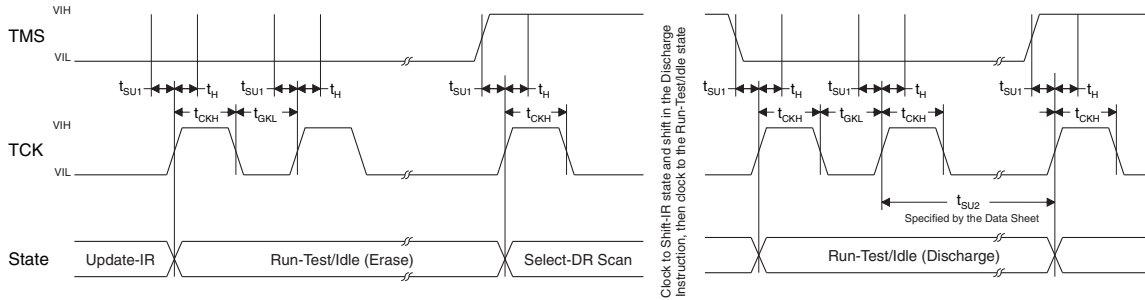

Figure 2-4. Programming Timing Diagram

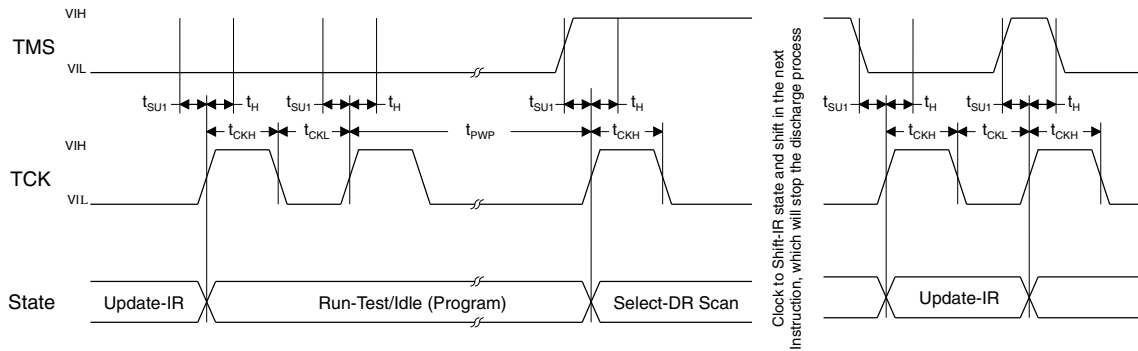

Figure 2-5. Verify Timing Diagram

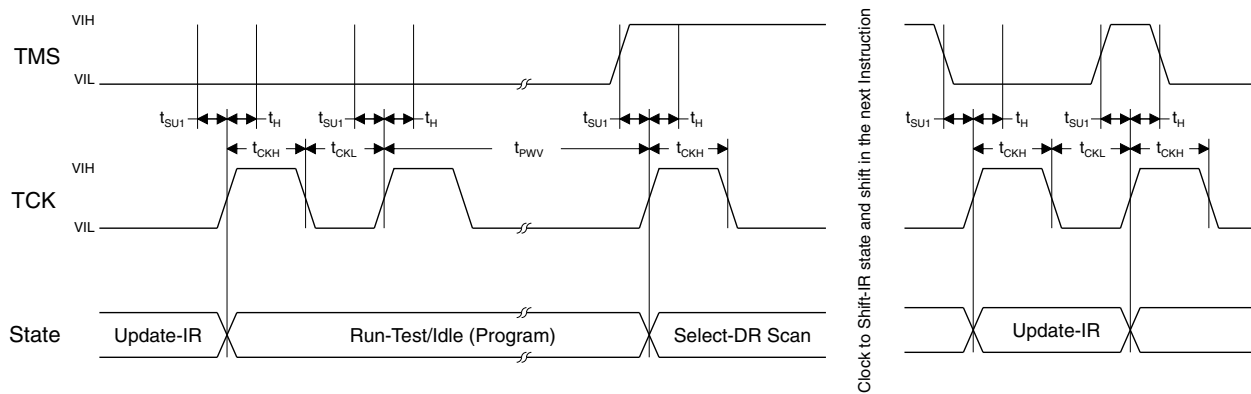
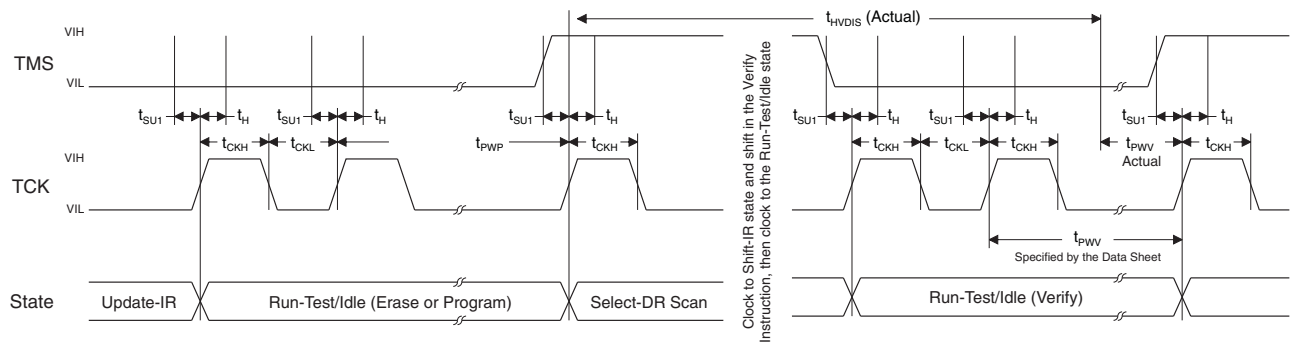

Figure 2-6. Discharge Timing Diagram



Theory of Operation

Analog Monitor Inputs

The ispPAC-POWR1014/A provides 10 independently programmable voltage monitor input circuits as shown in Figure 2-7. Two individually programmable trip-point comparators are connected to an analog monitoring input. Each comparator reference has 370 programmable trip points over the range of 0.672V to 5.867V. Additionally, a 75mV 'zero-detect' threshold is selectable which allows the voltage monitors to determine if a monitored signal has dropped to ground level. This feature is especially useful for determining if a power supply's output has decayed to a substantially inactive condition after it has been switched off.

Figure 2-7. ispPAC-POWR1014/A Voltage Monitors

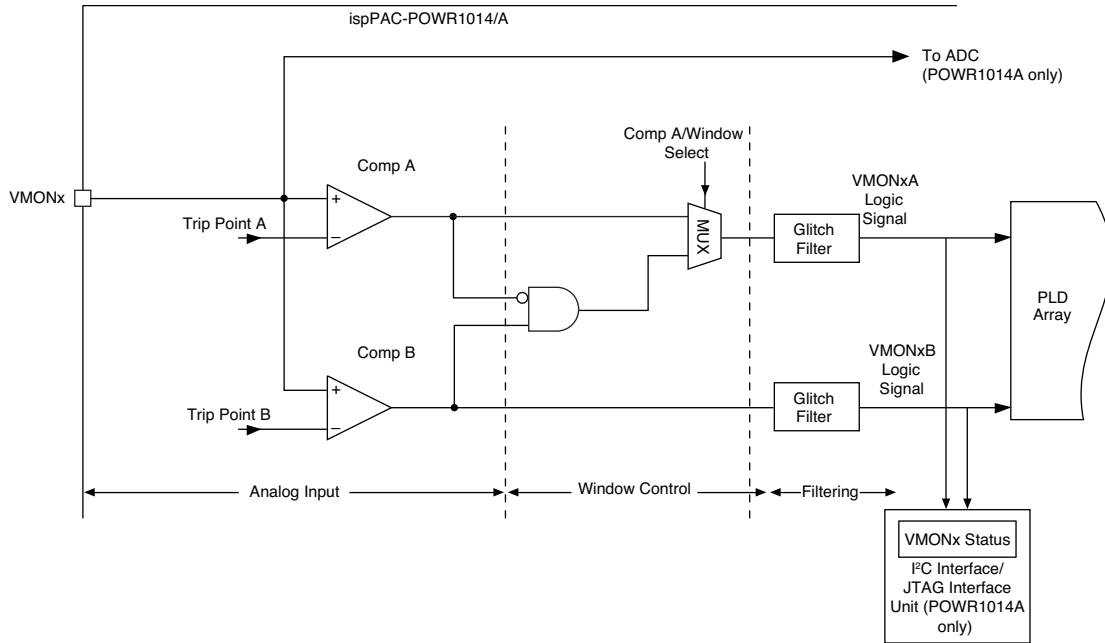

Figure 2-7 shows the functional block diagram of one of the 10 voltage monitor inputs - 'x' (where x = 1...10). Each voltage monitor can be divided into three sections: Analog Input, Window Control, and Filtering.

The voltage input is monitored by two individually programmable trip-point comparators, shown as CompA and CompB. Table 2-1 shows all trip points and the range to which any comparator's threshold can be set.

Each comparator outputs a HIGH signal to the PLD array if the voltage at its positive terminal is greater than its programmed trip point setting, otherwise it outputs a LOW signal.

A hysteresis of approximately 1% of the setpoint is provided by the comparators to reduce false triggering as a result of input noise. The hysteresis provided by the voltage monitor is a function of the input divider setting. Table 2-3 lists the typical hysteresis versus voltage monitor trip-point.

AGOOD Logic Signal

All the VMON comparators auto-calibrate immediately after a power-on reset event. During this time, the digital glitch filters are also initialized. This process completion is signalled by an internally generated logic signal: AGOOD. All logic using the VMON comparator logic signals must wait for the AGOOD signal to become active.

Programmable Over-Voltage and Under-Voltage Thresholds

Figure 2-8 (a) shows the power supply ramp-up and ramp-down voltage waveforms. Because of hysteresis, the comparator outputs change state at different thresholds depending on the direction of excursion of the monitored power supply.

Figure 2-8. (a) Power Supply Voltage Ramp-up and Ramp-down Waveform and the Resulting Comparator Output, (b) Corresponding to Upper and Lower Trip Points

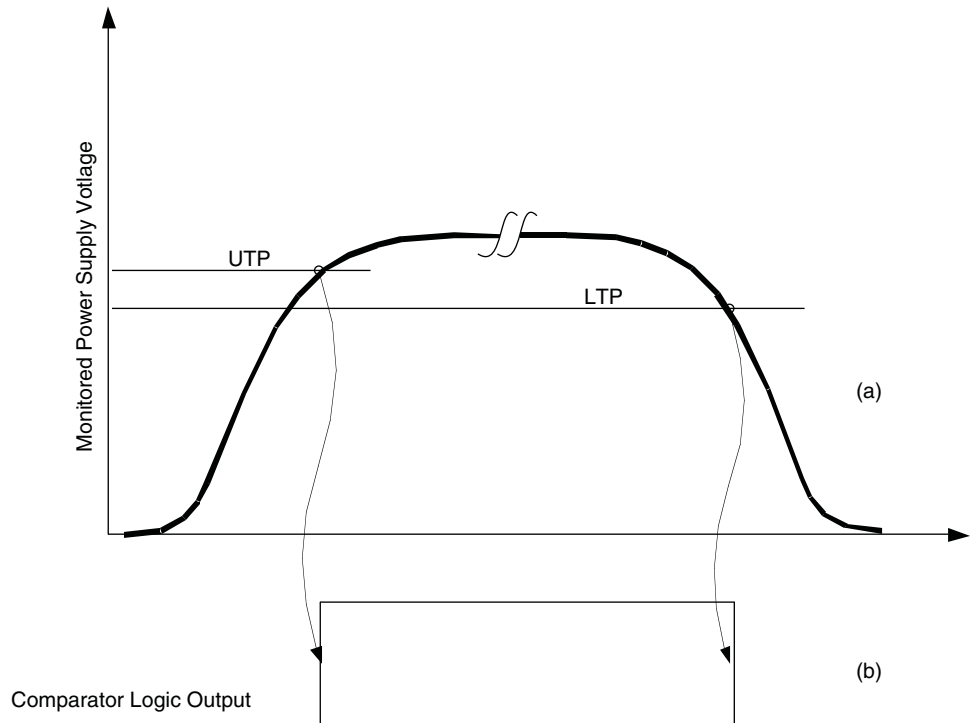

During power supply ramp-up the comparator output changes from logic 0 to 1 when the power supply voltage crosses the upper trip point (UTP). During ramp down the comparator output changes from logic state 1 to 0 when the power supply voltage crosses the lower trip point (LTP). To monitor for over-voltage fault conditions, the UTP should be used. To monitor under-voltage fault conditions, the LTP should be used.

Tables 2-1 and 2-2 show both the under-voltage and over-voltage trip points, which are automatically selected in software depending on whether the user is monitoring for an over-voltage condition or an under-voltage condition.

Table 2-1. Trip Point Table Used For Over-Voltage Detection

Coarse Range Setting												
Fine Range Setting	1	2	3	4	5	6	7	8	9	10	11	12
1	0.806	0.960	1.143	1.360	1.612	1.923	2.290	2.719	3.223	3.839	4.926	5.867
2	0.802	0.955	1.137	1.353	1.603	1.913	2.278	2.705	3.206	3.819	4.900	5.836
3	0.797	0.950	1.131	1.346	1.595	1.903	2.266	2.691	3.190	3.799	4.875	5.806
4	0.793	0.945	1.125	1.338	1.586	1.893	2.254	2.677	3.173	3.779	4.849	5.775
5	0.789	0.940	1.119	1.331	1.578	1.883	2.242	2.663	3.156	3.759	4.823	5.745
6	0.785	0.935	1.113	1.324	1.570	1.873	2.230	2.649	3.139	3.739	4.798	5.714
7	0.781	0.930	1.107	1.317	1.561	1.863	2.219	2.634	3.122	3.719	4.772	5.683
8	0.776	0.925	1.101	1.310	1.553	1.853	2.207	2.620	3.106	3.699	4.746	5.653
9	0.772	0.920	1.095	1.303	1.544	1.843	2.195	2.606	3.089	3.679	4.721	5.622
10	0.768	0.915	1.089	1.296	1.536	1.833	2.183	2.592	3.072	3.659	4.695	5.592
11	0.764	0.910	1.083	1.289	1.528	1.823	2.171	2.578	3.055	3.639	4.669	5.561
12	0.760	0.905	1.077	1.282	1.519	1.813	2.159	2.564	3.038	3.619	4.644	5.531
13	0.755	0.900	1.071	1.275	1.511	1.803	2.147	2.550	3.022	3.599	4.618	5.500
14	0.751	0.895	1.065	1.268	1.502	1.793	2.135	2.535	3.005	3.579	4.592	5.470
15	0.747	0.890	1.059	1.261	1.494	1.783	2.123	2.521	2.988	3.559	4.567	5.439
16	0.743	0.885	1.053	1.254	1.486	1.773	2.111	2.507	2.971	3.539	4.541	5.408
17	0.739	0.880	1.047	1.246	1.477	1.763	2.099	2.493	2.954	3.519	4.515	5.378
18	0.734	0.875	1.041	1.239	1.469	1.753	2.087	2.479	2.938	3.499	4.490	5.347
19	0.730	0.870	1.035	1.232	1.460	1.743	2.075	2.465	2.921	3.479	4.464	5.317
20	0.726	0.865	1.029	1.225	1.452	1.733	2.063	2.450	2.904	3.459	4.438	5.286
21	0.722	0.860	1.024	1.218	1.444	1.723	2.052	2.436	2.887	3.439	4.413	5.256
22	0.718	0.855	1.018	1.211	1.435	1.713	2.040	2.422	2.871	3.419	4.387	5.225
23	0.713	0.850	1.012	1.204	1.427	1.703	2.028	2.408	2.854	3.399	4.361	5.195
24	0.709	0.845	1.006	1.197	1.418	1.693	2.016	2.394	2.837	3.379	4.336	5.164
25	0.705	0.840	1.000	1.190	1.410	1.683	2.004	2.380	2.820	3.359	4.310	5.133
26	0.701	0.835	0.994	1.183	1.402	1.673	1.992	2.365	2.803	3.339	4.284	5.103
27	0.697	0.830	0.988	1.176	1.393	1.663	1.980	2.351	2.787	3.319	4.259	5.072
28	0.692	0.825	0.982	1.169	1.385	1.653	1.968	2.337	2.770	3.299	4.233	5.042
29	0.688	0.820	0.976	1.161	1.377	1.643	1.956	2.323	2.753	3.279	4.207	5.011
30	0.684	0.815	0.970	1.154	1.368	1.633	1.944	2.309	2.736	3.259	4.182	4.981
31	0.680	0.810	0.964	1.147	—	1.623	1.932	2.295	—	3.239	4.156	4.950
Low-V Sense	75mV											

Table 2-2. Trip Point Table Used For Under-Voltage Detection

Fine Range Setting	1	2	3	4	5	6	7	8	9	10	11	12
1	0.797	0.950	1.131	1.346	1.595	1.903	2.266	2.691	3.190	3.799	4.875	5.806
2	0.793	0.945	1.125	1.338	1.586	1.893	2.254	2.677	3.173	3.779	4.849	5.775
3	0.789	0.940	1.119	1.331	1.578	1.883	2.242	2.663	3.156	3.759	4.823	5.745
4	0.785	0.935	1.113	1.324	1.570	1.873	2.230	2.649	3.139	3.739	4.798	5.714
5	0.781	0.930	1.107	1.317	1.561	1.863	2.219	2.634	3.122	3.719	4.772	5.683
6	0.776	0.925	1.101	1.310	1.553	1.853	2.207	2.620	3.106	3.699	4.746	5.653
7	0.772	0.920	1.095	1.303	1.544	1.843	2.195	2.606	3.089	3.679	4.721	5.622
8	0.768	0.915	1.089	1.296	1.536	1.833	2.183	2.592	3.072	3.659	4.695	5.592
9	0.764	0.910	1.083	1.289	1.528	1.823	2.171	2.578	3.055	3.639	4.669	5.561
10	0.760	0.905	1.077	1.282	1.519	1.813	2.159	2.564	3.038	3.619	4.644	5.531
11	0.755	0.900	1.071	1.275	1.511	1.803	2.147	2.550	3.022	3.599	4.618	5.500
12	0.751	0.895	1.065	1.268	1.502	1.793	2.135	2.535	3.005	3.579	4.592	5.470
13	0.747	0.890	1.059	1.261	1.494	1.783	2.123	2.521	2.988	3.559	4.567	5.439
14	0.743	0.885	1.053	1.254	1.486	1.773	2.111	2.507	2.971	3.539	4.541	5.408
15	0.739	0.880	1.047	1.246	1.477	1.763	2.099	2.493	2.954	3.519	4.515	5.378
16	0.734	0.875	1.041	1.239	1.469	1.753	2.087	2.479	2.938	3.499	4.490	5.347
17	0.730	0.870	1.035	1.232	1.460	1.743	2.075	2.465	2.921	3.479	4.464	5.317
18	0.726	0.865	1.029	1.225	1.452	1.733	2.063	2.450	2.904	3.459	4.438	5.286
19	0.722	0.860	1.024	1.218	1.444	1.723	2.052	2.436	2.887	3.439	4.413	5.256
20	0.718	0.855	1.018	1.211	1.435	1.713	2.040	2.422	2.871	3.419	4.387	5.225
21	0.713	0.850	1.012	1.204	1.427	1.703	2.028	2.408	2.854	3.399	4.361	5.195
22	0.709	0.845	1.006	1.197	1.418	1.693	2.016	2.394	2.837	3.379	4.336	5.164
23	0.705	0.840	1.000	1.190	1.410	1.683	2.004	2.380	2.820	3.359	4.310	5.133
24	0.701	0.835	0.994	1.183	1.402	1.673	1.992	2.365	2.803	3.339	4.284	5.103
25	0.697	0.830	0.988	1.176	1.393	1.663	1.980	2.351	2.787	3.319	4.259	5.072
26	0.692	0.825	0.982	1.169	1.385	1.653	1.968	2.337	2.770	3.299	4.233	5.042
27	0.688	0.820	0.976	1.161	1.377	1.643	1.956	2.323	2.753	3.279	4.207	5.011
28	0.684	0.815	0.970	1.154	1.368	1.633	1.944	2.309	2.736	3.259	4.182	4.981
29	0.680	0.810	0.964	1.147	1.360	1.623	1.932	2.295	2.719	3.239	4.156	4.950
30	0.676	0.805	0.958	1.140	1.352	1.613	1.920	2.281	2.702	3.219	4.130	4.919
31	0.672	0.800	0.952	1.133	-	1.603	1.908	2.267	-	3.199	4.105	4.889
Low-V Sense	75mV											

Table 2-3. Comparator Hysteresis vs. Trip-Point

Trip-point Range (V)		Hysteresis (mV)
Low Limit	High Limit	
0.672	0.806	8
0.800	0.960	10
0.952	1.143	12
1.133	1.360	14
1.346	1.612	17
1.603	1.923	20
1.908	2.290	24
2.267	2.719	28
2.691	3.223	34
3.199	3.839	40
4.105	4.926	51
4.889	5.867	61
75 mV		0 (Disabled)

The window control section of the voltage monitor circuit is an AND gate (with inputs: an inverted COMPA “ANDed” with COMPB signal) and a multiplexer that supports the ability to develop a ‘window’ function without using any of the PLD’s resources. Through the use of the multiplexer, voltage monitor’s ‘A’ output may be set to report either the status of the ‘A’ comparator, or the window function of both comparator outputs. The voltage monitor’s ‘A’ output indicates whether the input signal is between or outside the two comparator thresholds. **Important:** This windowing function is only valid in cases where the threshold of the ‘A’ comparator is set to a value higher than that of the ‘B’ comparator. Table 2-4 shows the operation of window function logic.

Table 2-4. Voltage Monitor Windowing Logic

Input Voltage	Comp A	Comp B	Window (B and Not A)	Comment
$V_{IN} < \text{Trip-point B} < \text{Trip-point A}$	0	0	0	Outside window, low
$\text{Trip-point B} < V_{IN} < \text{Trip-point A}$	0	1	1	Inside window
$\text{Trip-point B} < \text{Trip-point A} < V_{IN}$	1	1	0	Outside window, high

Note that when the ‘A’ output of the voltage monitor circuit is set to windowing mode, the ‘B’ output continues to monitor the output of the ‘B’ comparator. This can be useful in that the ‘B’ output can be used to augment the windowing function by determining if the input is above or below the windowing range.

The third section in the ispPAC-POWR1014/A’s input voltage monitor is a digital filter. When enabled, the comparator output will be delayed by a filter time constant of 64 μs , and is especially useful for reducing the possibility of false triggering from noise that may be present on the voltages being monitored. When the filter is disabled, the comparator output will be delayed by 16 μs . In both cases, enabled or disabled, the filters also provide synchronization of the input signals to the PLD clock. This synchronous sampling feature effectively eliminates the possibility of race conditions from occurring in any subsequent logic that is implemented in the ispPAC-POWR1014/A’s internal PLD logic.

The comparator status can be read from the I²C interface or JTAG interface (ispPAC-POWR1014A only). For details on the I²C/JTAG interfaces, please refer to the I²C/SMBUS Interface, and Accessing I²C Registers Through JTAG sections of this data sheet.

VMON Voltage Measurement with the On-chip Analog to Digital Converter (ADC, ispPAC-POWR1014A Only)

The ispPAC-POWR1014A has an on-chip analog to digital converter that can be used for measuring the voltages at the VMON inputs.

Figure 2-9. ADC Monitoring VMON1 to VMON10

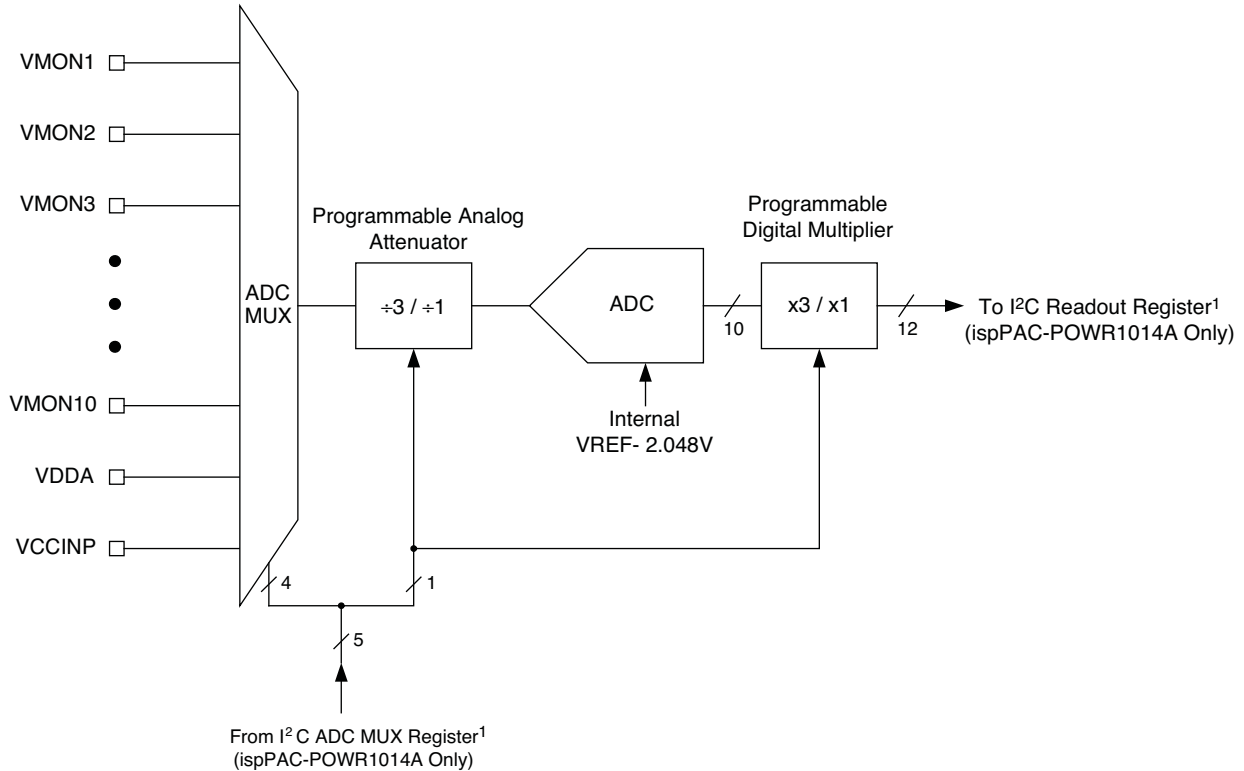

1. Can be accessed through JTAG port.

Figure 2-9 shows the ADC circuit arrangement within the ispPAC-POWR1014A device. The ADC can measure all analog input voltages through the multiplexer, ADC MUX. The programmable attenuator between the ADC mux and the ADC can be configured as divided-by-3 or divided-by-1 (no attenuation). The divided-by-3 setting is used to measure voltages from 0V to 6V range and divided-by-1 setting is used to measure the voltages from 0V to 2V range.

A microcontroller can place a request for any VMON voltage measurement at any time through the I²C/JTAGport (ispPAC-POWR1014A only). Upon the receipt of an ADCMUX selection command, the ADC will be connected to the selected VMON through the ADC MUX. The ADC output is then latched into the I²C readout registers. The contents of the ADC interface register can be read out from the I²C or JTAG port.

Calculation

The algorithm to convert the ADC code to the corresponding voltage takes into consideration the attenuation bit value. In other words, if the attenuation bit is set, then the 10-bit ADC result is automatically multiplied by 3 to calculate the actual voltage at that VMON input. Thus, the I²C readout register is 12 bits instead of 10 bits. The following formula can always be used to calculate the actual voltage from the ADC code.

Voltage at the VMONx Pins

$$VMON = I^2C \text{ Readout Register (12 bits}^2, \text{ converted to decimal)} * 2mV$$

²Note: ADC_VALUE_HIGH (8 bits), ADC_VALUE_LOW (4 bits) read from I²C/JTAG port (ispPAC-POWR1014A only).

PLD Block

Figure 2-10 shows the ispPAC-POWR1014/A PLD architecture, which is derived from the Lattice ispMACH® 4000 CPLD. The PLD architecture allows the flexibility in designing various state machines and control functions used for power supply management. The AND array has 53 inputs and generates 123 product terms. These 123 product terms are divided into three groups of 41 for each of the generic logic blocks, GLB1, GLB2, and GLB3. Each GLB is made up of eight macrocells. In total, there are 24 macrocells in the ispPAC-POWR1014/A device. The output signals of the ispPAC-POWR1014/A device are derived from GLBs as shown in Figure 2-10. GLB3 generates timer control.

Figure 2-10. ispPAC-POWR1014/A PLD Architecture

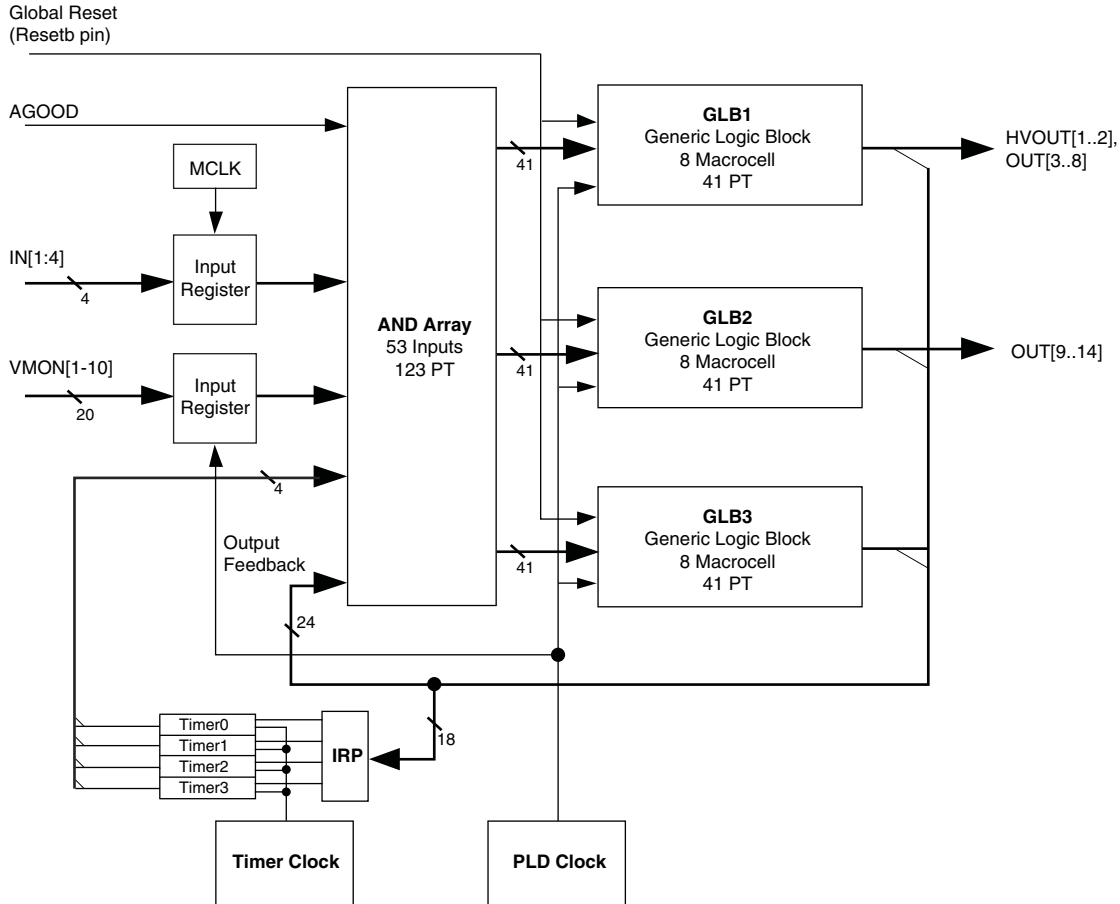

Macrocell Architecture

The macrocell shown in Figure 2-11 is the heart of the PLD. The basic macrocell has five product terms that feed the OR gate and the flip-flop. The flip-flop in each macrocell is independently configured. It can be programmed to function as a D-Type or T-Type flip-flop. Combinatorial functions are realized by bypassing the flip-flop. The polarity control and XOR gates provide additional flexibility for logic synthesis. The flip-flop's clock is driven from the common PLD clock that is generated by dividing the 8 MHz master clock by 32. The macrocell also supports asynchronous reset and preset functions, derived from either product terms, the global reset input, or the power-on reset signal. The resources within the macrocells share routing and contain a product term allocation array. The product term allocation array greatly expands the PLD's ability to implement complex logical functions by allowing logic to be shared between adjacent blocks and distributing the product terms to allow for wider decode functions. All the digital inputs are registered by MCLK and the VMON comparator outputs are registered by the PLD Clock to synchronize them to the PLD logic.

Figure 2-11. ispPAC-POWR1014/A Macrocell Block Diagram

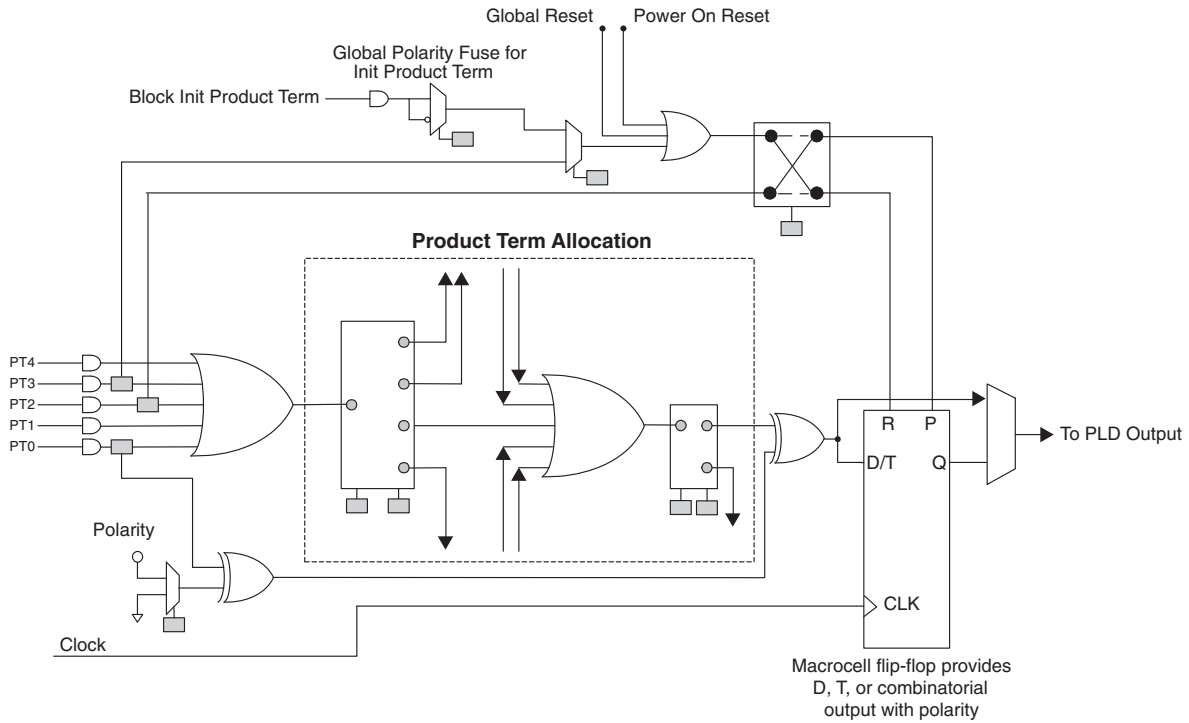

Clock and Timer Functions

Figure 2-12 shows a block diagram of the ispPAC-POWR1014/A’s internal clock and timer systems. The master clock operates at a fixed frequency of 8MHz, from which a fixed 250kHz PLD clock is derived.

Figure 2-12. Clock and Timer System

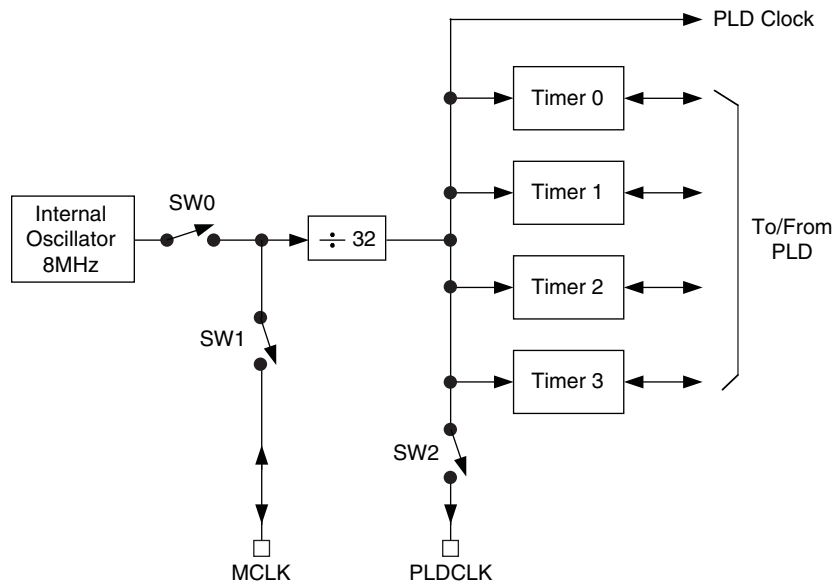

The internal oscillator runs at a fixed frequency of 8 MHz. This signal is used as a source for the PLD and timer clocks. It is also used for clocking the comparator outputs and clocking the digital filters in the voltage monitor cir-

cuits and ADC. The ispPAC-POWR1014/A can be programmed to operate in three modes: Master mode, Stand-alone mode and Slave mode. Table 2-5 summarizes the operating modes of ispPAC-POWR1014/A.

Table 2-5. ispPAC-POWR1014/A Operating Modes

Timer Operating Mode	SW0	SW1	Condition	Comments
Standalone	Closed	Open	When only one ispPAC-POWR1014/A is used.	MCLK pin tristated
Master	Closed	Closed	When more than one ispPAC-POWR1014/A is used on a board, one of them should be configured to operate in this mode.	MCLK pin outputs 8MHz clock
Slave	Open	Closed	When more than one ispPAC-POWR1014/As is used on a board. Other than the master, the rest of the ispPAC-POWR1014/As should be programmed as slaves.	MCLK pin is input

A divide-by-32 prescaler divides the internal 8MHz oscillator (or external clock, if selected) down to 250kHz for the PLD clock and for the programmable timers. This PLD clock may be made available on the PLDCLK pin by closing SW2. Each of the four timers provides independent timeout intervals ranging from 32µs to 1.96 seconds in 128 steps.

Digital Outputs

The ispPAC-POWR1014/A provides 14 digital outputs, HVOUT[1:2] and OUT[3:14]. Outputs OUT[3:14] are permanently configured as open drain to provide a high degree of flexibility when interfacing to logic signals, LEDs, opto-couplers, and power supply control inputs. The HVOUT[1:2] pins can be configured as either high voltage FET drivers or open drain outputs. Each of these outputs may be controlled either from the PLD or from the I²C register (ispPAC-POWR1014A only). The determination whether a given output is under PLD or I²C control may be made on a pin-by-pin basis (see Figure 2-13). For further details on controlling the outputs through I²C, please see the I²C/SMBUS Interface and Accessing I²C Registers Through JTAG sections of this data sheet.

Figure 2-13. Digital Output Pin Configuration

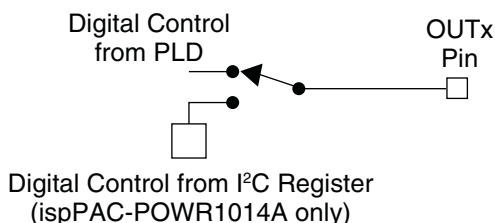

High-Voltage Outputs

In addition to being usable as digital open-drain outputs, the ispPAC-POWR1014/A's HVOUT1-HVOUT2 output pins can be programmed to operate as high-voltage FET drivers. Figure 2-14 shows the details of the HVOUT gate drivers. Each of these outputs may be controlled from the PLD, or with the ispPAC-POWR1014A, from the I²C registers (see Figure 2-14). For further details on controlling the outputs through I²C, please see the I²C/SMBUS Interface, and Accessing I²C Registers Through JTAG sections of this data sheet.

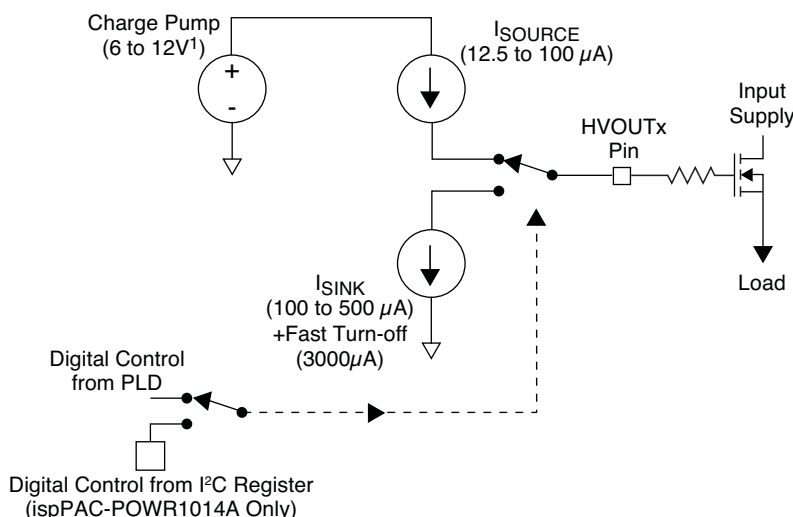
Figure 2-14. Basic Function Diagram for an Output in High Voltage MOSFET Gate Driver Mode

1. -01 performance grade devices provide three selectable output voltage settings from 6V to 10V in 2V steps. The -02 performance grade devices also support the 12V output voltage setting.

Figure 2-14 shows the HVOUT circuitry when programmed as a FET driver. In this mode the output either sources current from a charge pump or sinks current. The maximum voltage that the output level at the pin will rise to is also programmable between 6V and 12V¹. The maximum voltage levels that are required depend on the gate-to-source threshold of the FET being driven and the power supply voltage being switched. The maximum voltage level needs to be sufficient to bias the gate-to-source threshold on and also accommodate the load voltage at the FET's source, since the source pin of the FET to provide a wide range of ramp rates is tied to the supply of the target board. When the HVOUT pin is sourcing current, charging a FET gate, the source current is programmable between 12.5µA and 100µA. When the driver is turned to the off state, the driver will sink current to ground, and this sink current is also programmable between 3000µA and 100µA to control the turn-off rate.

Programmable Output Voltage Levels for HVOUT1- HVOUT2

There are four¹ selectable steps for the output voltage of the FET drivers when in FET driver mode. The voltage that the pin is capable of driving to can be programmed from 6V to 12V¹ in 2V steps.

1. -01 performance grade devices provide three selectable output voltage settings from 6V to 10V in 2V steps. The -02 performance grade devices also support the 12V output voltage setting.

RESETb Signal, RESET Command via JTAG or I²C

Activating the RESETb signal (Logic 0 applied to the RESETb pin) or issuing a reset instruction via JTAG, or with the ispPAC-POWR1014A, I²C will force the outputs to the following states independent of how these outputs have been configured in the PINS window:

- OUT3-14 will go high-impedance.
- HVOUT pins programmed for open drain operation will go high-impedance.
- HVOUT pins programmed for FET driver mode operation will pull down.

At the conclusion of the RESET event, these outputs will go to the states defined by the PINS window, and if a sequence has been programmed into the device, it will be re-started at the first step. The analog calibration will be re-done and consequently, the VMONs, and ADCs will not be operational until 500 microseconds (max.) after the conclusion of the RESET event.

CAUTION: Activating the RESETb signal or issuing a RESET command through I2C or JTAG during the ispPAC-POWR1014/A device operation, results in the device aborting all operations and returning to the power-on reset state. The status of the power supplies which are being enabled by the ispPAC-POWR1014/A will be determined by the state of the outputs shown above.

I²C/SMBUS Interface (ispPAC-POWR1014A Only)

I²C and SMBus are low-speed serial interface protocols designed to enable communications among a number of devices on a circuit board. The ispPAC-POWR1014A supports a 7-bit addressing of the I²C communications protocol, as well as SMBTimeout and SMBAlert features of the SMBus, enabling it to easily integrated into many types of modern power management systems. Figure 2-15 shows a typical I²C configuration, in which one or more ispPAC-POWR1014As are slaved to a supervisory microcontroller. SDA is used to carry data signals, while SCL provides a synchronous clock signal. The SMBAlert line is only present in SMBus systems. The 7-bit I²C address of the POWR1014A is fully programmable through the JTAG port.

Figure 2-15. ispPAC-POWR1014A in I²C/SMBUS System

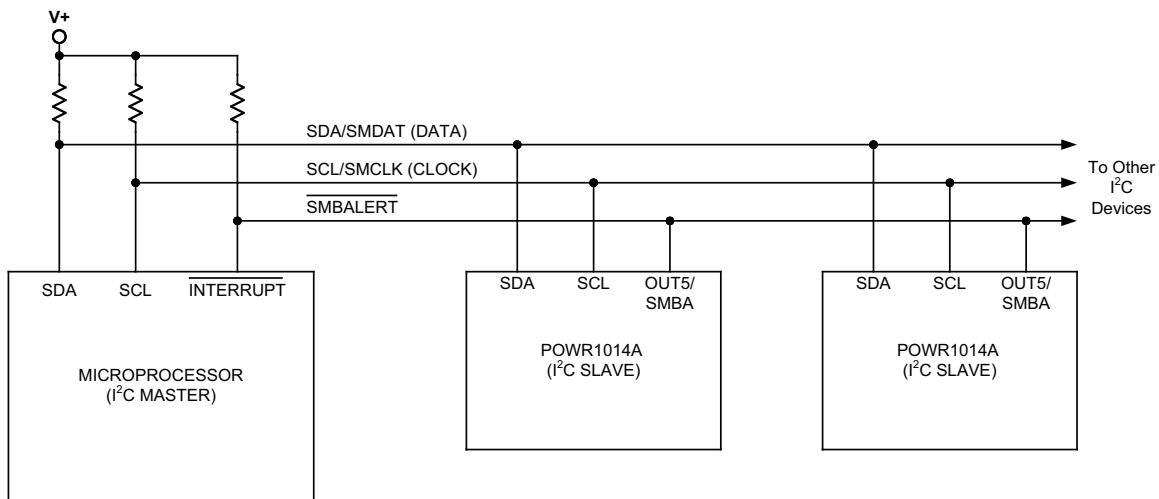

In both the I²C and SMBus protocols, the bus is controlled by a single MASTER device at any given time. This master device generates the SCL clock signal and coordinates all data transfers to and from a number of slave devices. The ispPAC-POWR1014A is configured as a slave device, and cannot independently coordinate data transfers. Each slave device on a given I²C bus is assigned a unique address. The ispPAC-POWR1014A implements the 7-bit addressing portion of the standard. Any 7-bit address can be assigned to the ispPAC-POWR1014A device by programming through JTAG. When selecting a device address, one should note that several addresses are reserved by the I²C and/or SMBus standards, and should not be assigned to ispPAC-POWR1014A devices to assure bus compatibility. Table 2-6 lists these reserved addresses.

Table 2-6. I²C/SMBus Reserved Slave Device Addresses

Address	R/W bit	I ² C function Description	SMBus Function
0000 000	0	General Call Address	General Call Address
0000 000	1	Start Byte	Start Byte
0000 001	x	CBUS Address	CBUS Address
0000 010	x	Reserved	Reserved
0000 011	x	Reserved	Reserved
0000 1xx	x	HS-mode master code	HS-mode master code
0001 000	x	NA	SMBus Host
0001 100	x	NA	SMBus Alert Response Address
0101 000	x	NA	Reserved for ACCESS.bus
0110 111	x	NA	Reserved for ACCESS.bus
1100 001	x	NA	SMBus Device Default Address
1111 0xx	x	10-bit addressing	10-bit addressing
1111 1xx	x	Reserved	Reserved

The ispPAC-POWR1014A’s I²C/SMBus interface allows data to be both written to and read from the device. A data write transaction (Figure 2-16) consists of the following operations:

1. Start the bus transaction
2. Transmit the device address (7 bits) along with a low write bit
3. Transmit the address of the register to be written to (8 bits)
4. Transmit the data to be written (8 bits)
5. Stop the bus transaction

To start the transaction, the master device holds the SCL line high while pulling SDA low. Address and data bits are then transferred on each successive SCL pulse, in three consecutive byte frames of 9 SCL pulses. Address and data are transferred on the first 8 SCL clocks in each frame, while an acknowledge signal is asserted by the slave device on the 9th clock in each frame. Both data and addresses are transferred in a most-significant-bit-first format. The first frame contains the 7-bit device address, with bit 8 held low to indicate a write operation. The second frame contains the register address to which data will be written, and the final frame contains the actual data to be written. Note that the SDA signal is only allowed to change when the SCL is low, as raising SDA when SCL is high signals the end of the transaction.

Figure 2-16. I²C Write Operation

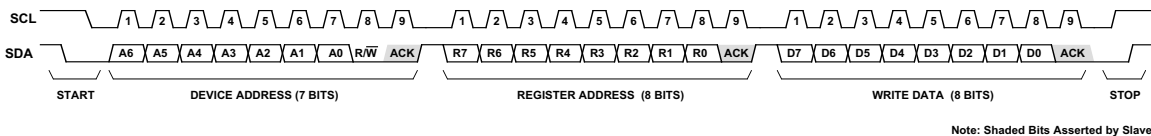

Reading a data byte from the ispPAC-POWR1014A requires two separate bus transactions (Figure 2-17). The first transaction writes the register address from which a data byte is to be read. Note that since no data is being written to the device, the transaction is concluded after the second byte frame. The second transaction performs the actual read. The first frame contains the 7-bit device address with the R/W bit held High. In the second frame the ispPAC-POWR1014A asserts data out on the bus in response to the SCL signal. Note that the acknowledge signal in the second frame is asserted by the master device and not the ispPAC-POWR1014A.

Figure 2-17. I²C Read Operation

STEP 1: WRITE REGISTER ADDRESS FOR READ OPERATION

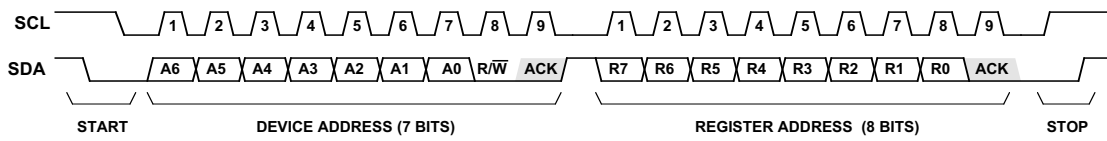

STEP 2: READ DATA FROM THAT REGISTER

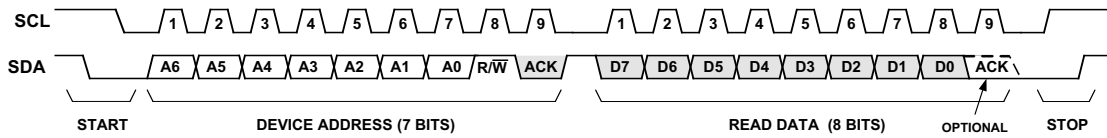

Note: Shaded Bits Asserted by Slave

The ispPAC-POWR1014A provides 17 registers that can be accessed through its I²C interface. These registers provide the user with the ability to monitor and control the device's inputs and outputs, and transfer data to and from the device. Table 2-7 provides a summary of these registers.

Table 2-7. I²C Control Registers¹

Register Address	Register Name	Read/Write	Description	Value After POR ^{2,3}
0x00	vmon_status0	R	VMON input status Vmon[4:1]	---- ----
0x01	vmon_status1	R	VMON input status Vmon[8:5]	---- ----
0x02	vmon_status2	R	VMON input status Vmon[10:9]	X X X X ----
0x03	output_status0	R	Output status OUT[8:3], HVOUT[2:1]	---- ----
0x04	output_status1	R	Output status OUT[14:9]	X X -- ----
0x06	input_status	R	Input status IN[4:1]	X X X X ----
0x07	adc_value_low	R	ADC D[3:0] and status	---- X X X 1
0x08	adc_value_high	R	ADC D[9:4]	X X -- ----
0x09	adc_mux	R/W	ADC Attenuator and MUX[3:0]	X X X 1 1 1 1 1
0x0A	UES_byte0	R	UES[7:0]	---- ----
0x0B	UES_byte1	R	UES[15:8]	---- ----
0x0C	UES_byte2	R	UES[23:16]	---- ----
0x0D	UES_byte3	R	UES[31:24]	---- ----
0x0E	gp_output1	R/W	GPOUT[8:1]	0 0 0 0 0 1 0 0
0x0F	gp_output2	R/W	GPOUT[14:9]	X X 0 0 0 0 0 0
0x11	input_value	R/W	PLD Input Register [4:2]	X X X X 0 0 0 X
0x12	reset	W	Resets device on write	N/A

1. These registers can also be accessed through the JTAG interface.
2. "X" = Non-functional bit (bits read out as 1's).
3. "-" = State depends on device configuration or input status.

Several registers are provided for monitoring the status of the analog inputs. The three registers VMON_STATUS[0:2] provide the ability to read the status of the VMON output comparators. The ability to read both the 'a' and 'b' comparators from each VMON input is provided through the VMON input registers. Note that if a VMON input is configured to window comparison mode, then the corresponding VMONxA register bit will reflect the status of the window comparison.

Figure 2-18. VMON Status Registers

0x00 - VMON_STATUS0 (Read Only)

VMON4B	VMON4A	VMON3B	VMON3A	VMON2B	VMON2A	VMON1B	VMON1A
b7	b6	b5	b4	b3	b2	b1	b0

0x01 - VMON_STATUS1 (Read Only)

VMON8B	VMON8A	VMON7B	VMON7A	VMON6B	VMON6A	VMON5B	VMON5A
b7	b6	b5	b4	b3	b2	b1	b0

0x02 - VMON_STATUS2 (Read Only)

1	1	1	1	VMON10B	VMON10A	VMON9B	VMON9A
b7	b6	b5	b4	b3	b2	b1	b0

It is also possible to directly read the value of the voltage present on any of the VMON inputs by using the ispPAC-POWR1014A's ADC. Three registers provide the I²C interface to the ADC (Figure 2-19).

Figure 2-19. ADC Interface Registers

0x07 - ADC_VALUE_LOW (Read Only)

D3	D2	D1	D0	1	1	1	DONE
b7	b6	b5	b4	b3	b2	b1	b0

0x08 - ADC_VALUE_HIGH (Read Only)

D11	D10	D9	D8	D7	D6	D5	D4
b7	b6	b5	b4	b3	b2	b1	b0

0x09 - ADC_MUX (Read/Write)

X	X	X	ATTEN	SEL3	SEL2	SEL1	SEL0
b7	b6	b5	b4	b3	b2	b1	b0

To perform an A/D conversion, one must set the input attenuator and channel selector. Two input ranges may be set using the attenuator, 0 - 2.048V and 0 - 6.144V. Table 2-8 shows the input attenuator settings.

Table 2-8. ADC Input Attenuator Control

ATTEN (ADC_MUX.4)	Resolution	Full-Scale Range
0	2mV	2.048 V
1	6mV	6.144 V

The input selector may be set to monitor any one of the ten VMON inputs, the VCCA input, or the VCCINP input. Table 2-9 shows the codes associated with each input selection.

Table 2-9. V_{MON} Address Selection Table

Select Word				Input Channel
SEL3 (ADC_MUX.3)	SEL2 (ADC_MUX.2)	SEL1 (ADC_MUX.1)	SEL0 (ADC_MUX.0)	
0	0	0	0	VMON1
0	0	0	1	VMON2
0	0	1	0	VMON3
0	0	1	1	VMON4
0	1	0	0	VMON5
0	1	0	1	VMON6
0	1	1	0	VMON7
0	1	1	1	VMON8
1	0	0	0	VMON9
1	0	0	1	VMON10
1	1	0	0	VCCA
1	1	0	1	VCCINP

Writing a value to the ADC_MUX register to set the input attenuator and selector will automatically initiate a conversion. When the conversion is in process, the DONE bit (ADC_VALUE_LOW.0) will be reset to 0. When the conversion is complete, this bit will be set to 1. When the conversion is complete, the result may be read out of the ADC by performing two I²C read operations; one for ADC_VALUE_LOW, and one for ADC_VALUE_HIGH. It is recommended that the I²C master load a second conversion command only after the completion of the current conversion

command (Waiting for the DONE bit to be set to 1). An alternative would be to wait for a minimum specified time (see $T_{CONVERT}$ value in the specifications) and disregard checking the DONE bit.

Note that if the I²C clock rate falls below 50kHz (see F_{I2C} note in specifications), the only way to insure a valid ADC conversion is to wait the minimum specified time ($T_{CONVERT}$), as the operation of the DONE bit at clock rates lower than that cannot be guaranteed. In other words, if the I²C clock rate is less than 50kHz, the DONE bit may or may not assert even though a valid conversion result is available.

To insure every ADC conversion result is valid, preferred operation is to clock I²C at more than 50kHz and verify DONE bit status or wait for the full $T_{CONVERT}$ time period between subsequent ADC convert commands. If an I²C request is placed before the current conversion is complete, the DONE bit will be set to 1 only after the second request is complete.

The status of the digital input lines may also be monitored and controlled through I²C commands. Figure 2-20 shows the I²C interface to the IN[1:4] digital input lines. The input status may be monitored by reading the INPUT_STATUS register, while input values to the PLD array may be set by writing to the INPUT_VALUE register. To be able to set an input value for the PLD array, the input multiplexer associated with that bit needs to be set to the I²C register setting in E²CMOS memory otherwise the PLD will receive its input from the INx pin.

Figure 2-20. I²C Digital Input Interface

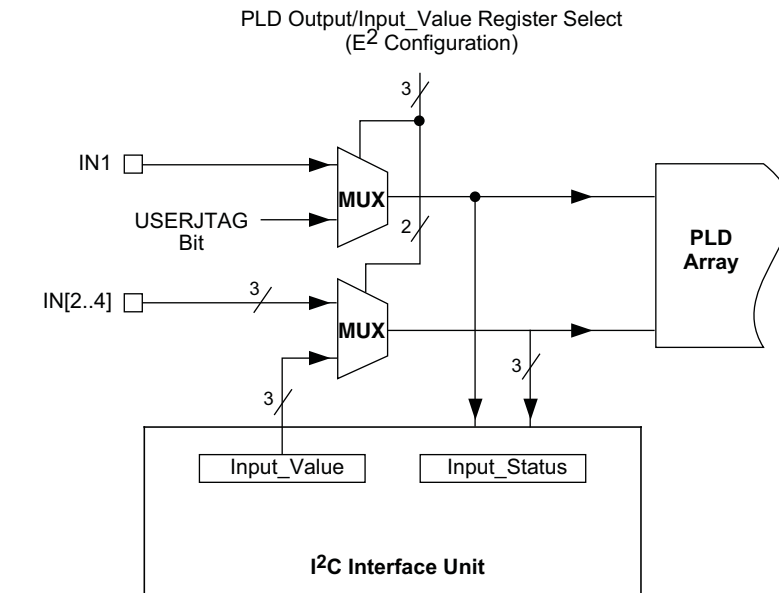

0x06 - INPUT_STATUS (Read Only)

1	1	1	1	IN4	IN3	IN2	IN1
b7	b6	b5	b4	b3	b2	b1	b0

0x11 - INPUT_VALUE (Read/Write)

X	X	X	X	I4	I3	I2	X
b7	b6	b5	b4	b3	b2	b1	b0

The digital outputs may also be monitored and controlled through the I²C interface, as shown in Figure 2-21. The status of any given digital output may be read by reading the contents of the associated OUTPUT_STATUS[1:0] register. Note that in the case of the outputs, the status reflected by these registers reflects the logic signal used to drive the pin, and does not sample the actual level present on the output pin. For example, if an output is set high

but is not pulled up, the output status bit corresponding with that pin will read '1', but a high output signal will not appear on the pin.

Digital outputs may also be optionally controlled directly by the I²C bus instead of by the PLD array. The outputs may be driven either from the PLD output or from the contents of the GP_OUTPUT[1:0] registers with the choice user-settable in E²CMOS memory. Each output may be independently set to output from the PLD or from the GP_OUTPUT registers.

Figure 2-21. I²C Output Monitor and Control Logic

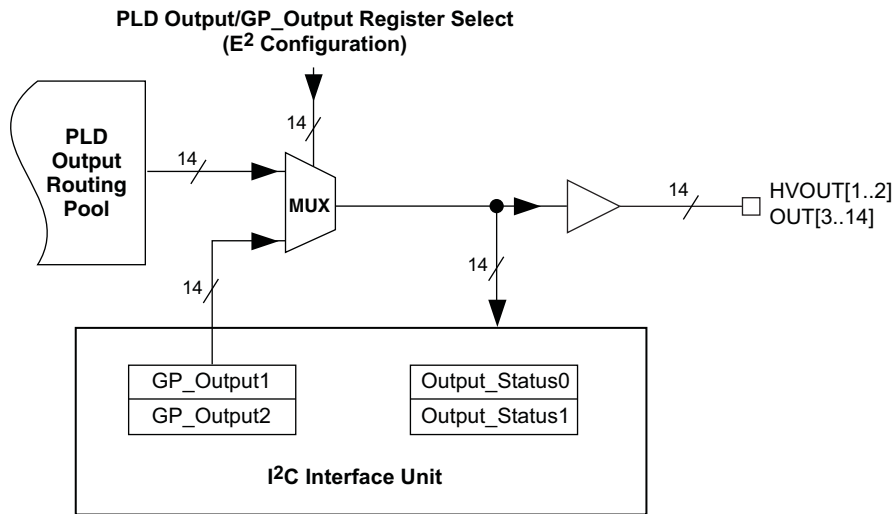

0x03 - OUTPUT_STATUS0 (Read Only)

OUT8	OUT7	OUT6	OUT5	OUT4	OUT3	HVOUT2	HVOUT1
b7	b6	b5	b4	b3	b2	b1	b0

0x04 - OUTPUT_STATUS1 (Read Only)

1	1	OUT14	OUT13	OUT12	OUT11	OUT10	OUT9
b7	b6	b5	b4	b3	b2	b1	b0

0x0E - GP_OUTPUT1 (Read/Write)

GP8	GP7	GP6	GP5	GP4	GP3_ENb	GP2	GP1
b7	b6	b5	b4	b3	b2	b1	b0

0x0F - GP_OUTPUT2 (Read/Write)

X	X	GP14	GP13	GP12	GP11	GP10	GP9
b7	b6	b5	b4	b3	b2	b1	b0

The UES word may also be read through the I²C interface, with the register mapping shown in Figure 2-22.

Figure 2-22. I²C Register Mapping for UES Bits

0x0A - UES_BYTE0 (Read Only)

UES7	UES6	UES5	UES4	UES3	UES2	UES1	UES0
b7	b6	b5	b4	b3	b2	b1	b0

0x0B - UES_BYTE1 (Read Only)

UES15	UES14	UES13	UES12	UES11	UES10	UES9	UES8
b7	b6	b5	b4	b3	b2	b1	b0

0x0C - UES_BYTE2 (Read Only)

UES23	UES22	UES21	UES20	UES19	UES18	UES17	UES16
b7	b6	b5	b4	b3	b2	b1	b0

0x0D - UES_BYTE3 (Read Only)

UES31	UES30	UES29	UES28	UES27	UES26	UES25	UES24
b7	b6	b5	b4	b3	b2	b1	b0

The I²C interface also provides the ability to initiate reset operations. The ispPAC-POWR1014A may be reset by issuing a write of any value to the I²C RESET register (Figure 2-23). Note: The execution of the I²C reset command is equivalent to toggling the Resetb pin of the chip. Refer to the Resetb Signal, RESET Command via JTAG or I²C section of this data sheet for further information.

Figure 2-23. I²C Reset Register

0x12 - RESET (Write Only)

X	X	X	X	X	X	X	X
b7	b6	b5	b4	b3	b2	b1	b0

SMBus SMBAlert Function

The ispPAC-POWR1014A provides an SMBus SMBAlert function so that it can request service from the bus master when it is used as part of an SMBus system. This feature is supported as an alternate function of OUT3. When the SMBAlert feature is enabled, OUT3 is controlled by a combination of the PLD output and the GP3_ENb bit (Figure 2-24). Note: To enable the SMBAlert feature, the SMB_Mode (EECMOS bit) should be set in software.

Figure 2-24. ispPAC-POWR1014/A SMBAlert Logic

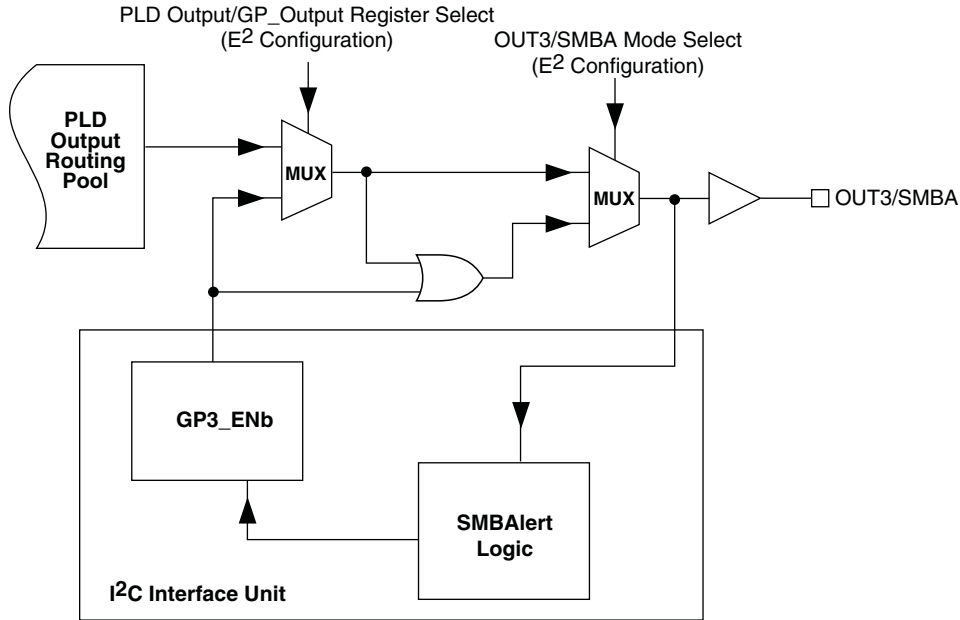

The typical flow for an SMBAlert transaction is as follows (Figure 2-24):

1. GP3_ENb bit is forced (Via I²C write) to Low
2. ispPAC-POWR1014A PLD Logic pulls OUT3/SMBA Low
3. Master responds to interrupt from SMBA line
4. Master broadcasts a read operation using the SMBus Alert Response Address (ARA)
5. ispPAC-POWR1014A responds to read request by transmitting its device address
6. If transmitted device address matches ispPAC-POWR1014A address, it sets GP3_ENb bit high. This releases OUT3/SMBA.

Figure 2-25. SMBAlert Bus Transaction

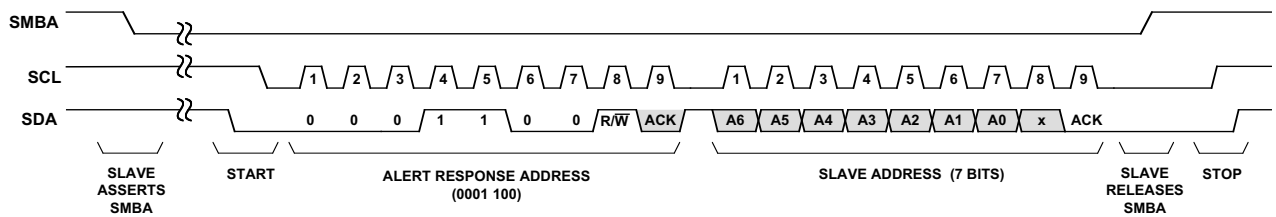

Note: Shaded Bits Asserted by Slave

After OUT3/SMBA has been released, the bus master (typically a microcontroller) may opt to perform some service functions in which it may send data to or read data from the ispPAC-POWR1014A. As part of the service functions, the bus master will typically need to clear whatever condition initiated the SMBAlert request, and will also need to reset GP3_ENb to re-enable the SMBAlert function. For further information on the SMBus, the user should consult the SMBus Standard.

Software-Based Design Environment

Designers can configure the ispPAC-POWR1014/A using PAC-Designer, an easy to use, Microsoft Windows compatible program. Circuit designs are entered graphically and then verified, all within the PAC-Designer environment. Full device programming is supported using PC parallel port I/O operations and a download cable connected to the serial programming interface pins of the ispPAC-POWR1014/A. A library of configurations is included with basic solutions and examples of advanced circuit techniques are available on the Lattice web site for downloading. In addition, comprehensive on-line and printed documentation is provided that covers all aspects of PAC-Designer operation. The PAC-Designer schematic window, shown in Figure 2-26, provides access to all configurable ispPAC-POWR1014/A elements via its graphical user interface. All analog input and output pins are represented. Static or non-configurable pins such as power, ground, and the serial digital interface are omitted for clarity. Any element in the schematic window can be accessed via mouse operations as well as menu commands. When completed, configurations can be saved, simulated, and downloaded to devices.

Figure 2-26. PAC-Designer ispPAC-POWR1014/A Design Entry Screen

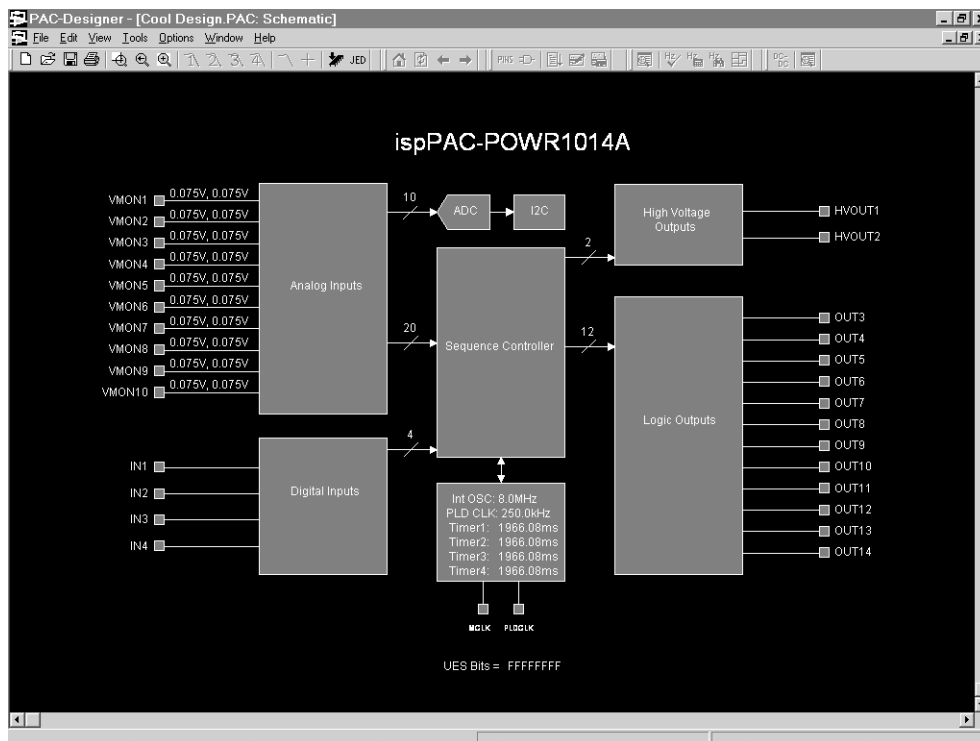

In-System Programming

The ispPAC-POWR1014/A is an in-system programmable device. This is accomplished by integrating all E² configuration memory and control logic on-chip. Programming is performed through a 4-wire, IEEE 1149.1 compliant serial JTAG interface at normal logic levels. Once a device is programmed, all configuration information is stored on-chip, in non-volatile E²CMOS memory cells. The specifics of the IEEE 1149.1 serial interface and all ispPAC-POWR1014/A instructions are described in the JTAG interface section of this data sheet.

Programming ispPAC-POWR1014/A: Alternate Method

Some applications require that the ispPAC-POWR1014/A be programmed before turning the power on to the entire circuit board. To meet such application needs, the ispPAC-POWR1014/A provides an alternate programming method which enables the programming of the ispPAC-POWR1014/A device through the JTAG chain with a separate power supply applied just to the programming section of the ispPAC-POWR1014/A device with the main power supply of the board turned off.

Three special purpose pins, VCCPROG, ATDI and TDISEL, enable programming of the un-programmed ispPAC-POWR1014/A under such circumstances. The VCCPROG pin provides power to the programming circuitry of the ispPAC-POWR1014/A device (when VCCD and VCCA are unpowered). The VCCJ pin must be powered to enable the JTAG port. The ATDI pin provides an alternate connection to the JTAG header while bypassing all the un-powered devices in the JTAG chain. TDISEL pin enables switching between the ATDI and the standard JTAG signal TDI. When the internally pulled-up TDISEL = 1, standard TDI pin is enabled and when the TDISEL = 0, ATDI is enabled.

In order to use this feature the JTAG signals of the ispPAC-POWR1014/A are connected to the header as shown in Figure 2-27. Note: The ispPAC-POWR1014/A should be the last device in the JTAG chain.

After programming, the VCCPROG pin MUST be left floating before applying power to the VCCD and VCCA pins.

Figure 2-27. ispPAC-POWR1014/A Alternate TDI Configuration Diagram

Alternate TDI Selection Via JTAG Command

When the TDISEL pin held high and four consecutive IDCODE instructions are issued, ispPAC-POWR1014/A responds by making its active JTAG data input the ATDI pin. When ATDI is selected, data on its TDI pin is ignored until the JTAG state machine returns to the Test-Logic-Reset state.

This method of selecting ATDI takes advantage of the fact that a JTAG device with an IDCODE register will automatically load its unique IDCODE instruction into the Instruction Register after a Test-Logic-Reset. This JTAG capability permits blind interrogation of devices so that their location in a serial chain can be identified without having to know anything about them in advance. A blind interrogation can be made using only the TMS and TCLK control pins, which means TDI and TDO are not required for performing the operation. Figure 2-28 illustrates the logic for selecting whether the TDI or ATDI pin is the active data input to ispPAC-POWR1014/A.

Figure 2-28. ispPAC-POWR1014/A TDI/ATDI Pin Selection Diagram

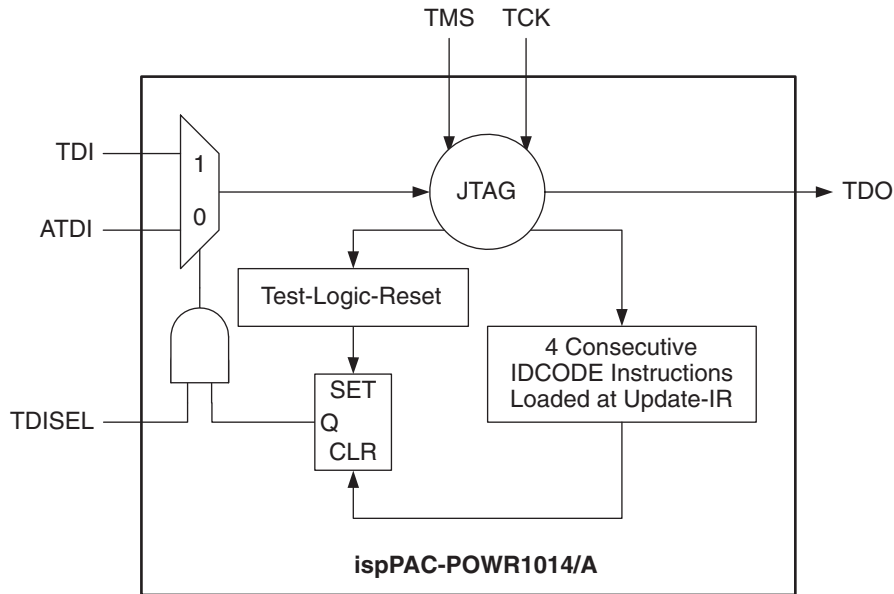

Table 2-10 shows in truth table form the same conditions required to select either TDI or ATDI as in the logic diagram found in Figure 2-28.

Table 2-10. ispPAC-POWR1014/A ATDI/TDI Selection Table

TDISEL Pin	JTAG State Machine Test-Logic-Reset	4 Consecutive IDCODE Commands Loaded at Update-IR	Active JTAG Data Input Pin
H	No	Yes	ATDI (TDI Disabled)
H	Yes	No	TDI (ATDI Disabled)
L	X	X	ATDI (TDI Disabled)

Please refer to AN6068, [Programming the ispPAC-POWR1220AT8 in a JTAG Chain Using ATDI](#). This application note includes specific SVF code examples and information on the use of Lattice design tools to verify device operation in alternate TDI mode.

VCCPROG Power Supply Pin

Because the VCCPROG pin directly powers the on-chip programming circuitry, the ispPAC-POWR1014/A device can be programmed by applying power to the VCCPROG pin (without powering the entire chip though the VCCD and VCCA pins). In addition, to enable the on-chip JTAG interface circuitry, power should be applied to the VCCJ pin.

When the ispPAC-POWR1014/A is powered by the VCCPROG pin, no power should be applied to the VCCD and VCCA pins. Additionally, other than JTAG I/O pins, all digital output pins are in Hi-Z state, HVOUT pins configured as MOSFET driver are driven low, and all other inputs are ignored.

To switch the power supply back to VCCD and VCCA pins, one should turn the VCCPROG supply and VCCJ off before turning the regular supplies on. When VCCD and VCCA are turned back on for normal operation, VCCPROG MUST be left floating.

The VCCPROG pin should not be connected to the VCCD and VCCA pins.

User Electronic Signature

A user electronic signature (UES) feature is included in the E²CMOS memory of the ispPAC-POWR1014/A. This consists of 32 bits that can be configured by the user to store unique data such as ID codes, revision numbers or inventory control data. The specifics of this feature are discussed in the IEEE 1149.1 serial interface section of this data sheet.

Electronic Security

An electronic security “fuse” (ESF) bit is provided in every ispPAC-POWR1014/A device to prevent unauthorized readout of the E²CMOS configuration bit patterns. Once programmed, this cell prevents further access to the functional user bits in the device. This cell can only be erased by reprogramming the device, so the original configuration cannot be examined once programmed. Usage of this feature is optional. The specifics of this feature are discussed in the IEEE 1149.1 serial interface section of this data sheet.

Production Programming Support

Once a final configuration is determined, an ASCII format JEDEC file can be created using the PAC-Designer software. Devices can then be ordered through the usual supply channels with the user’s specific configuration already preloaded into the devices. By virtue of its standard interface, compatibility is maintained with existing production programming equipment, giving customers a wide degree of freedom and flexibility in production planning.

Evaluation Fixture

Because the features of an ispPAC-POWR1014/A are all included in the larger ispPAC-POWR1220AT8 device, designs implemented in an ispPAC-POWR1014/A can be verified using an ispPAC-POWR1220AT8 engineering prototype board connected to the parallel port of a PC with a Lattice ispDOWNLOAD™ cable. The board demonstrates proper layout techniques and can be used in real time to check circuit operation as part of the design pro-

cess. Input and output connections are provided to aid in the evaluation of the functionality implemented in ispPAC-POWR1014/A for a given application. (Figure 2-29).

Figure 2-29. Download from a PC

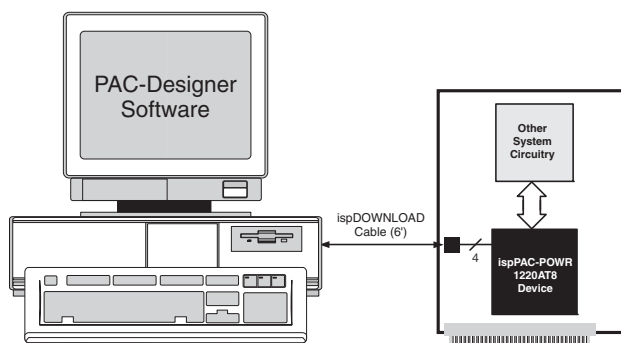

IEEE Standard 1149.1 Interface (JTAG)

Serial Port Programming Interface Communication with the ispPAC-POWR1014/A is facilitated via an IEEE 1149.1 test access port (TAP). It is used by the ispPAC-POWR1014/A as a serial programming interface. A brief description of the ispPAC-POWR1014/A JTAG interface follows. For complete details of the reference specification, refer to the publication, Standard Test Access Port and Boundary-Scan Architecture, IEEE Std 1149.1-1990 (which now includes IEEE Std 1149.1a-1993).

Overview

An IEEE 1149.1 test access port (TAP) provides the control interface for serially accessing the digital I/O of the ispPAC-POWR1014/A. The TAP controller is a state machine driven with mode and clock inputs. Given in the correct sequence, instructions are shifted into an instruction register, which then determines subsequent data input, data output, and related operations. Device programming is performed by addressing the configuration register, shifting data in, and then executing a program configuration instruction, after which the data is transferred to internal E²CMOS cells. It is these non-volatile cells that store the configuration of the ispPAC-POWR1014/A. A set of instructions are defined that access all data registers and perform other internal control operations. For compatibility between compliant devices, two data registers are mandated by the IEEE 1149.1 specification. Others are functionally specified, but inclusion is strictly optional. Finally, there are provisions for optional data registers defined by the manufacturer. The two required registers are the bypass and boundary-scan registers. Figure 2-30 shows how the instruction and various data registers are organized in an ispPAC-POWR1014/A.

Figure 2-30. ispPAC-POWR1014/A TAP Registers

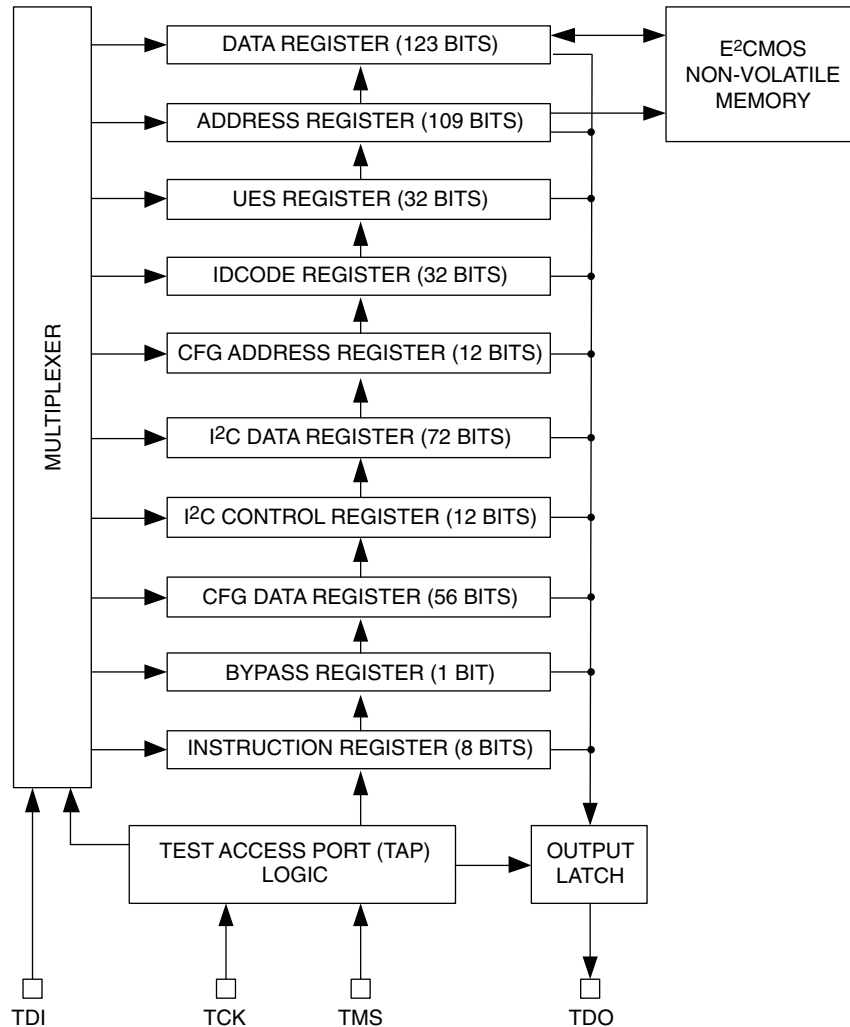

TAP Controller Specifics

The TAP is controlled by the Test Clock (TCK) and Test Mode Select (TMS) inputs. These inputs determine whether an Instruction Register or Data Register operation is performed. Driven by the TCK input, the TAP consists of a small 16-state controller design. In a given state, the controller responds according to the level on the TMS input as shown in Figure 2-31. Test Data In (TDI) and TMS are latched on the rising edge of TCK, with Test Data Out (TDO) becoming valid on the falling edge of TCK. There are six steady states within the controller: Test-Logic-Reset, Run- Test/Idle, Shift-Data-Register, Pause-Data-Register, Shift-Instruction-Register and Pause-Instruction-Register. But there is only one steady state for the condition when TMS is set high: the Test-Logic-Reset state. This allows a reset of the test logic within five TCKs or less by keeping the TMS input high. Test-Logic-Reset is the power-on default state.

Figure 2-31. TAP States

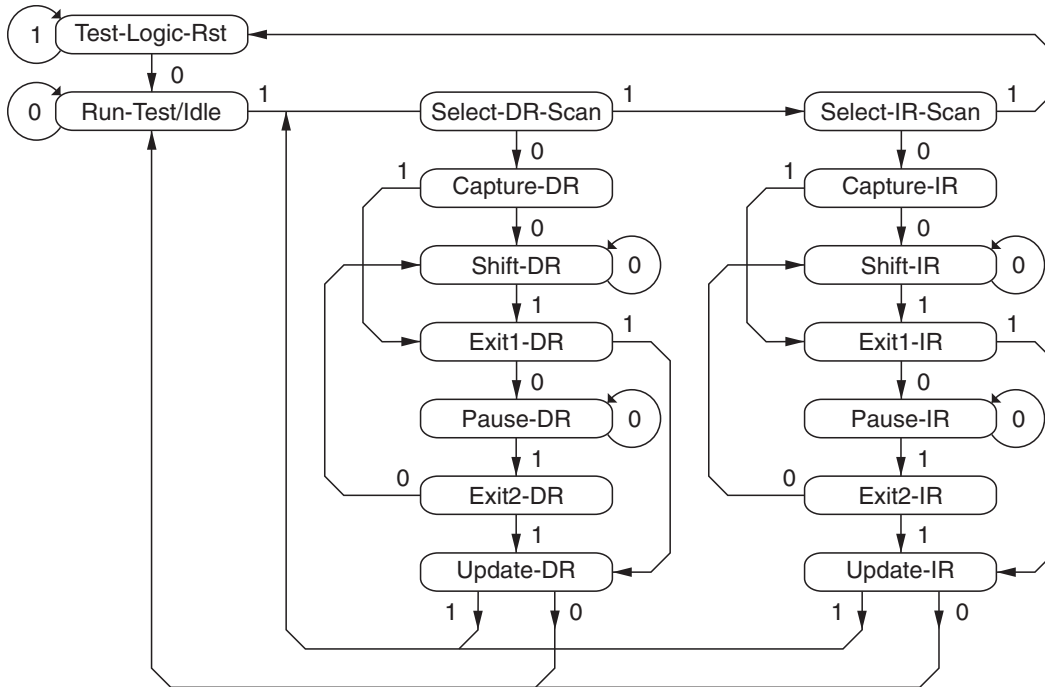

Note: The value shown adjacent to each state transition in this figure represents the signal present at TMS at the time of a rising edge at TCK.

When the correct logic sequence is applied to the TMS and TCK inputs, the TAP will exit the Test-Logic-Reset state and move to the desired state. The next state after Test-Logic-Reset is Run-Test/Idle. Until a data or instruction shift is performed, no action will occur in Run-Test/Idle (steady state = idle). After Run-Test/Idle, either a data or instruction shift is performed. The states of the Data and Instruction Register blocks are identical to each other differing only in their entry points. When either block is entered, the first action is a capture operation. For the Data Registers, the Capture-DR state is very simple: it captures (parallel loads) data onto the selected serial data path (previously chosen with the appropriate instruction). For the Instruction Register, the Capture-IR state will always load the IDCODE instruction. It will always enable the ID Register for readout if no other instruction is loaded prior to a Shift-DR operation. This, in conjunction with mandated bit codes, allows a “blind” interrogation of any device in a compliant IEEE 1149.1 serial chain. From the Capture state, the TAP transitions to either the Shift or Exit1 state. Normally the Shift state follows the Capture state so that test data or status information can be shifted out or new data shifted in. Following the Shift state, the TAP either returns to the Run-Test/Idle state via the Exit1 and Update states or enters the Pause state via Exit1. The Pause state is used to temporarily suspend the shifting of data through either the Data or Instruction Register while an external operation is performed. From the Pause state, shifting can resume by reentering the Shift state via the Exit2 state or be terminated by entering the Run-Test/Idle state via the Exit2 and Update states. If the proper instruction is shifted in during a Shift-IR operation, the next entry into Run-Test/Idle initiates the test mode (steady state = test). This is when the device is actually programmed, erased or verified. All other instructions are executed in the Update state.

Test Instructions

Like data registers, the IEEE 1149.1 standard also mandates the inclusion of certain instructions. It outlines the function of three required and six optional instructions. Any additional instructions are left exclusively for the manufacturer to determine. The instruction word length is not mandated other than to be a minimum of two bits, with only the BYPASS and EXTEST instruction code patterns being specifically called out (all ones and all zeroes respectively). The ispPAC-POWR1014/A contains the required minimum instruction set as well as one from the optional instruction set. In addition, there are several proprietary instructions that allow the device to be configured and ver-

ified. Table 2-11 lists the instructions supported by the ispPAC-POWR1014/A JTAG Test Access Port (TAP) controller.

Table 2-11. ispPAC-POWR1014/A TAP Instruction Table

Instruction	Command Code	Comments
BULK_ERASE	0000 0011	Bulk erase device
BYPASS	1111 1111	Bypass - connects TDO to TDI
DISCHARGE	0001 0100	Fast VPP discharge
ERASE_DONE_BIT	0010 0100	Erases 'Done' bit only
I2C_DATA_REGISTER	0010 0101	Accessing I ² C data register through JTAG (72 bits)
I2C_CONTROL_REGISTER	0010 0110	Controls read and write functions of I ² C registers (12 bits)
EXTEST	0000 0000	Bypass - connect TDO to TDI
IDCODE	0001 0110	Read contents of manufacturer ID code (32 bits)
OUTPUTS_HIGHZ	0001 1000	Force all outputs to High-Z state, FET outputs pulled low
SAMPLE/PRELOAD	0001 1100	Sample/Preload. Default to bypass.
PROGRAM_DISABLE	0001 1110	Disable program mode
PROGRAM_DONE_BIT	0010 1111	Programs the Done bit
PROGRAM_ENABLE	0001 0101	Enable program mode
PROGRAM_SECURITY	0000 1001	Program security fuse
RESET	0010 0010	Resets device (refer to the RESETb Signal, RESET Command via JTAG or I2C section of this data sheet)
IN1_RESET_JTAG_BIT	0001 0010	Reset the JTAG bit associated with IN1 pin to 0
IN1_SET_JTAG_BIT	0001 0011	Set the JTAG bit associated with IN1 pin to 1
CFG_ADDRESS	0010 1011	Select non-PLD address register
CFG_DATA_SHIFT	0010 1101	Non-PLD data shift
CFG_ERASE	0010 1001	ERASE just the non-PLD configuration
CFG_PROGRAM	0010 1110	Non-PLD program
CFG_VERIFY	0010 1000	VERIFY non-PLD fusemap data
PLD_ADDRESS_SHIFT	0000 0001	PLD_Address register (109 bits)
PLD_DATA_SHIFT	0000 0010	PLD_Data register (123 bits)
PLD_INIT_ADDR_FOR_PROG_INCR	0010 0001	Initialize the address register for auto increment
PLD_PROG_INCR	0010 0111	Program column register to E ² and auto increment address register
PLD_PROGRAM	0000 0111	Program PLD data register to E ²
PLD_VERIFY	0000 1010	Verifies PLD column data
PLD_VERIFY_INCR	0010 1010	Load column register from E ² and auto increment address register
UES_PROGRAM	0001 1010	Program UES bits into E ²
UES_READ	0001 0111	Read contents of UES register from E ² (32 bits)

BYPASS is one of the three required instructions. It selects the Bypass Register to be connected between TDI and TDO and allows serial data to be transferred through the device without affecting the operation of the ispPAC-POWR1014/A. The IEEE 1149.1 standard defines the bit code of this instruction to be all ones (11111111).

The required **SAMPLE/PRELOAD** instruction dictates the Boundary-Scan Register be connected between TDI and TDO. The ispPAC-POWR1014/A has no boundary scan register, so for compatibility it defaults to the BYPASS mode whenever this instruction is received. The bit code for this instruction is defined by Lattice as shown in Table 2-11.

The **EXTEST** (external test) instruction is required and would normally place the device into an external boundary test mode while also enabling the boundary scan register to be connected between TDI and TDO. Again, since the ispPAC-POWR1014/A has no boundary scan logic, the device is put in the BYPASS mode to ensure specification compatibility. The bit code of this instruction is defined by the 1149.1 standard to be all zeros (00000000).

The optional **IDCODE** (identification code) instruction is incorporated in the ispPAC-POWR1014/A and leaves it in its functional mode when executed. It selects the Device Identification Register to be connected between TDI and TDO. The Identification Register is a 32-bit shift register containing information regarding the IC manufacturer, device type and version code (Figure 2-32). Access to the Identification Register is immediately available, via a TAP data scan operation, after power-up of the device, or by issuing a Test-Logic-Reset instruction. The bit code for this instruction is defined by Lattice as shown in Table 2-11.

Figure 2-32. ispPAC-POWR1014/A ID Code

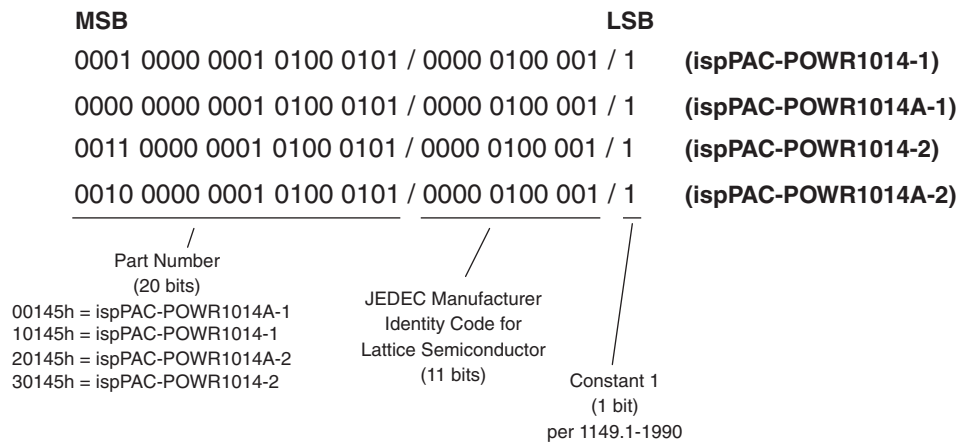

ispPAC-POWR1014/A Specific Instructions

There are 25 unique instructions specified by Lattice for the ispPAC-POWR1014/A. These instructions are primarily used to interface to the various user registers and the E²CMOS non-volatile memory. Additional instructions are used to control or monitor other features of the device. A brief description of each unique instruction is provided in detail below, and the bit codes are found in Table 2-11.

PLD_ADDRESS_SHIFT – This instruction is used to set the address of the PLD AND/ARCH arrays for subsequent program or read operations. This instruction also forces the outputs into the OUTPUTS_HIGHZ.

PLD_DATA_SHIFT – This instruction is used to shift PLD data into the register prior to programming or reading. This instruction also forces the outputs into the OUTPUTS_HIGHZ.

PLD_INIT_ADDR_FOR_PROG_INCR – This instruction prepares the PLD address register for subsequent PLD_PROG_INCR or PLD_VERIFY_INCR instructions.

PLD_PROG_INCR – This instruction programs the PLD data register for the current address and increments the address register for the next set of data.

PLD_PROGRAM – This instruction programs the selected PLD AND/ARCH array column. The specific column is preselected by using PLD_ADDRESS_SHIFT instruction. The programming occurs at the second rising edge of the TCK in Run-Test-Idle JTAG state. The device must already be in programming mode (PROGRAM_ENABLE instruction). This instruction also forces the outputs into the OUTPUTS_HIGHZ.

PROGRAM_SECURITY – This instruction is used to program the electronic security fuse (ESF) bit. Programming the ESF bit protects proprietary designs from being read out. The programming occurs at the second rising edge of the TCK in Run-Test-Idle JTAG state. The device must already be in programming mode (PROGRAM_ENABLE instruction). This instruction also forces the outputs into the OUTPUTS_HIGHZ.

PLD_VERIFY – This instruction is used to read the content of the selected PLD AND/ARCH array column. This specific column is preselected by using PLD_ADDRESS_SHIFT instruction. This instruction also forces the outputs into the OUTPUTS_HIGHZ.

DISCHARGE – This instruction is used to discharge the internal programming supply voltage after an erase or programming cycle and prepares ispPAC-POWR1014/A for a read cycle. This instruction also forces the outputs into the OUTPUTS_HIGHZ.

CFG_ADDRESS – This instruction is used to set the address of the CFG array for subsequent program or read operations. This instruction also forces the outputs into the OUTPUTS_HIGHZ.

CFG_DATA_SHIFT – This instruction is used to shift data into the CFG register prior to programming or reading. This instruction also forces the outputs into the OUTPUTS_HIGHZ.

CFG_ERASE – This instruction will bulk erase the CFG array. The action occurs at the second rising edge of TCK in Run-Test-Idle JTAG state. The device must already be in programming mode (PROGRAM_ENABLE instruction). This instruction also forces the outputs into the OUTPUTS_HIGHZ.

CFG_PROGRAM – This instruction programs the selected CFG array column. This specific column is preselected by using CFG_ADDRESS instruction. The programming occurs at the second rising edge of the TCK in Run-Test-Idle JTAG state. The device must already be in programming mode (PROGRAM_ENABLE instruction). This instruction also forces the outputs into the OUTPUTS_HIGHZ.

CFG_VERIFY – This instruction is used to read the content of the selected CFG array column. This specific column is preselected by using CFG_ADDRESS instruction. This instruction also forces the outputs into the OUTPUTS_HIGHZ.

BULK_ERASE – This instruction will bulk erase all E²CMOS bits (CFG, PLD, UES, and ESF) in the ispPAC-POWR1014/A. The device must already be in programming mode (PROGRAM_ENABLE instruction). This instruction also forces the outputs into the OUTPUTS_HIGHZ.

OUTPUTS_HIGHZ – This instruction turns off all of the open-drain output transistors. Pins that are programmed as FET drivers will be placed in the active low state. This instruction is effective after Update-Instruction-Register JTAG state.

PROGRAM_ENABLE – This instruction enables the programming mode of the ispPAC-POWR1014/A. This instruction also forces the outputs into the OUTPUTS_HIGHZ.

IDCODE – This instruction connects the output of the Identification Code Data Shift (IDCODE) Register to TDO (Figure 2-33), to support reading out the identification code.

Figure 2-33. IDCODE Register

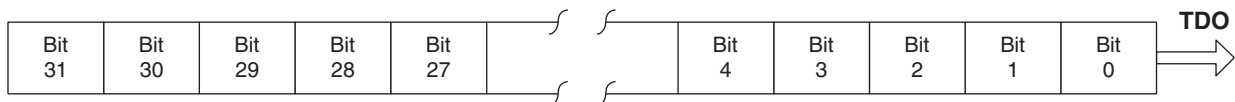

PROGRAM_DISABLE – This instruction disables the programming mode of the ispPAC-POWR1014/A. The Test-Logic-Reset JTAG state can also be used to cancel the programming mode of the ispPAC-POWR1014/A.

UES_READ – This instruction both reads the E²CMOS bits into the UES register and places the UES register between the TDI and TDO pins (as shown in Figure 2-30), to support programming or reading of the user electronic signature bits.

Figure 2-34. UES Register

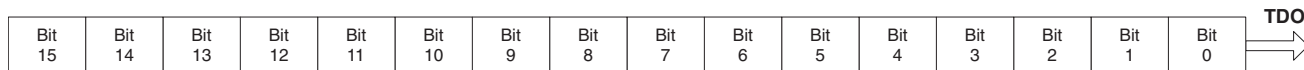

UES_PROGRAM – This instruction will program the content of the UES Register into the UES E²CMOS memory. The device must already be in programming mode (PROGRAM_ENABLE instruction). This instruction also forces the outputs into the OUTPUTS_HIGHZ.

ERASE_DONE_BIT – This instruction clears the 'Done' bit, which prevents the ispPAC-POWR1014/A sequence from starting.

PROGRAM_DONE_BIT – This instruction sets the 'Done' bit, which enables the ispPAC-POWR1014/A sequence to start.

RESET – This instruction resets the PLD sequence and output macrocells.

IN1_RESET_JTAG_BIT – This instruction clears the JTAG Register logic input 'IN1.' The PLD input has to be configured to take input from the JTAG Register in order for this command to have effect on the sequence.

IN1_SET_JTAG_BIT – This instruction sets the JTAG Register logic input 'IN1.' The PLD input has to be configured to take input from the JTAG Register in order for this command to have effect on the sequence.

PLD_VERIFY_INCR – This instruction reads out the PLD data register for the current address and increments the address register for the next read.

Notes:

In all of the descriptions above, OUTPUTS_HIGHZ refers both to the instruction and the state of the digital output pins, in which the open-drains are tri-stated and the FET drivers are pulled low.

Before any of the above programming instructions are executed, the respective E²CMOS bits need to be erased using the corresponding erase instruction.

Accessing I²C Registers through JTAG (ispPAC-POWR1014A Only)

I²C registers can be read or written through the JTAG interface of the ispPAC-POWR1014A devices using the two JTAG command codes shown in Table 2-12.

Note: The SCL pin of the I²C port should be pulled high during the entire time that the I²C registers are being accessed via the JTAG port.

Table 2-12. JTAG Command Codes

Instruction	Command Code	Comments
I2C_DATA_REGISTER	0010 0101	Accessing I ² C Data Register Through JTAG (72 Bits)
I2C_CONTROL_REGISTER	0010 0110	Controls Read and Write Functions of I ² C Registers (12 Bits)

There are 12 bits in the I2C_Control_Register and 72 bits in the I2C_Data_Register packet. All I²C register contents, except the UES bits, can be read out through the 72-bit I2C_Data_Register packet. All I²C write registers can be written by shifting in a 72-bit I2C_Data_Register packet. The I2C_Control_Register bits are used to select the I²C registers read as well as written.

The reading (shifting out) and writing (shifting in) of I2C_Data_Register and writing of the I2C_Control_Register through the JTAG port follows the TAP states protocol shown in Figure 2-31.

I2C_Control_Register Structure

Figure 2-35 shows the functions of each of the 12-bit I2C_Control_Register bits.

Figure 2-35. I2C_Control_Register

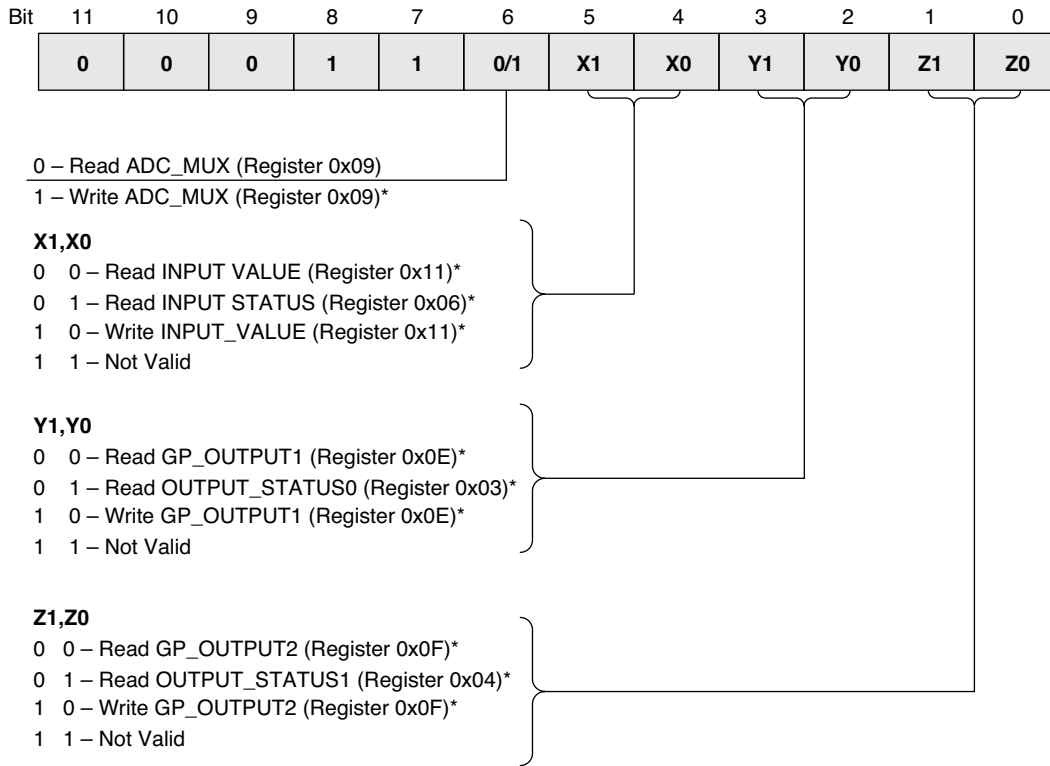

*Equivalent I²C port addresses are shown in parentheses.

I2C_Data_Register Packet Structure

The 72-bit I2C_Data_Register packet is divided into 9 bytes.

- Bytes 9-7 contain the VMON status
- Bytes 6-5 contain ADC result
- Byte 4 controls/reads ADC Mux and ADC Input Attenuator
- Byte 3 controls/reads input pins/ status
- Bytes 2-1 control/read output pins/status

VMON Status Registers

Byte 9, Byte 8 and Byte 7: Byte 9 is the most significant byte and is shifted out last, ending with bit 71, VMON1A. These bytes consist of the status of VMONxA and VMONxB comparators corresponding to VMON1 through VMON10 inputs. In the following tables, the number in the parenthesis indicates the bit position within the I2C_Data_Register Packet. During the I2C_Data_Register write operation, the contents of these bytes are ignored because the VMON status registers are read only.

Figure 2-36. VMON Status Registers

Byte 9 – VMON_STATUS0 (Read Only, Most Significant), I²C Address = 0x00

VMON1A (71)	VMON1B (70)	VMON2A (69)	VMON2B (68)	VMON3A (67)	VMON3B (66)	VMON4A (65)	VMON4B (64)
----------------	----------------	----------------	----------------	----------------	----------------	----------------	----------------

Byte 8 – VMON_STATUS1 (Read Only), I²C Address = 0x01

VMON5A (63)	VMON5B (62)	VMON6A (61)	VMON6B (60)	VMON7A (59)	VMON7B (58)	VMON8A (57)	VMON8B (56)
----------------	----------------	----------------	----------------	----------------	----------------	----------------	----------------

Byte 7 – VMON_STATUS2 (Read Only), I²C Address = 0x02

VMON9A (55)	VMON9B (54)	VMON10A (53)	VMON10B (52)	1 (51)	1 (50)	1 (49)	1 (48)
----------------	----------------	-----------------	-----------------	-----------	-----------	-----------	-----------

ADC Interface Registers

Byte 6, Byte 5: These bytes contain 12-bit ADC measured values.

Figure 2-37. ADC Interface Registers, Bytes 6 and 5

Byte 6 – ADC_Value_Low (Read Only), I²C Address = 0x07

X (47)	1 (46)	1 (45)	1 (44)	D0 (43)	D1 (42)	D2 (41)	D3 (40)
-----------	-----------	-----------	-----------	------------	------------	------------	------------

Byte 5 – ADC_Value_High (Read Only), I²C Address = 0x08

D4 (39)	D5 (38)	D6 (37)	D7 (36)	D8 (35)	D9 (34)	D10 (33)	D11 (32)
------------	------------	------------	------------	------------	------------	-------------	-------------

Byte 4: The I2C_Data_Register write operation action is determined by bit 6 of the I2C_Control_Register. When bit 6 of the I2C_Control_Register is set to 1, this byte selects the VMON input for routing to the ADC (4-bit ADC input mux) and sets/clears the ADC attenuate mode. When the bit 6 of the I2C_Control_register is reset to 0, the contents of the Byte 4 are ignored. During I2C_Data_Register read operation with bit 6 reset to 0 in the I2C_Control_Register, byte 4 returns the 4-bit input mux setting and the attenuate bit setting. Refer to Tables 2-8 and 2-9 for the mux select and the attenuate bits decode value.

Figure 2-38. ADC Interface Registers, Byte 4

Byte 4 – ADC_MUX (Read/ Write), I²C Address = 0x09

SEL0 (31)	SEL1 (30)	SEL2 (29)	SEL3 (28)	ATTEN (27)	X (26)	X (25)	X (24)
--------------	--------------	--------------	--------------	---------------	-----------	-----------	-----------

Digital Input Status and Input Value Register

Byte 3: I2C_Control_Register bits 5 and 4 control reading into and writing from Byte 3 of the I2C_Data_Register. When bits 5 and 4 are set to 10b, the contents of Byte 3 are written into the input register bits during the I2C_Data_Register write operation.

Figure 2-39. INPUT_VALUE Registers, Byte 3

Byte 3 – INPUT_VALUE (Write Operation) – When I2C_Control_Register bit 5 =1, bit 4=0, I²C Address = 0x11

X (23)	I2 (22)	I3 (21)	I4 (20)	1 (19)	1 (18)	1 (17)	1 (16)
-----------	------------	------------	------------	-----------	-----------	-----------	-----------

During the I2C_Data_Register read operation - When I2C_Control_Register bit 5 = 0, and bit 4 = 0, the Byte 3 value will return INPUT_VALUE register.

Byte 3 – INPUT_VALUE (Read operation) – When I2C_Control_Register Bit 5=0 and Bit 4=0, I2C Address = 0x11

X (23)	I2 (22)	I3 (21)	I4 (20)	1 (19)	1 (18)	1 (17)	1 (16)
-----------	------------	------------	------------	-----------	-----------	-----------	-----------

During the I2C_Data_Register read operation - When I2C_Control_Register bit 5 = 0, and bit 4 = 1 Byte 3 value will return INPUT_STATUS register.

Byte 3 – INPUT_STATUS (Read operation) – When I2C_Control_Register Bit 5=0 and Bit 4=1, I2C Address = 0x06

X (23)	IN2 (22)	IN3 (21)	IN4 (20)	1 (19)	1 (18)	1 (17)	1 (16)
-----------	-------------	-------------	-------------	-----------	-----------	-----------	-----------

Output Status and GP_Output Registers

Byte 2, Byte 1: These bytes control the digital outputs and HVOUT outputs during the write operation. The Output Status and GP_Output register association with the outputs are shown in Figure 2-21. During the write operation, the Gp_Output 1 and Gp_Output 2 registers are written with values specified in Byte 2 and Byte 1, when the I2C_Control_Register bits 3 and 2 are set to 0x10b and bits 1 and 0 are set to 0x10b. During the I2C_Data_Register read operation (I2C_Control_Register bits 3 and 2 = 0x00b and bits 1 and 0 = 0x00b), Byte 2 and Byte 1 return the GP_Output registers. If I2C_Control_Register bits 3 and 2 = 0x01b and bits 1 and 0 = 0x01b, Byte 2 and Byte 1 will return the OUTPUT STATUS registers.

Figure 2-40. Output Status and GP_Output Registers, Byte 2

Byte 2 – GP_OUTPUT1 (Write operation) – When I2C_Control_Register Bit 3 =1, Bit 2=0, I2C Address = 0x0E

GP1 (15)	GP2 (14)	GP3_ENb (13)	GP4 (12)	GP5 (11)	GP6 (10)	GP7 (9)	GP8 (8)
-------------	-------------	-----------------	-------------	-------------	-------------	------------	------------

Byte 2 – GP_OUTPUT1 (Read Operation) – When I2C_Control_Register Bit 3 =0, Bit 2=0, I2C Address = 0x0E

GP1 (15)	GP2 (14)	GP3_ENb (13)	GP4 (12)	GP5 (11)	GP6 (10)	GP7 (9)	GP8 (8)
-------------	-------------	-----------------	-------------	-------------	-------------	------------	------------

Byte 2 – OUTPUT_STATUS0 (Read Operation) – When I2C_Control_Register Bit 3 =0, Bit 2=1, I2C Address = 0x03

HVOUT1 (15)	HVOUT2 (14)	OUT3 (13)	OUT4 (12)	OUT5 (11)	OUT6 (10)	OUT7 (9)	OUT8 (8)
----------------	----------------	--------------	--------------	--------------	--------------	-------------	-------------

Figure 2-41. Output Status and GP_Output Registers, Byte 1

Byte 1 – GP_OUTPUT2 (Write Operation) – When I2C_Control_Register Bit 1=1, Bit 0=0, I2C Address = 0x0F

GP9 (7)	GP10 (6)	GP11 (5)	GP12 (4)	GP13 (3)	GP14 (2)	X (1)	X (0)
------------	-------------	-------------	-------------	-------------	-------------	----------	----------

Byte 1 – GP_OUTPUT2 (Read Operation) – When I2C_Control_Register Bit 1=0, Bit 0=0, I2C Address = 0x0F

GP9 (7)	GP10 (6)	GP11 (5)	GP12 (4)	GP13 (3)	GP14 (2)	X (1)	X (0)
------------	-------------	-------------	-------------	-------------	-------------	----------	----------

Byte 1 – OUTPUT_STATUS1 (Read Operation) – When I2C_Control_Register Bit 1=0, Bit 0=1, I2C Address = 0x04

OUT9 (7)	OUT10 (6)	OUT11 (5)	OUT12 (4)	OUT13 (3)	OUT14 (2)	1 (1)	1 (0)
-------------	--------------	--------------	--------------	--------------	--------------	----------	----------

JTAG Access Method Example

This example shows various steps required to measure the voltage applied to the VMON5 of the ispPAC-POWR1014A device. These steps include transition through the TAP states shown in Figure 2-31. This example assumes that 5V is applied to VMON5.

Figure 2-42. VMON5 JTAG Access Example

```

TRST ON;
TRST OFF;
! --- I2C Control Register
SIR 8 TDI (26);
! --- Set Bit 6 for ADC_MUX Register Write
SDR 12 TDI (040);
STATE IDLE;
! --- end I2C Control Register

! --- I2C Data Register Write ADC convert
SIR 8 TDI (25);
! --- Set ADC Attenuate
! --- Set VMON Select Bits [3:0] to VMON5
SDR 72 TDI (000000000028000000);
! --- Wait 100us for ADC conversion
RUNTEST 1000 TCK;
STATE IDLE;
! --- end I2C Data Register Write ADC Convert

! --- I2C Data Register Read
SDR 72 TDI (xxxxxxxxxxxxxxxxxxxx) TDO (xxxxxxxxxxxxxxxxxxxx);
STATE IDLE;
! --- end I2C Data Register Read
    
```

Table 2-13 shows the bit values of 72-bit I2C_Data_Register packet after POR.

Table 2-13. I2C_Data_Register Packet Reset Values

JTAG Byte	Equivalent I ² C Register Address	Register Name	Read/Write	Description	Value After POR ¹
9	0x00	vmon_status0	R	VMON input status Vmon[1:4]	---- ----
8	0x01	vmon_status1	R	VMON input status Vmon[5:8]	---- ----
7	0x02	vmon_status2	R	VMON input status Vmon[9:10]	---- XXXX
2	0x03	output_status0	R	Output status HVOUT[1:2], OUT[3:8],	---- ----
1	0x04	output_status1	R	Output status OUT[9:14]	XX -- ----
3	0x06	input_status	R	Input Status IN[2:4]	X --- XXXX
6	0x07	adc_value_low	R	ADC D[0:3]	XXXX ----
5	0x08	adc_value_high	R	ADC D[4:11]	---- -- XX
4	0x09	adc_mux	R/W	ADC Mux[0:3] & Attenuator	0000 0XXX
2	0x0E	gp_output1	R/W	GPOUT[1:8]	0000 0100
1	0x0F	gp_output2	R/W	GPOUT[9:14]	0000 00XX
3	0x11	Input_value	R/W	PLD Input Register [2:4]	X 000 XXXX

1. "X" = Non-functional bit (bits read out as 1's).
 "-" = State depends on device configuration of input status.

Package Diagrams

48-Pin TQFP (Dimensions in Millimeters)

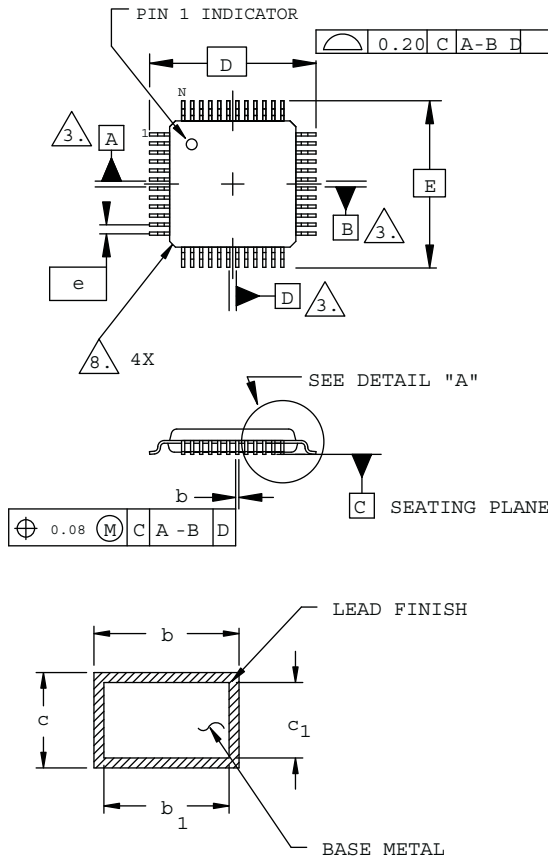

SECTION B - B

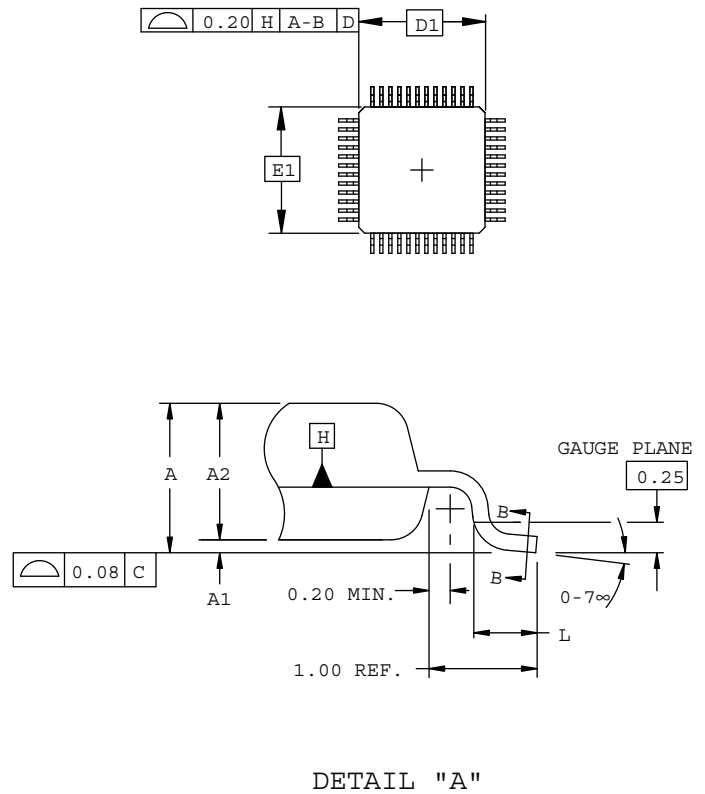

DETAIL "A"

NOTES:

1. DIMENSIONING AND TOLERANCING PER ANSI Y14.5 - 1982.
2. ALL DIMENSIONS ARE IN MILLIMETERS.
3. DATUMS A, B AND D TO BE DETERMINED AT DATUM PLANE H.
4. DIMENSIONS D1 AND E1 DO NOT INCLUDE MOLD PROTRUSION. ALLOWABLE MOLD PROTRUSION IS 0.254 MM ON D1 AND E1 DIMENSIONS.
5. THE TOP OF PACKAGE MAY BE SMALLER THAN THE BOTTOM OF THE PACKAGE BY 0.15 MM.
6. SECTION B-B:
THESE DIMENSIONS APPLY TO THE FLAT SECTION OF THE LEAD BETWEEN 0.10 AND 0.25 MM FROM THE LEAD TIP.
7. A1 IS DEFINED AS THE DISTANCE FROM THE SEATING PLANE TO THE LOWEST POINT ON THE PACKAGE BODY.
8. EXACT SHAPE OF EACH CORNER IS OPTIONAL.

SYMBOL	MIN.	NOM.	MAX.
A	-	-	1.60
A1	0.05	-	0.15
A2	1.35	1.40	1.45
D	9.00 BSC		
D1	7.00 BSC		
E	9.00 BSC		
E1	7.00 BSC		
L	0.45	0.60	0.75
N	48		
e	0.50 BSC		
b	0.17	0.22	0.27
b1	0.17	0.20	0.23
c	0.09	0.15	0.20
c1	0.09	0.13	0.16

Part Number Description

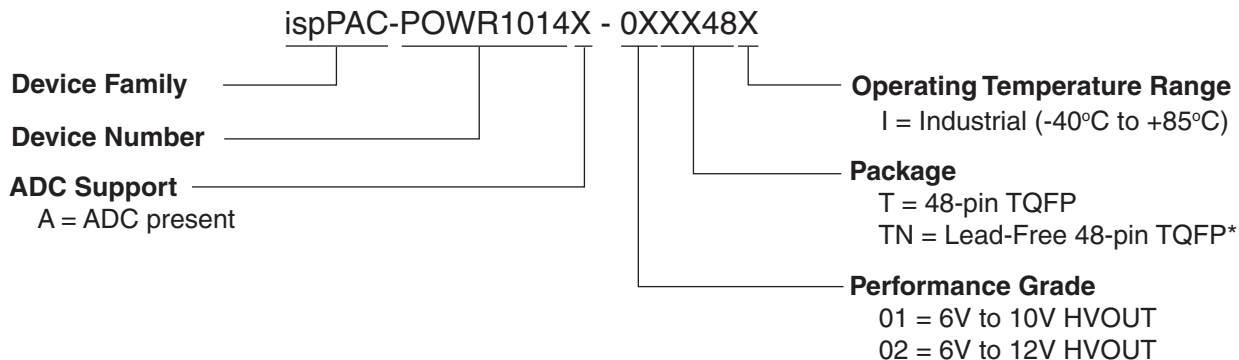

ispPAC-POWR1014/A Ordering Information

Conventional Packaging

Part Number	Package	Pins
ispPAC-POWR1014A-01T48I	TQFP	48
ispPAC-POWR1014-01T48I	TQFP	48
ispPAC-POWR1014A-02T48I	TQFP	48
ispPAC-POWR1014-02T48I	TQFP	48

Lead-Free Packaging

Part Number	Package	Pins
ispPAC-POWR1014A-01TN48I	Lead-Free TQFP	48
ispPAC-POWR1014-01TN48I	Lead-Free TQFP	48
ispPAC-POWR1014A-02TN48I	Lead-Free TQFP	48
ispPAC-POWR1014-02TN48I	Lead-Free TQFP	48

Package Options

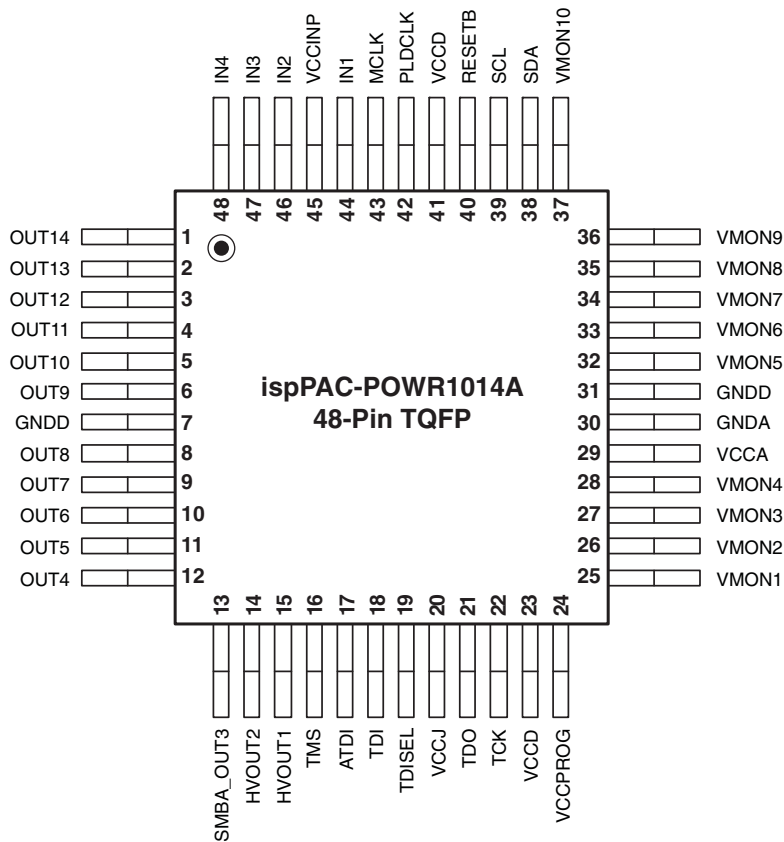

Package Options (Cont.)

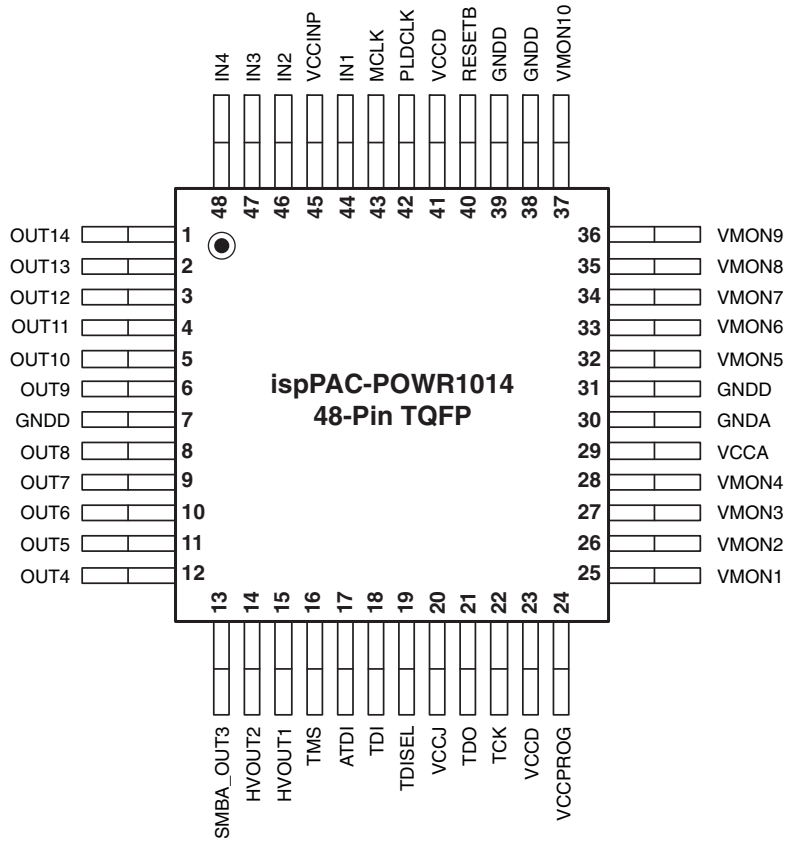

Technical Support Assistance

Hotline: 1-800-LATTICE (North America)
+1-503-268-8001 (Outside North America)

e-mail: isppacs@latticesemi.com

Internet: www.latticesemi.com

Revision History

Date	Version	Change Summary
February 2006	01.0	Initial release.
March 2006	01.1	ispPAC-POWR1014/A block diagram: "SELTDI" changed to "TDISEL".
		Pin Descriptions table: "InxP" changed to "Inx", "MONx" to "VMONx", VMON upper range from "5.75V" to "5.87V".
		Pin Descriptions table, note 4 - clarification for un-used VMON pins to be tied to GNDD.
		Absolute Maximum Ratings table and Recommended Operating Conditions table: "VMON+" changed to VMON".
		Digital Specifications table: add note # 2 to ISINKTOTAL: "Sum of maximum current sink by all digital outputs. Reliable operation is not guaranteed if this value is exceeded."
		Typographical corrections: Vmon trip points and thresholds
		Typographical corrections: "InxP" to "Inx", "MONx" to "VMONx".
May 2006	01.2	Update HVOOUT I source range: 12.5 μ A to 100 μ A
		Clarify operation of ADC conversions
		Digital Specifications table, added footnotes on I ² C frequency
		TAP Instructions table, clarify DISCHARGE instruction of JTAG. Added instruction descriptions for others.
October 2006	01.3	Data sheet status changed to "Final"
		Analog Specifications table, reduced Max. I _{CC} to 20 mA.
		Tightened Input Resistor Variation to 15%.
		AC/Transient Characteristics table, tightened Internal Oscillator frequency variation down to 5%.
		Digital Specifications table, included V _{IL} and V _{IH} specifications for I ² C interface.
March 2007	01.4	Corrected VCCINP Voltage range from "2.25V to 3.6V" to "2.25V to 5.5V".
		Removed reference to Internal Pull-up resistor for signal line TDO.
		Corrected the Maximum Vmon Range value from 5.734V to 5.867V.
		Removed references to VPS[0:1].
August 2007	01.5	Changes to HVOOUT pin specifications.
June 2008	01.6	Added timing diagram and timing parameters to "Power-On Reset" specifications.
		Modified PLD Architecture figure to show input registers.
		Updated I ² C Control Registers table.
		V _{CCPROG} pin usage clarification added.
November 2009	01.7	V _{CCPROG} pin usage further clarified.
		Added Accessing I ² C Registers Through JTAG section.
		Added product information for the ispPAC-POWR1014-02 and ispPAC-POWR1014A-02.