

## Introduction

Synchronous DRAM (SDRAM) has become a mainstream memory of choice in embedded system memory design due to its speed, burst access and pipeline features. For high-end applications using processors such as Motorola MPC 8260 or Intel StrongArm, the interface to the SDRAM is supported by the processor's built-in peripheral module. However, for other applications, the system designer must design a controller to provide proper commands for SDRAM initialization, read/write accesses and memory refresh. In some cases, SDRAM is chosen because the previous generations of DRAM (FP and EDO) are either end-of-life or not recommended for new designs by the memory vendors. From the board design point of view, design using earlier generations of DRAM is much easier and more straightforward than using SDRAM unless the system bus master provides the SDRAM interface module as mentioned above. This SDRAM controller reference design, located between the SDRAM and the bus master, reduces the user's effort to deal with the SDRAM command interface by providing a simple generic system interface to the bus master. Figure 1 shows the relationship of the controller between the bus master and SDRAM. The bus master can be either a microprocessor or a user's proprietary module interface.

In today's SDRAM market, there are two major types of SDRAM distinguished by their data transfer rates. The most common single data rate (SDR) SDRAM transfers data on the rising edge of the clock. The other is the double data rate (DDR) SDRAM which transfers data on both the rising and falling edge to double the data transfer throughput. Other than the data transfer phase, the different power-on initialization and mode register definitions, these two SDRAMs share the same command set and basic design concepts. This reference design is targeted for SDR SDRAM, however, due to the similarity of SDR and DDR SDRAM, this design can also be modified for a DDR SDRAM controller. For illustration purposes, the Micron SDR SDRAM MT48LC32M4A2 (8Meg x 4 x 4 banks) is chosen for this design. Also, this design has been verified by using Micron's simulation model. It is highly recommended to download the simulation model from the SDRAM vendors for timing simulation when any modifications are made to this design.

**Figure 1. SDR SDRAM Controller System**

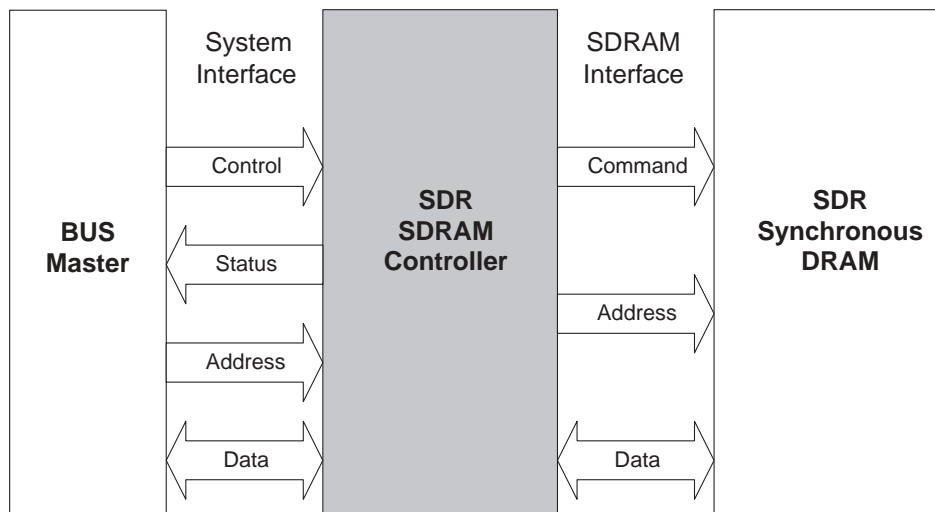

## Features

- Simplifies SDRAM command interface to standard system read/write interface.
- Internal state machine built for SDRAM power-on initialization.
- Read/write cycle access time optimized automatically according to the SDRAM timing spec and the mode it's configured to.

- Dedicated auto-refresh request input and acknowledge output for SDRAM refresh.
- Easily configurable to support different CAS latency and burst length.
- Supports ispMACH 5000VG and other Lattice CPLD devices.
- By taking advantage of the ispMACH 5000VG CPLD sysCLOCK feature, a slower system clock can be used. The system interface clock does not need to be the same as the SDRAM clock.
- By taking advantage of the ispMACH 5000VG CPLD sysIO feature, the system interface can be in any I/O standards supported by this feature.

## Pin Descriptions

Pin Name	Type	Pin Description
sys_R_Wn	In	System interface read/write signal. High indicates a read cycle and low indicates a write cycle. When this pin is high, it indicates to the controller that the bus master is performing a read cycle. When low, it indicates that it's a write cycle.
sys_ADStn	In	Active low system interface address strobe. This pin indicates the start of a bus master cycle.
sys_DLY_100US	In	This active high signal indicates to the controller that the SDRAM has gone through the 100 $\mu$ s delay for power and clock stabilization.
sys_CK	In	System interface clock.
sys_RESET	In	This active high signal resets the controller to the initial state.
sys_REF_REQ	In	Active high SDRAM refresh request.
sys_REF_ACK	Out	Active high SDRAM refresh acknowledge
sys_A	In	System interface address bus.
sys_D	In/Out	Bi-directional three-state system interface data bus.
sys_D_VALID	Out	Active high data valid signal. This pin activates only for read cycles and indicates the data currently present on the system interface data bus sys_D is valid.
sys_CYC_END	Out	This active high signal indicates to the bus master that the system interface read/write cycle is completed. This pin is active after reset. After that, it is negated at the first clock and asserted at the last clock of the system interface read/write cycle.
sys_INIT_DONE	Out	This active high signal indicates that the SDRAM initialization is completed.
sdr_DQ	In/Out	SDRAM data bus
sdr_A	Out	SDRAM address bus
sdr_BA	Out	SDRAM bank address
sdr_CK	Out	SDRAM clock (If PLL is used, this will be the PLL output pin PLL_OUT0 or PLL_OUT1.)
sdr_CKE	Out	SDRAM clock enable
sdr_CS#	Out	SDRAM command inputs CS#
sdr_RAS#	Out	SDRAM command inputs RAS#
sdr_CAS#	Out	SDRAM command inputs CAS#
sdr_Wen	Out	SDRAM command inputs WE#
sdr_DQM	Out	SDRAM data bus mask

## Functional Description

The functional block diagram of the SDRAM controller is shown in Figure 2. It consists of three modules: the main control module, the signal generation module and the data path module. The main control module, containing two state machines and a counter, is the primary module of the design which generates proper iState and cState outputs according to the system interface control signals. The signal generation module generates the address and command signals required for SDRAM based on iState and cState. The data path module performs the data latching and dispatching of the data between the bus master and SDRAM.

When targeting to ispMACH 5000VG, the reference design takes advantage of the ispMACH 5000VG sysCLOCK and sysIO features. All modules derive internal timing from the ispMACH 5000VG's PLL clock output. This PLL clock also outputs through a dedicated ispMACH 5000VG pin (PLL\_OUT0 or PLL\_OUT1) and can be connected to

the SDRAM directly. So, a separate on-board SDRAM clock may not be required. With the ispMACH 5000VG sysIO feature, the bus master I/O can be LVCMOS 1.8/2.5/3.3, LVTTTL, SSTL\_2, SSTL\_3, PCI, PCI-X, GTL+, AGP or 5V tolerance. There is no minimum speed grade requirement for ispMACH 5000VG devices to implement this design. However, a higher maximum clock frequency will be achieved by using ispMACH 5000VG with faster speed grade.

When targeting to other Lattice CPLD devices, instead of generating SDRAM clock by the CPLD, the system needs the on-board clock source such as clock oscillator to generate clock for both the CPLD and the SDRAM.

Figure 2. Block Diagram

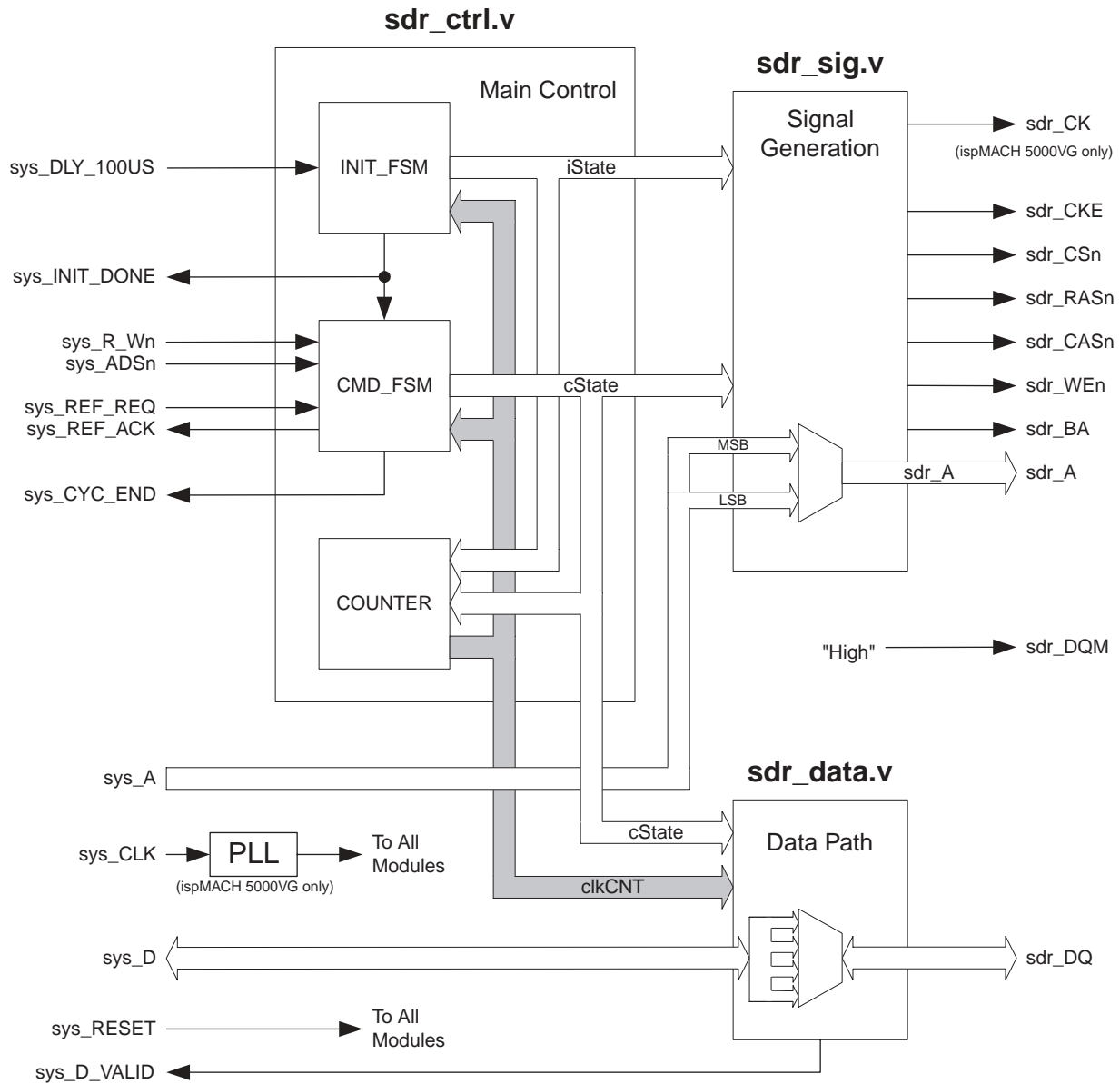

### Benefits of Using PLL

As mentioned in the functional description section above, the SDRAM clock can be generated by the internal PLL of ispMACH 5000VG devices. For example, if the system is running at 40MHz, a 100MHz SDRAM clock can be obtained through the dedicated PLL output pin by setting the proper PLL attributes (multiply = 5 and divide = 2). Please refer to the ispMACH 5000VG Family data sheet for the PLL attributes and the pin locations of PLL\_OUT0 and PLL\_OUT1.

---

Also, by using the PLL's variable delay line capability, all the output signals to the SDRAM can be tuned to retard or advance the normal output timing for timing optimization and system reliability improving.

## SDRAM Initialization

Before normal memory accesses can be performed, the SDRAM needs to be initialized by a sequence of commands. The INIT\_FSM state machine handles this initialization. Figure 3 shows the state diagram of the INIT\_FSM state machine. During reset, the INIT\_FSM is forced to the i\_NOP state. After reset, the sys\_100 $\mu$ s signal will be sampled at the rising edge of every PLL clock cycle to determine if the 100 $\mu$ s power/clock stabilization delay is completed. After the power/clock stabilization is complete, the SDRAM initialization sequence will begin and the INIT\_FSM will switch from i\_NOP to i\_PRE state. The initialization starts with the PRECHARGE command, followed by two AUTO REFRESH commands, and then the LOAD MODE REGISTER command to configure SDRAM to a specific mode of operation. The i\_PRE, i\_AR1, i\_AR2 and i\_MRS states are used for issuing these commands. After each of these commands is issued, a corresponding timing delay needs to be satisfied before any command other than NOP can be issued. These timing delays are  $t_{RP}$ ,  $t_{RFC}$  and  $t_{MRD}$  for command PRECHARGE, AUTO REFRESH and LOAD MODE REGISTER respectively. After issuing the LOAD MODE REGISTER command and the  $t_{MRD}$  timing delay is satisfied, INIT\_FSM goes to i\_ready state and remains there for the normal memory access cycles unless sys\_RESET is asserted. Also, signal sys\_INIT\_DONE is set to high to indicate the SDRAM initialization is completed.

The LOAD MODE REGISTER command configures the SDRAM by loading data into the mode register through the address bus. The data present on the address bus during the LOAD MODE REGISTER command is loaded to the mode register. The mode register contents specify the burst length, burst type, CAS latency, etc. Refer to the SDRAM vendor's data sheet for more detailed information about the mode register field definitions. As long as all banks of the SDRAM are put into idle state by the PRECHARGE or AUTO PRECHARGE, the mode register can be reloaded with different values, thereby changing the mode of operation. However, in most applications, the mode register value will not be changed after the initialization. This design assumes the mode register stays the same after initialization and a fixed mode register content is implemented in the HDL code. The mode register content in the HDL code may need to be modified to suit the user's needs.

Figure 3. INIT\_FSM State Diagram

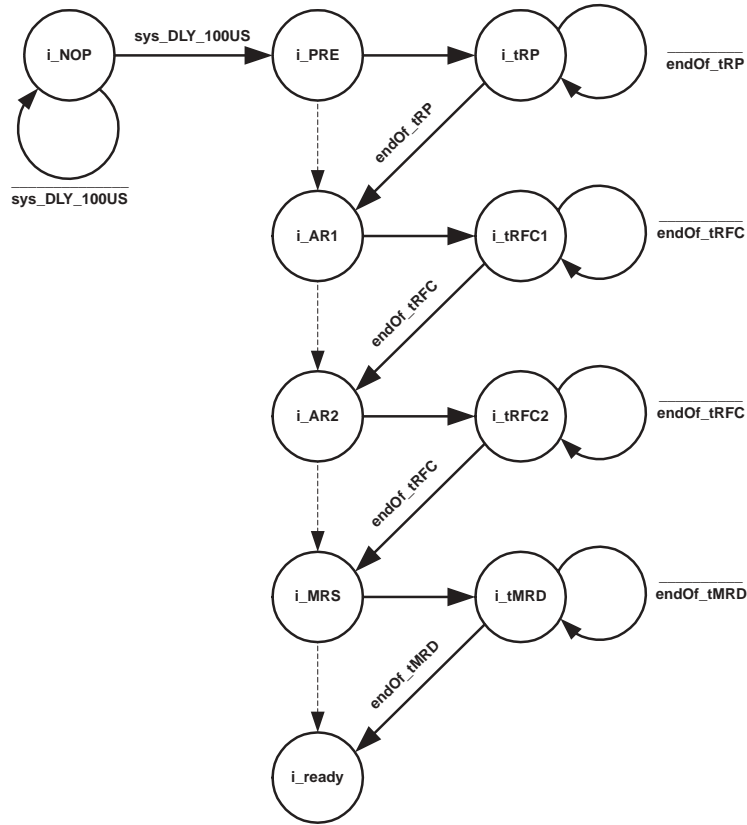

As mentioned above, certain timing delays ( $t_{RP}$ ,  $t_{RFC}$ ,  $t_{MRD}$ ) need to be satisfied before another non-NOP command can be issued. These SDRAM delays vary from speed grade to speed grade and sometimes from vendor to vendor. To accommodate this without sacrificing performance, the designer needs to modify the HDL code for the specific delays and clock period ( $t_{CK}$ ). According to these timing values, the number of clocks the state machine will stay at  $i_{tRP}$ ,  $i_{tRFC1}$ ,  $i_{tRFC2}$ ,  $i_{tMRD}$  states will be determined after the code is synthesized. In cases where  $t_{CK}$  is larger than the timing delay, the state machine doesn't need to switch to the timing delay states and can go directly to the command states. The dashed lines in Figure 3 show the possible state switching paths.

### Read/Write Cycle

Figure 4 shows the state diagram of CMD\_FSM which handles the read, write and refresh of the SDRAM. The CMD\_FSM state machine is initialized to  $c\_idle$  during reset. After reset, CMD\_FSM stays in  $c\_idle$  as long as  $sys\_INIT\_DONE$  is low which indicates the SDRAM initialization sequence is not yet completed. Once the initialization is done,  $sys\_ADS_n$  and  $sys\_REF\_REQ$  will be sampled at the rising edge of every clock cycle. A logic high sampled on  $sys\_REF\_REQ$  will start a SDRAM refresh cycle. This is described in the following section. If logic low is sampled on both  $sys\_REF\_REQ$  and  $sys\_ADS_n$ , a system read cycle or system write cycle will begin. These system cycles are made up of a sequence of SDRAM commands.

Figure 4. CMD\_FSM State Diagram

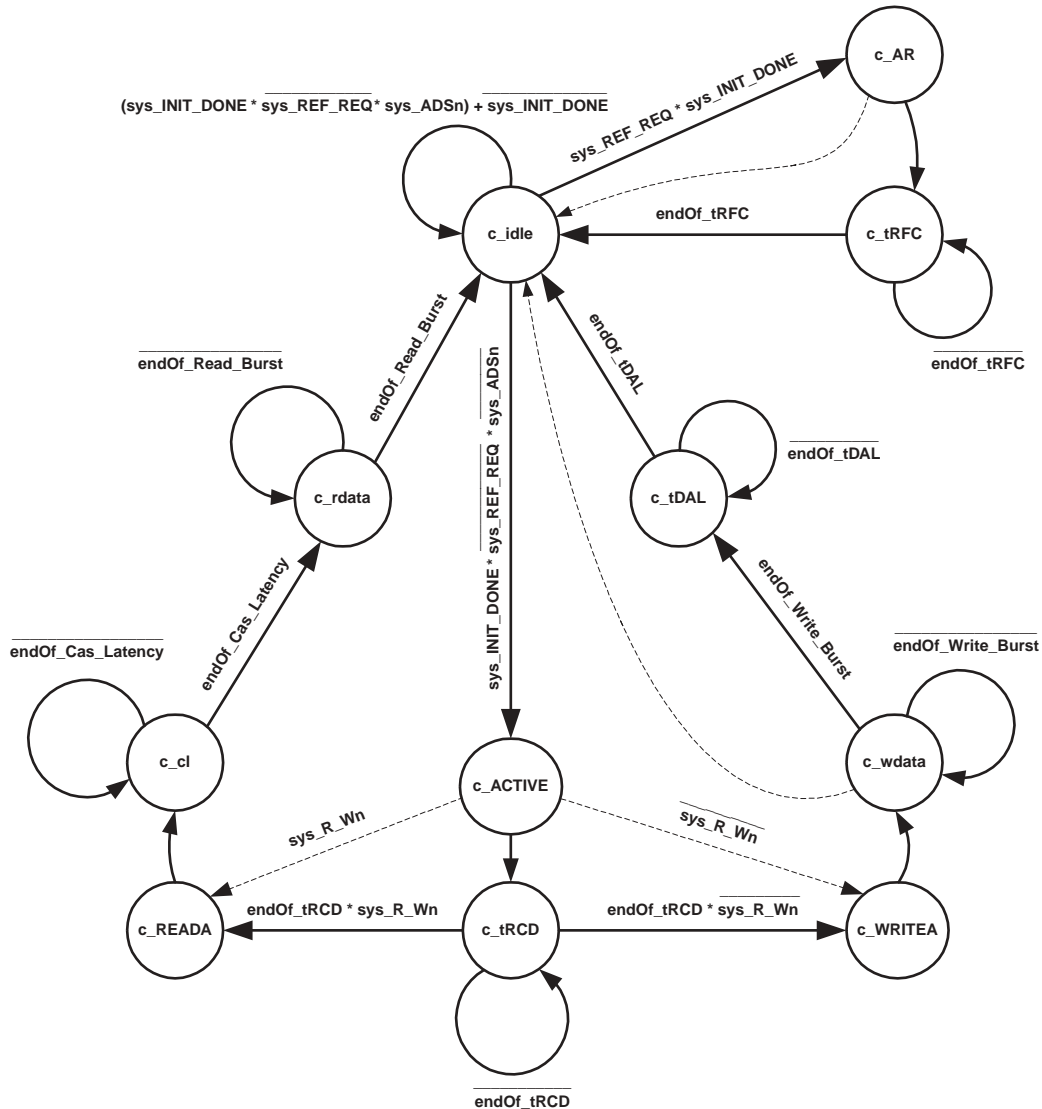

Similar to the FP and EDO DRAM, row address and column address are required to pinpoint the memory cell location of the SDRAM access. Since SDRAM is composed of four banks, bank address needs to be provided as well.

The SDRAM can be considered as a four by N array of rows. All rows are in the “closed” status after the SDRAM initialization. The rows need to be “opened” before they can be accessed. However, only one row in the same bank can be opened at a time. Since there are four banks, there can be at most four rows opened at the same time. If a row in one bank is currently opened, it must be closed before another row in the same bank can be opened. ACTIVE command is used to open the rows and PRECHARGE (or the AUTO PRECHARGE hidden in the WRITE and READ commands, as used in this design) is used to close the rows. When issuing the commands for opening or closing the rows, both row address and bank address need to be provided.

For sequential access applications and those with page memory management, the proper address assignments and the use of the SDRAM pipeline feature deliver the highest performance SDRAM controller. However, this type of controller design is highly associated with the bus master cycle specification and will not fit the general applications. Therefore, this SDRAM controller design does not implement these custom features to achieve the highest performance through these techniques.

In this design, the ACTIVE command will be issued for each read or write access to open the row. After a  $t_{RCD}$  delay is satisfied, READ or WRITE commands will be issued with a high `sdr_A[10]` to enable the AUTO REFRESH for closing the row after access. So, the clocks required for read/write cycle are fixed and the access can be random over the full address range.

Read or write is determined by the `sys_R_Wn` status sampled at the rising edge of the clock before  $t_{RCD}$  delay is satisfied. If a logic high is sampled, the state machine switches to `c_READA`. If a logic low is sampled, the state machine switches to `c_WRITEA`.

For read cycles, the state machine switches from `c_READA` to `c_cl` for CAS latency, then switches to `c_rdata` for transferring data from SDRAM to bus master. The number of clocks the state machine stays in `c_rdata` state is determined by the burst length. After the data is transferred, it switches back to `c_idle`.

For write cycles, the state machine switches from `c_WRITEA` to `c_wdata` for transferring data from bus master to SDRAM, then switches to `c_tDAL`. Similar to read, the number of clocks the state machine stays in `c_wdata` state is determined by the burst length. The time delay  $t_{DAL}$  is the sum of WRITE recovery time  $t_{WR}$  and the AUTO PRE-CHARGE timing delay  $t_{RP}$ . After the clock rising edge of the last data in the burst sequence, no commands other than NOP can be issued to SDRAM before  $t_{DAL}$  is satisfied.

As mentioned in the INIT\_FSM section above, the dash lines indicates possible state switching paths when  $t_{CK}$  period is larger than timing delay spec.

## Refresh Cycle

Similar to the other DRAMs, memory refresh is required. A SDRAM refresh request is generated by activating `sdr_REF_REQ` signal of the controller. The `sdr_REF_ACK` signal will acknowledge the recognition of `sdr_REF_REQ` and will be active throughout the whole refresh cycle. The `sdr_REF_REQ` signal must be maintained until the `sdr_REF_ACK` goes active in order to be recognized as a refresh cycle. Note that no system read/write access cycles are allowed when `sdr_REF_ACK` is active. All system interface cycles will be ignored during this period. The `sdr_REF_REQ` signal assertion needs to be removed upon receipt of `sdr_REF_ACK` acknowledge, otherwise another refresh cycle will again be performed.

Upon receipt of `sdr_REF_REQ` assertion, the state machine CMD\_FSM enters the `c_AR` state to issue an AUTO REFRESH command to the SDRAM. After  $t_{RFC}$  time delay is satisfied, CMD\_FSM returns to `c_idle`.

## Data Path

Figure 5 shows the data flow design between the SDRAM and the system interface. The module in this reference design interfaces between the SDRAM with 4-bit data bus and the bus master with 16-bit data bus. The user should be able to modify this module to customize to fit his/her system bus requirements.

The size of each bus in Figure 5 is shown by the number under the slash across the bus. The grayed components are for read cycles and the white components are for write cycles.

Figure 5. Data Path Module

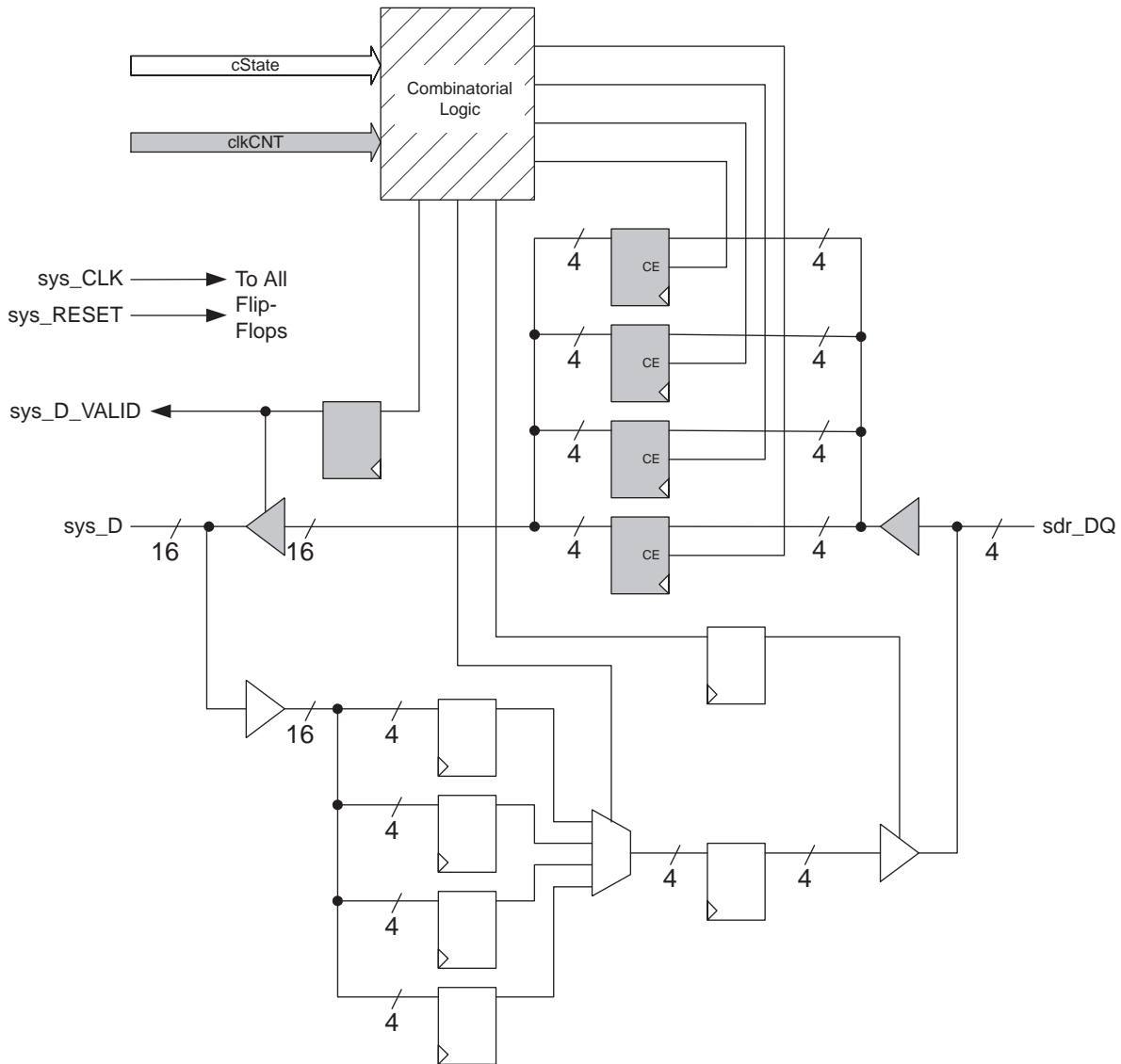

### Timing Diagrams

Figures 6 and 7 are the read cycle and write cycle timing diagrams of the reference design with the two CAS latency cycles and the burst length of four. The timing diagrams may be different due to the values of the timing delays  $t_{MRD}/t_{RP}/t_{RFC}/t_{RCD}/t_{RCD}/t_{WR}$ , the clock period  $t_{CK}$ , the CAS latency and the burst length. The total number of clocks for read and write cycles are decided by these factors. In the example shown in the figures, the read cycle takes 10 clocks and the write cycle takes 9 clocks.

The state variable  $c\_State$  of  $CMD\_FSM$  is also shown in these figures. Note that the ACTIVE, READ, WRITE commands are asserted one clock after the  $c\_ACTIVE$ ,  $c\_READA$ ,  $c\_WRITEA$  states respectively.

The values of the region filled with slashes in the system interface input signals of these figures are “don’t care.” For example, signal  $sys\_R\_Wn$  needs to be valid only at the clock before  $CMD\_FSM$  switches to the  $c\_READA$  or  $c\_WRITEA$  states. Depending on the values of  $t_{RCD}$  and  $t_{CK}$ , this means the signal  $sys\_R\_Wn$  needs to be valid at state  $c\_ACTIVE$  or the last clock of state  $c\_tRCD$ .

Figure 6. Read Cycle Timing Diagram

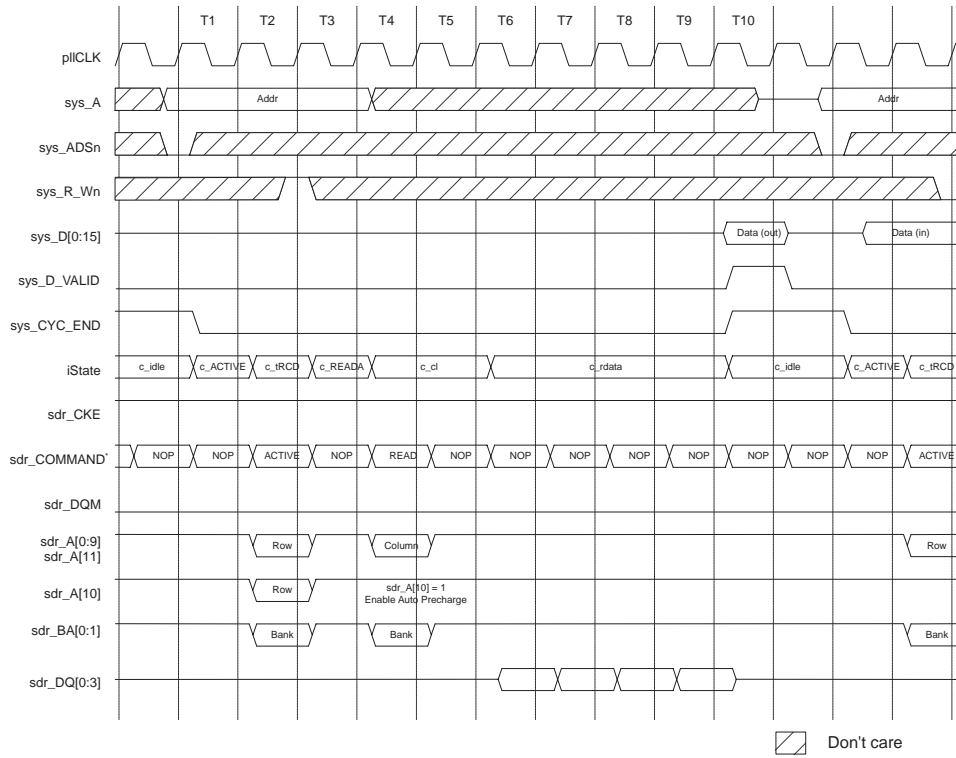
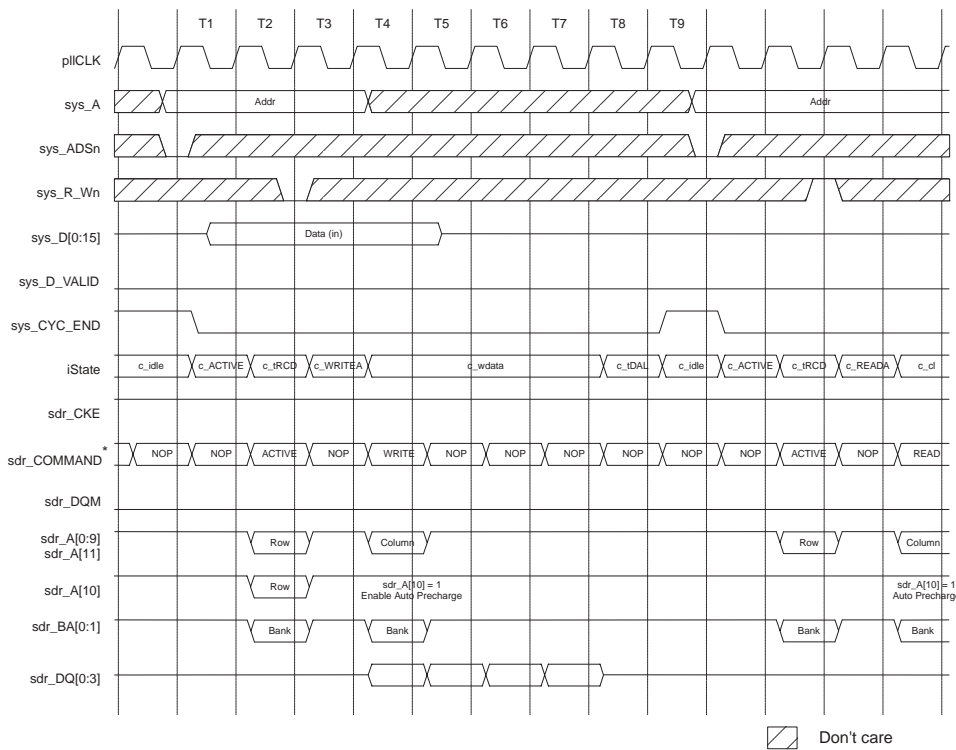

Figure 7. Write Cycle Timing Diagram



## Implementation

This design is implemented in Verilog HDL language. The relationship between the source code and test bench is shown in Figure 8. The software used for this implementation is the Lattice ispLEVER™ design tool with LeonardoSpectrum synthesis selected, using default settings.

Device	Macrocells Used	GLB Level	Max. Clock Freq*
LC51024VG-5F676ES	76	N/A	133.3 MHz
M4A3-192/96-6VC	73	N/A	147.1 MHz
ispLSI5128VE-180LT128	80	1	172 MHz

Note: The Max Clock Freq is obtained by running the Timing Analysis of Lattice Design Software. Please run the timing simulation after you make changes to this design or after you merge it with your design.

The Verilog source code and test fixture for this SDR SDRAM controller design are available from Lattice. Please contact your local Lattice sales office or Lattice FAE for details and to obtain the code.

**Figure 8. Relationship of Modules**

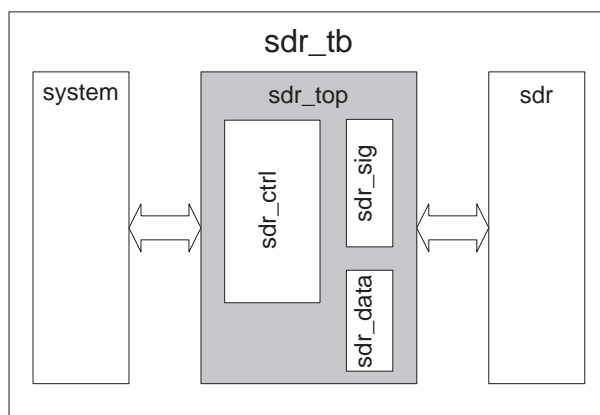

### Source code:

sdr\_5kvg\_top.v : Top level source code when using ispMACH 5000VG devices  
sdr\_top.v : Top level source code when using other Lattice CPLD devices  
sdr\_ctrl.v : Main control module  
sdr\_sig.v : Signal generation module  
sdr\_data.v : Data path module  
sdr\_para.v : Parameter definition

### Test fixture:

sdr\_5kvg\_tb.tf : Verilog test fixture when using ispMACH 5000VG devices  
sdr\_tb.tf : Verilog test fixture when using other Lattice CPLD devices

Note: The Verilog test fixture includes the following three modules:

- sdr\_tb : Main test bench
- sdr : SDR SDRAM simulation module (This design has been verified using Micron's SDR SDRAM simulation model. Once a memory device has been selected, this module can be replaced with a specific device simulation model which can be downloaded from most memory vendors' web sites).
- system : System interface stimulus module

### **Technical Support Assistance**

Hotline: 1-800-LATTICE (Domestic)  
1-408-826-6002 (International)  
e-mail: [techsupport@latticesemi.com](mailto:techsupport@latticesemi.com)