

Harvatek Surface Mount LED Data Sheet**HT-P318FCHU-ZZZZ**

Official Product	HT Part No. HT-P318FCHU-ZZZZ	Your Part No.		Data Sheet No.
Tentative Product	*****	*****		HT-P318FCHU-ZZZZ
Specifications are subject to changes for improvement without advance notice. Proprietary data, drawings, and company confidential all rights reserved.		March. 01, 2007	Version of 1.0	Page 1/19

DISCLAIMER.....3

PRODUCT SPECIFICATIONS.....4

DESCRIPTION OF PART NUMBER AND LOT NUMBER.....5

PART NUMBER.....5

LOT NUMBER.....5

PACKAGE DIMENSIONS AND RECOMMENDED SOLDERING PATTERN.....6

ABSOLUTE MAXIMUM RATINGS.....7

ELECTRO-OPTICAL CHARACTERISTICS.....7

LUMINOUS FLUX RANK.....8

DOMINANT WAVELENGTH RANK.....8

FORWARD VOLTAGE RANK.....10

RADIATION PATTERN.....10

CHARACTERISTICS CURVES (RED).....11

CHARACTERISTICS CURVES (GREEN).....12

CHARACTERISTICS CURVES (BLUE).....13

TUBE AND PACKING.....14

TUBE DIMENSION.....14

PACKING MODEL.....14

PRECAUTIONS.....15

REFLOW SOLDERING.....16

REWORKING.....17

CLEANING.....17

STORAGE.....17

RELIABILITY TEST.....18

REVISION HISTORY.....19

Official Product	HT Part No. HT-P318FCHU-ZZZZ	Your Part No.		Data Sheet No.
Tentative Product	*****	*****		HT-P318FCHU-ZZZZ
Specifications are subject to changes for improvement without advance notice. Proprietary data, drawings, and company confidential all rights reserved.		March. 01, 2007	Version of 1.0	Page 2/19

Disclaimer

HARVATEK reserves the right to make changes without further notice to any products herein to improve reliability, function or design. HARVATEK does not assume any liability arising out of the application or use of any product or circuit described herein; neither does it convey any license under its patent rights, nor the rights of others.

Life Support Policy

HARVATEK's products are not authorized for use as critical components in life support devices or systems without the express written approval of the President of HARVATEK or HARVATEK INTERNATIONAL. As used herein:

1. Life support devices or systems are devices or systems which, (a) are intended for surgical implant into the body, or (b) support or sustain life, and (c) whose failure to perform when properly used in accordance with instructions for use provided in the labeling, can be reasonably expected to result in a significant injury of the user.

2. A critical component in any component of a life support device or system whose failure to perform can be reasonably expected to cause the failure of the life support device or system, or to affect its safety or effectiveness.

Official Product	HT Part No. HT-P318FCHU-ZZZZ	Your Part No.		Data Sheet No.
Tentative Product	*****	*****		HT-P318FCHU-ZZZZ
Specifications are subject to changes for improvement without advance notice. Proprietary data, drawings, and company confidential all rights reserved.		March. 01, 2007	Version of 1.0	Page 3/19

Product Specifications

	Specification	Material	Quantity
Total Flux	Red: 20lm typical @300mA/ Ta= 25°C, ± 10% Green: 25lm typical @350mA/ Ta= 25°C, ± 10% Blue: 11lm typical @350mA/ Ta= 25°C, ± 10%		
Dominant Wavelength	Red: 625nm typical @300mA/ Ta= 25°C, ± 0.5nm Green: 525nm typical @350mA/ Ta= 25°C, ± 0.5nm Blue: 470nm typical @350mA/ Ta= 25°C, ± 0.5nm		
V _F	Green, blue: 3.03-3.99V @350mA/ Ta=25°C, ± 0.1 V Red: 2.07-2.79V @300mA/ Ta=25°C, ± 0.1 V		
I _R	HT standard		
Resin	Clear	Epoxy resin	
Tube	HT standard	Conductive	50pcs per tube
Label	HT standard	Paper	
Carton	HT standard	Paper	Non-specified

ATTENTION: Electric Static Discharge (ESD) protection



The symbol to the left denotes that ESD precaution is needed. ESD protection for GaP and AlGaAs based chips is necessary even though they are relatively safe in the presence of low static-electric discharge. Parts built with AlInGaP, GaN, or/and InGaN based chips are **STATIC SENSITIVE devices**. ESD precaution must be taken during design and assembly.

If manual work or processing is needed, please ensure the device is adequately protected from ESD during the process.

Official Product	HT Part No. HT-P318FCHU-ZZZZ	Your Part No.		Data Sheet No.
Tentative Product	*****	*****		HT-P318FCHU-ZZZZ
Specifications are subject to changes for improvement without advance notice. Proprietary data, drawings, and company confidential all rights reserved.		March. 01, 2007	Version of 1.0	Page 4/19

Description of Part Number and Lot Number

Part Number

H T - P 3 1 8 XXX Y - Z Z Z Z

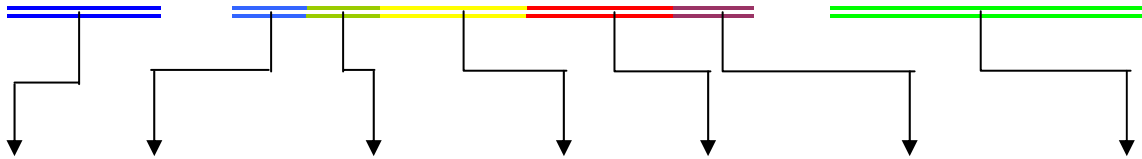

Company	Series Code	Dice / Power	Package Code	Emitter Color	Current Code	Customer Product Code
HT: Harvatek	P: Power F: Leadframe	1: One die 2: Two dice 3: Three dice ...	Outline dimension	FCH: RGB	T : 300mA U : 350mA	TBD

Lot Number

1 2 3 4 5 6 7 8 9 10
P 1 2 2 3 0 A - D T

Code 1	Code 2	Code 3	Code 4, 5	Code 6, 7	Code 9	Code 10
	Mfg. Year	Mfg. Month	Mfg. Date	Lots	Resin Color	Packaging
Internal Tracing Code	Z: 2000 1: 2001	1: Jan. 9: Sep. A: Oct.	1~31/ (30)	01~99, A,B,C...	D: Milky White C: Clear	T: Taped Reel

Official Product	HT Part No. HT-P318FCHU-ZZZZ	Your Part No.		Data Sheet No.
Tentative Product	*****	*****		HT-P318FCHU-ZZZZ
Specifications are subject to changes for improvement without advance notice. Proprietary data, drawings, and company confidential all rights reserved.		March. 01, 2007	Version of 1.0	Page 5/19

Package Dimensions and Recommended Soldering Pattern

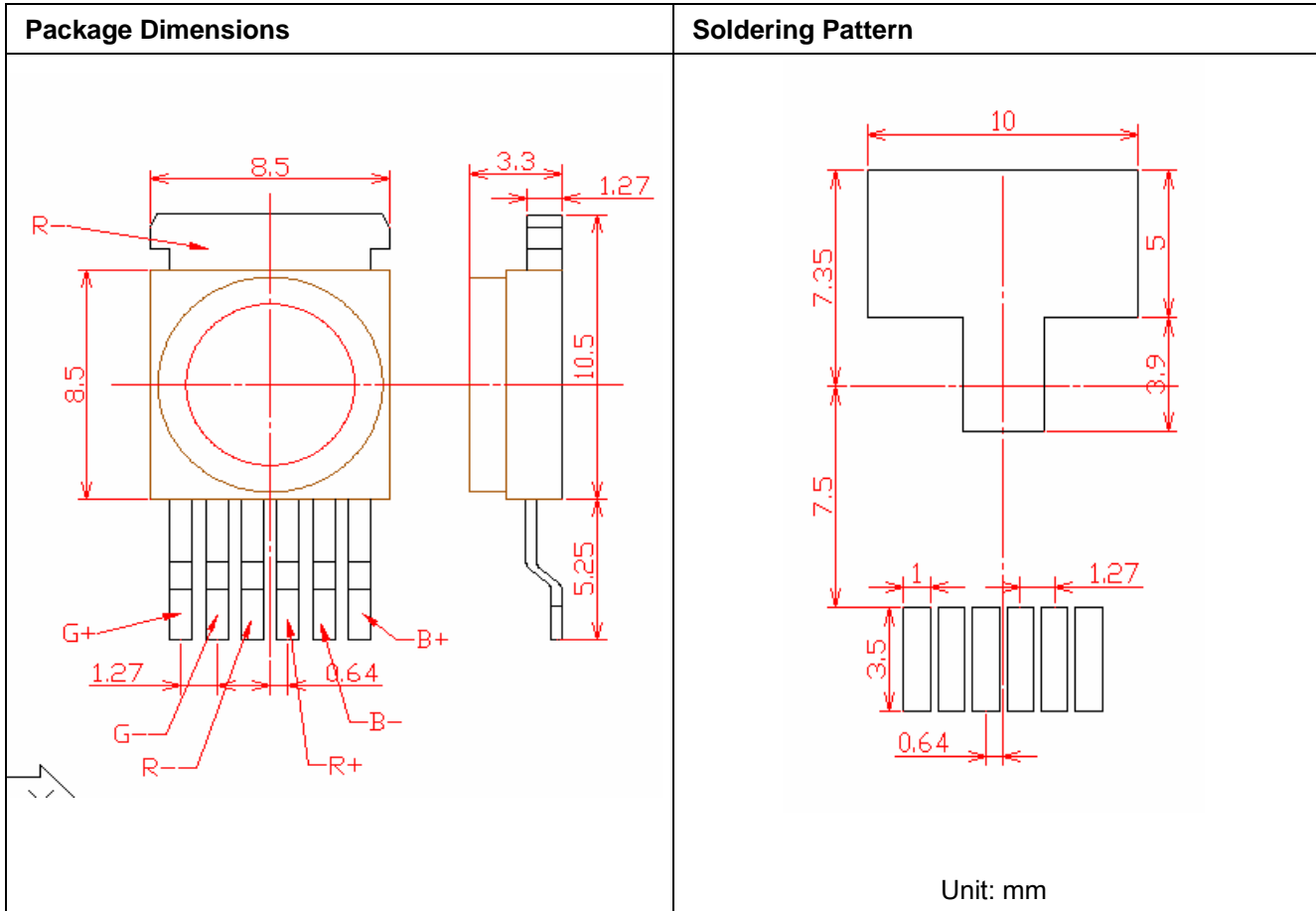

Tolerance: +/-0.1mm (unless otherwise noted)

Official Product	HT Part No. HT-P318FCHU-ZZZZ	Your Part No.		Data Sheet No.
Tentative Product	*****	*****		HT-P318FCHU-ZZZZ
Specifications are subject to changes for improvement without advance notice. Proprietary data, drawings, and company confidential all rights reserved.		March. 01, 2007	Version of 1.0	Page 6/19

Absolute Maximum Ratings

Parameter	Red	Green, Blue	Unit	Conditions ²
DC Forward Current	300	350	mA	-
Peak Pulsed Forward Current ¹	350	500	mA	-
Average Forward Current	300	350	mA	-
Reverse Voltage	5		V	-
LED Junction Temperature	120		°C	-
Operating Temperature	-30 ~ +85		°C	-
Storage Temperature	-40 ~ +120		°C	-
Soldering Temperature	260		°C	5 sec. Max.

¹ $t_p \leq 10\mu s$, Duty cycle=10%

² All at $T_a=25^\circ C$

Electro-Optical Characteristics

Parameter	Symbol	Color	Min.	Typ.	Max.	Unit	Condition ³
Forward Voltage	V_F	Green	3.03	-	3.99	V	$I_F=350mA$
		Blue	3.03	-	3.99	V	
		Red	2.07	-	2.79	V	$I_F=300mA$
Color	λ_D	Green	510	-	550	nm	$I_F=350mA$
		Blue	450	-	490	nm	
		Red	613.5	-	645	nm	$I_F=300mA$
Total Flux	Φ_v	Green	18.1	25	-	lm	$I_F=350mA$
		Blue	4.9	8	-	lm	
		Red	18.1	25	-	lm	$I_F=300mA$
View Angle	$2\theta^{1/2}$		-	110	-	°	-
Temperature Coefficient of Forward Voltage	$\Delta V_F/\Delta T$	Green	-	-2	-	mV/°C	-
		Blue	-	-2	-		
		Red	-	-2	-		
Thermal Resistance Junction to Board	$R\theta_{J-B}$	Red	-	11	-	°C/W	$I_F=300mA$
		Green	-	10	-		$I_F=350mA$
		Blue	-	10	-		

³ All at $T_a=25^\circ C$

λ_D represents Dominant Wavelength

Official Product	HT Part No. HT-P318FCHU-ZZZZ	Your Part No.		Data Sheet No.
Tentative Product	*****	*****		HT-P318FCHU-ZZZZ
Specifications are subject to changes for improvement without advance notice. Proprietary data, drawings, and company confidential all rights reserved.		March. 01, 2007	Version of 1.0	Page 7/19

Luminous Flux Rank

Rank Code	Symbol	Condition	Min.	Typ.	Max.	Unit
PF	ΦV	I _F =350mA (blue & green)	2.9	-	3.8	lm
PG			3.8	-	4.9	
PH			4.9	-	6.3	
PJ			6.3	-	8.2	
PK			8.2	-	10.7	
PL			10.7	-	13.9	
PM		I _F =300mA (red)	13.9	-	18.1	
PN			18.1	-	23.5	
PP			23.5	-	30.6	
PQ			30.6	-	39.8	
PR			39.8	-	51.7	

Tolerance: ±10%

Dominant Wavelength Rank

Red

Rank Code	Symbol	Condition	Min.	Typ.	Max.	Unit
Full	λ _D	I _F =300mA	613.5	-	645.0	nm
1			613.5	-	620.5	
2			620.5	-	631.0	
3			631.0	-	645.0	

Tolerance: ±0.5nm

Official Product	HT Part No. HT-P318FCHU-ZZZZ	Your Part No.		Data Sheet No.
Tentative Product	*****	*****		HT-P318FCHU-ZZZZ
Specifications are subject to changes for improvement without advance notice. Proprietary data, drawings, and company confidential all rights reserved.		March. 01, 2007	Version of 1.0	Page 8/19

Blue

Rank Code	Symbol	Condition	Min.	Typ.	Max.	Unit
Full	λ_D	$I_F=350mA$	450	-	490	nm
1			450	-	455	
2			455	-	460	
3			460	-	465	
4			465	-	470	
5			470	-	475	
6			475	-	480	
7			480	-	485	
8			485	-	490	

Tolerance: $\pm 0.5nm$

Green

Rank Code	Symbol	Condition	Min.	Typ.	Max.	Unit
Full	λ_D	$I_F=350mA$	510	-	550	nm
1			510	-	515	
2			515	-	520	
3			520	-	525	
4			525	-	530	
5			530	-	535	
6			535	-	540	
7			540	-	545	
8			545	-	550	

Tolerance: $\pm 0.5nm$

Official Product	HT Part No. HT-P318FCHU-ZZZZ	Your Part No.		Data Sheet No.
Tentative Product	*****	*****		HT-P318FCHU-ZZZZ
Specifications are subject to changes for improvement without advance notice. Proprietary data, drawings, and company confidential all rights reserved.		March. 01, 2007	Version of 1.0	Page 9/19

Forward Voltage Rank

Rank Code	Symbol	Condition	Min.	Typ.	Max.	Unit
Full	V _F	I _F =350mA (blue & green)	2.07	-	2.79	V
P01			2.07	-	2.31	
P02			2.31	-	2.55	
P03			2.55	-	2.79	
P04		I _F =300mA (red)	2.79	-	3.03	
P05			3.03	-	3.27	
P06			3.27	-	3.51	
P07			3.51	-	3.75	
P08			3.75	-	3.99	

Tolerance: ±0.1V

Radiation Pattern

Horizontal

Vertical

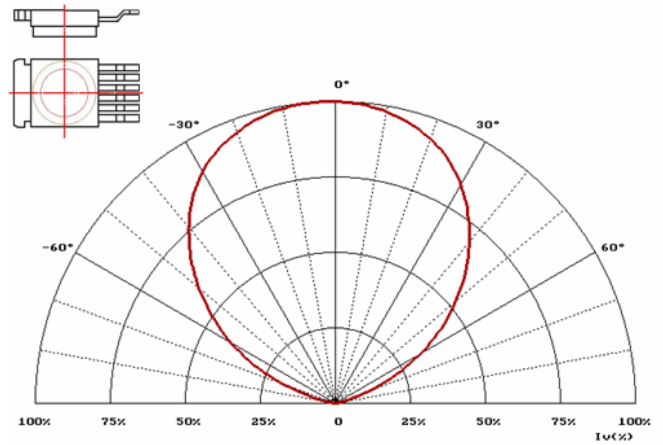
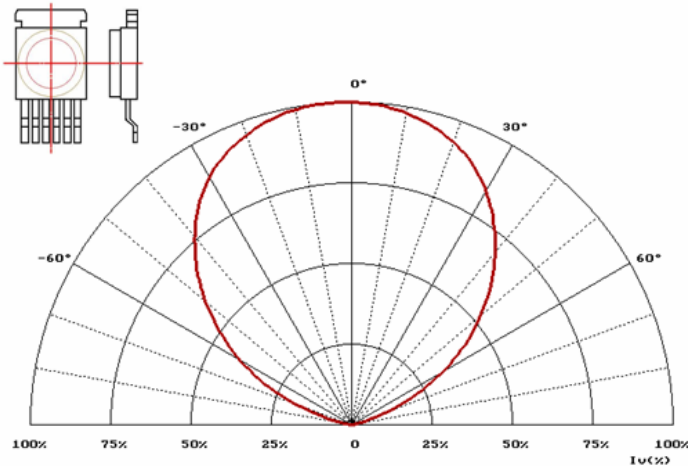

Official Product	HT Part No. HT-P318FCHU-ZZZZ	Your Part No.		Data Sheet No.
Tentative Product	*****	*****		HT-P318FCHU-ZZZZ
Specifications are subject to changes for improvement without advance notice. Proprietary data, drawings, and company confidential all rights reserved.		March. 01, 2007	Version of 1.0	Page 10/19

Characteristics Curves (Red)

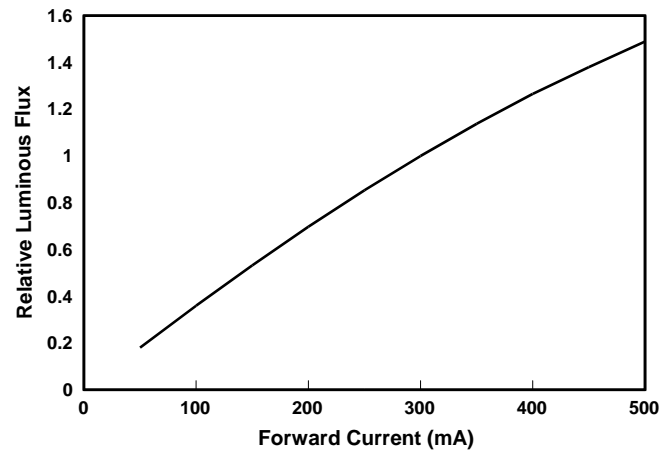
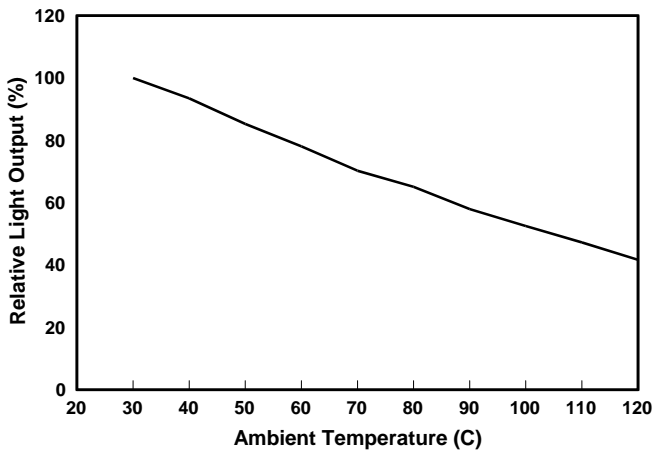
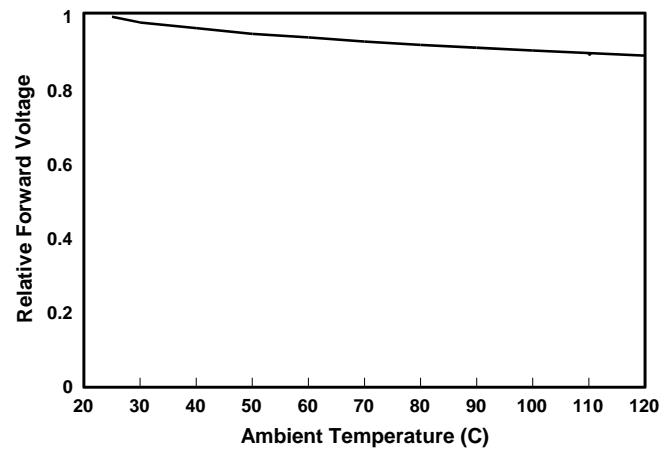
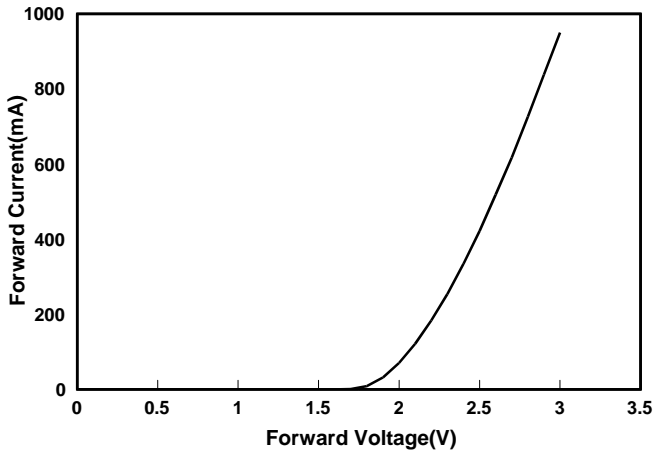
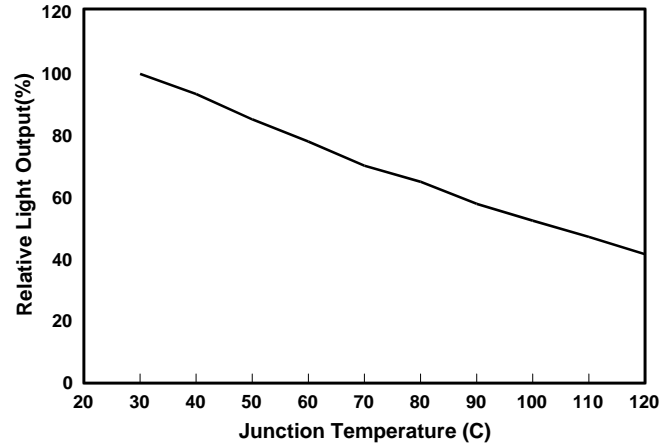
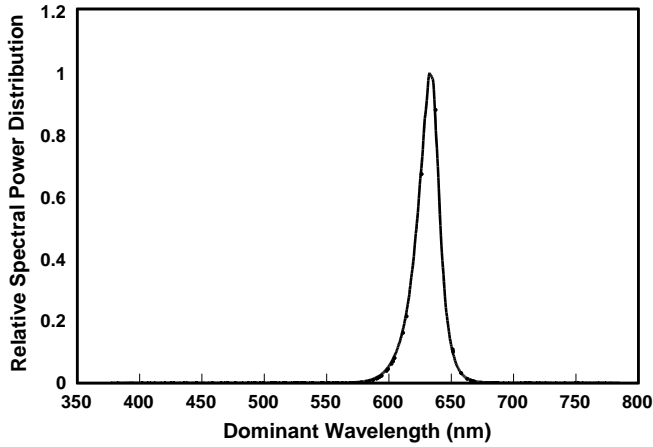

Official Product	HT Part No. HT-P318FCHU-ZZZZ	Your Part No.	Data Sheet No.
Tentative Product	*****	*****	HT-P318FCHU-ZZZZ
Specifications are subject to changes for improvement without advance notice. Proprietary data, drawings, and company confidential all rights reserved.	March. 01, 2007	Version of 1.0	Page 11/19

Characteristics Curves (Green)

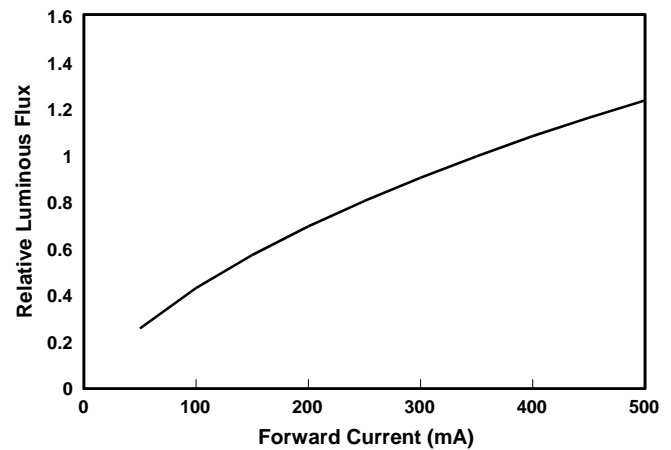
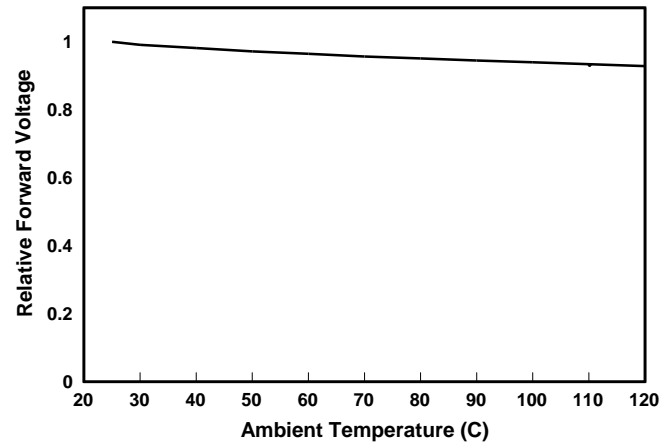
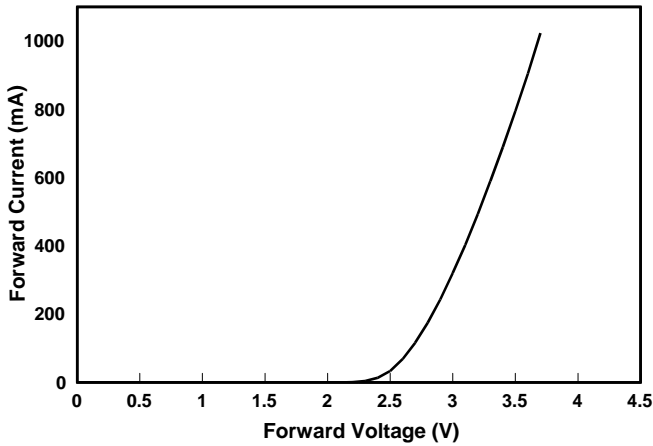
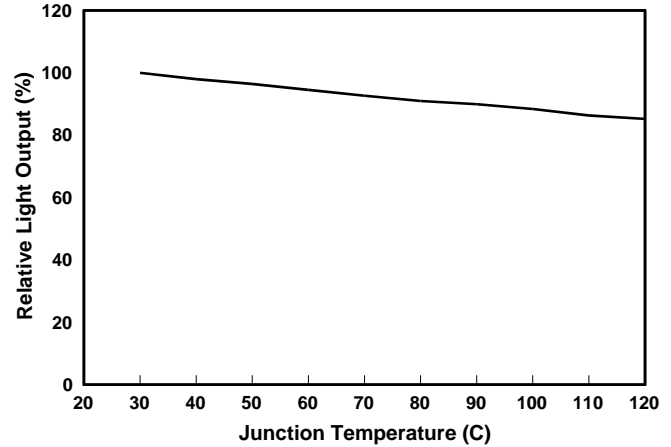
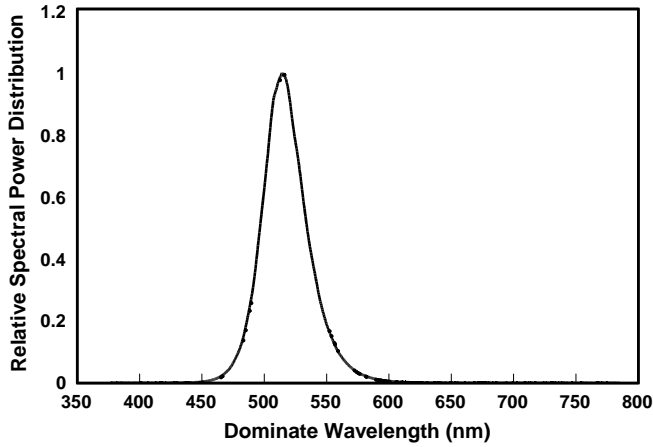

Official Product	HT Part No. HT-P318FCHU-ZZZZ	Your Part No.		Data Sheet No.
Tentative Product	*****	*****		HT-P318FCHU-ZZZZ
Specifications are subject to changes for improvement without advance notice. Proprietary data, drawings, and company confidential all rights reserved.		March. 01, 2007	Version of 1.0	Page 12/19

Characteristics Curves (Blue)

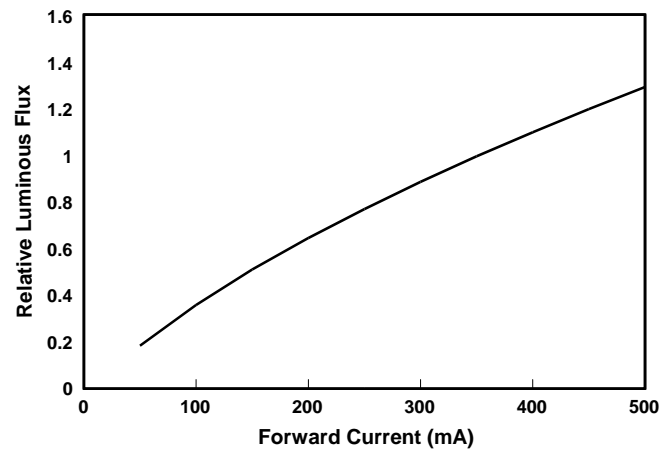
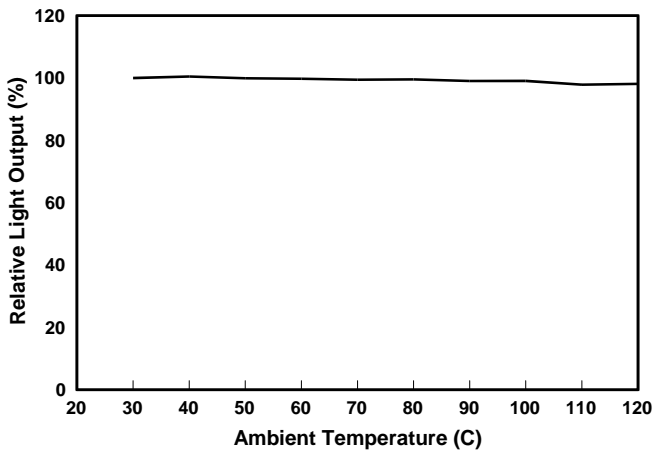
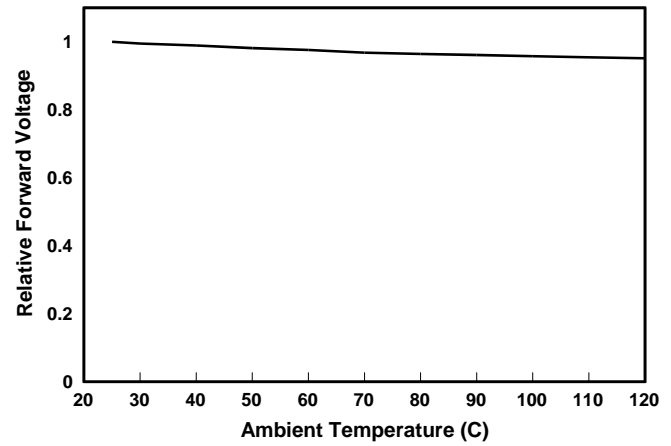
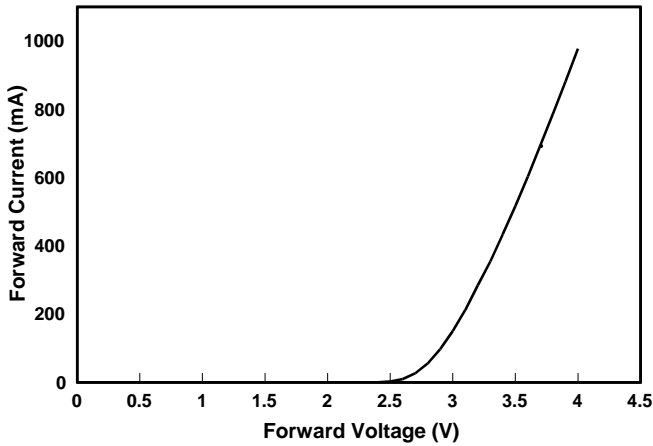
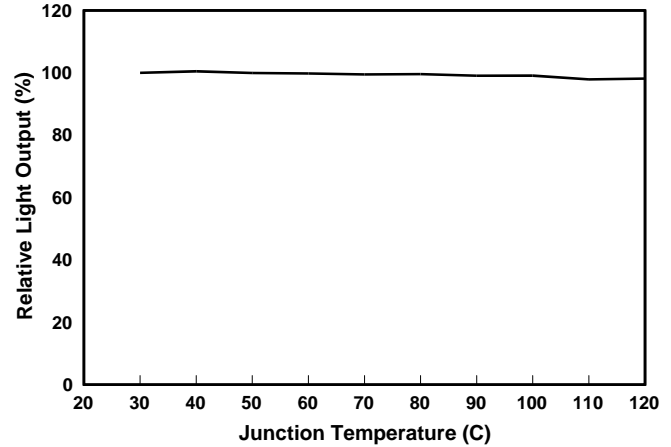
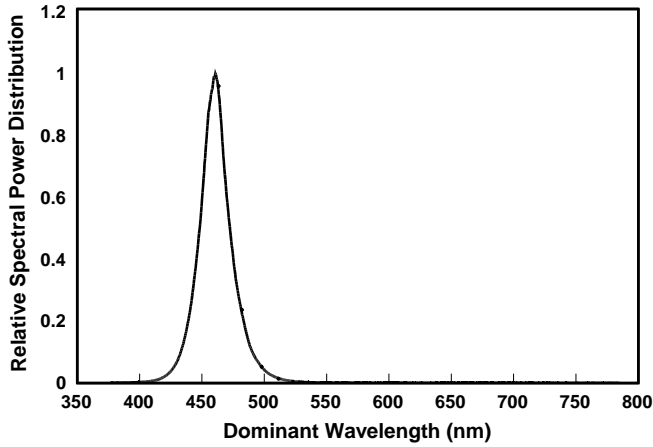

Official Product	HT Part No. HT-P318FCHU-ZZZZ	Your Part No.	Data Sheet No.
Tentative Product	*****	*****	HT-P318FCHU-ZZZZ
Specifications are subject to changes for improvement without advance notice. Proprietary data, drawings, and company confidential all rights reserved.	March. 01, 2007	Version of 1.0	Page 13/19

Tube and Packing

Tube Dimension

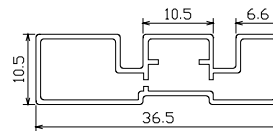
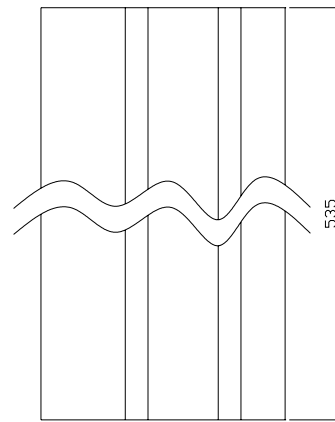
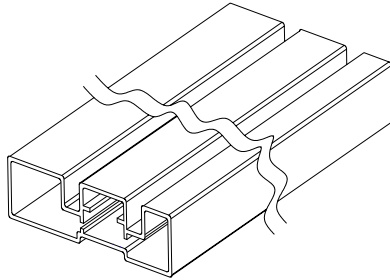

Packing Model

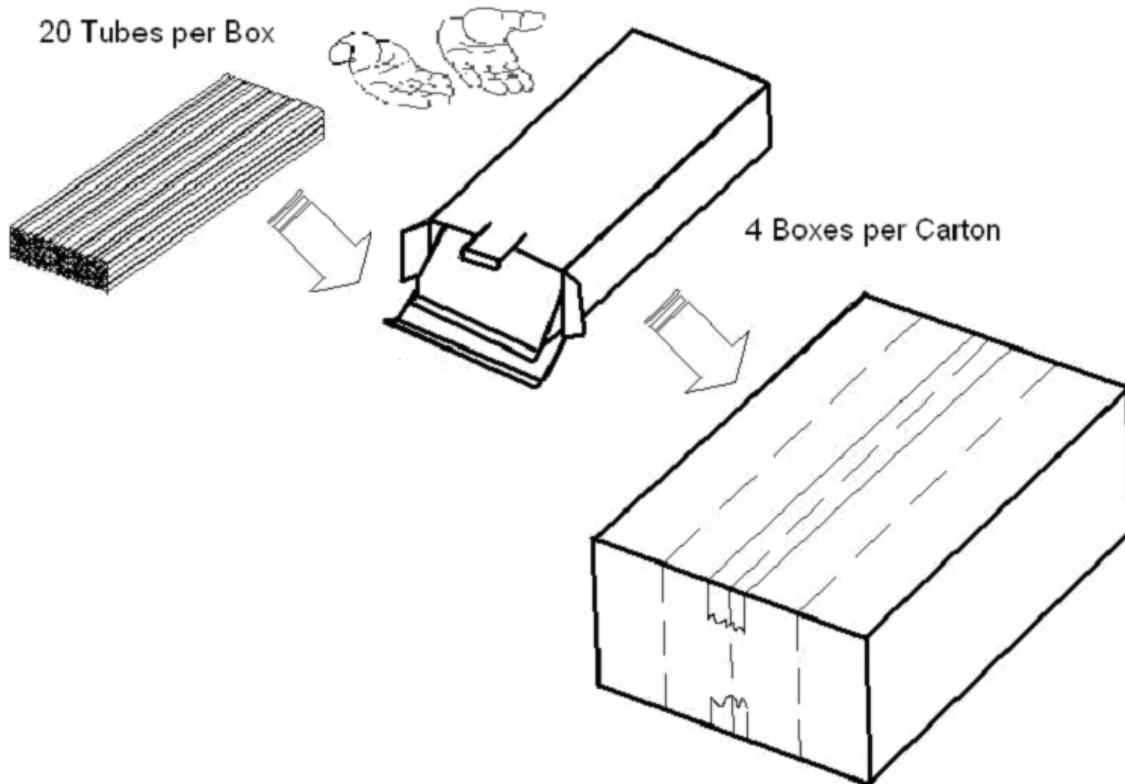

Official Product	HT Part No. HT-P318FCHU-ZZZZ	Your Part No.		Data Sheet No.
Tentative Product	*****	*****		HT-P318FCHU-ZZZZ
Specifications are subject to changes for improvement without advance notice. Proprietary data, drawings, and company confidential all rights reserved.		March. 01, 2007	Version of 1.0	Page 14/19

Precautions

1. Avoid exposure to moisture at all times during transportation or storage.
2. Anti-Static precaution must be taken when handling GaN, InGaN, and AlInGaP products.
3. It is suggested to connect the unit with a current limiting resistor of the proper size. Avoid applying a reverse voltage beyond the specified limit.
4. Avoid operation beyond the limits as specified by the absolute maximum ratings.
5. Avoid direct contact with the surface through which the LED emits light.
6. If possible, assemble the unit in a clean room or dust-free environment.

Official Product	HT Part No. HT-P318FCHU-ZZZZ	Your Part No.		Data Sheet No.
Tentative Product	*****	*****		HT-P318FCHU-ZZZZ
Specifications are subject to changes for improvement without advance notice. Proprietary data, drawings, and company confidential all rights reserved.		March. 01, 2007	Version of 1.0	Page 15/19

Reflow Soldering

- Recommended tin glue specifications: melting temperature in the range of 178~192 °C
- The recommended reflow soldering profile is as follows (temperatures indicated are as measured on the surface of the LED resin):

Lead Solder Profile

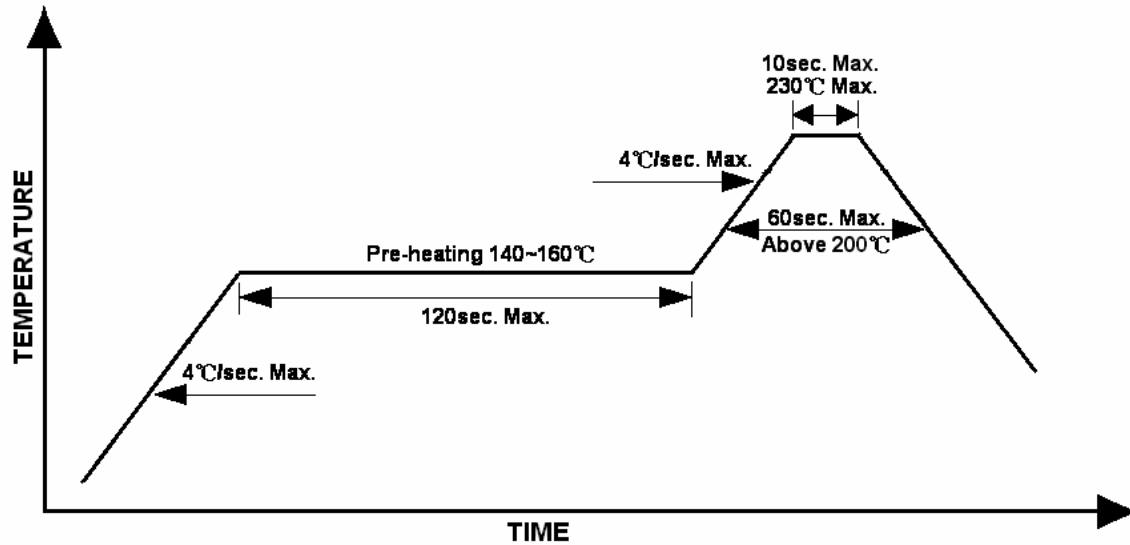

Lead-free Solder Profile

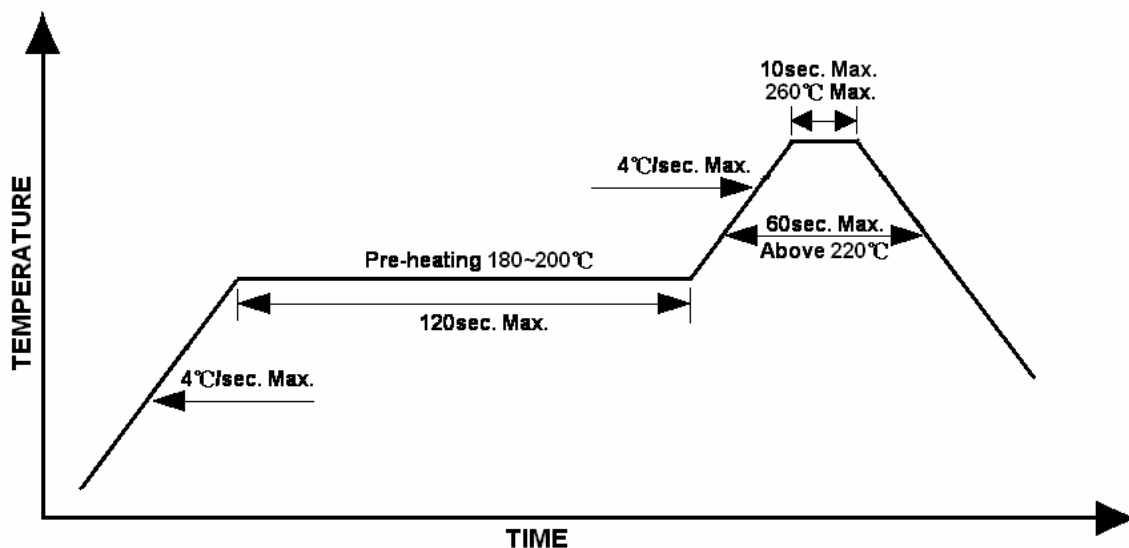

Official Product	HT Part No. HT-P318FCHU-ZZZZ	Your Part No.		Data Sheet No.
Tentative Product	*****	*****		HT-P318FCHU-ZZZZ
Specifications are subject to changes for improvement without advance notice. Proprietary data, drawings, and company confidential all rights reserved.		March. 01, 2007	Version of 1.0	Page 16/19

Reworking

- Rework should be completed within 5 seconds under 260 °C.
- Manual soldering (not recommended):
Soldering tin material: tin 6/4 alloy or contained Ag.
To prevent cracking, bake before manual soldering.
Temperature of iron tip: 300 °C±5 °C maximum (25W)
Soldering duration: 3sec±1sec

Cleaning

Following are cleaning procedures after soldering:

- An alcohol-based solvent such as isopropyl alcohol (IPA) is recommended.
- Temperature x Time should be 50°C x 30sec. or <30°C x 3min
- Ultra sonic cleaning: < 15W/ bath; bath volume ≤ 1liter
- Curing: 100 °C max, <3min

Cautions of Pick and Place

- Avoid stress on the resin at elevated temperature.
- Avoid rubbing or scraping the resin by any object.
- Electric-static may cause damage to the component. Please ensure that the equipment is properly grounded. Use of an ionizer fan is recommended.

Storage

- It is recommended that products be stored under the following conditions:
Humidity: 60%R.H. maximum
Temperature: 5°C ~ 30°C (41°F ~ 86°F)
- Shelf life in sealed bag: 6 months at <40°C and <90%R.H.
- After opening the bag, devices that will be subjected to soldering or equivalent processing should be used within one year at a condition of ≤30°C / 60%R.H.

Official Product	HT Part No. HT-P318FCHU-ZZZZ	Your Part No.		Data Sheet No.
Tentative Product	*****	*****		HT-P318FCHU-ZZZZ
Specifications are subject to changes for improvement without advance notice. Proprietary data, drawings, and company confidential all rights reserved.		March. 01, 2007	Version of 1.0	Page 17/19

Reliability Test

Item	Duration	Standards Reference		Conditions	Criteria
		MIL-STD 883 Ref	JIS C 7021 Ref		
High Temperature Operating Life (HTOL)	1000 Hours			55°C, I _F =max DC (Note 1)	Note 2
Room Temperature Operating Life (RTOL)	1000 Hours			25°C, I _F =max DC (Note 1)	Note 2
Low Temperature Operating Life (LTOL)	1000 Hours			-40°C, I _F =max DC	Note 2
Wet High Temperature Operating Life (WHTOL)	1000 Hours		Method B-11, Condition C	85°C/85%RH, I _F =max DC	Note 2
Powered Temperature Cycle (PTMCL)	200 Cycles			-40°C/85°C, 18min dwell, 42min xfer (2 hours cycle), 5min ON/ 5min OFF, I _F =max DC	Note 2
Non Operating Temperature Cycle (TMCL)	200 Cycles	1010	Method A-4	-40°C/120°C, 30min dwell/ 5 min xfer	No Catastrophic
High Temperature Storage Life (HTSL)	1000 Hours	1005	Method B-10	110°C, non operating	Note 2
Low Temperature Storage Life (LTSL)	1000 Hours	1005	Method B-12	-40°C, non operating	Note 2
Non Operating Thermal Shock (TMSK)	200 Cycles			-40°C/110°C, 20min dwell/<20 sec xfer	No Catastrophic
Non Operating Thermal Shock (TMSK)	200 Cycles			-40°C/120°C, 20min dwell/<20 sec xfer	No Catastrophic
Mechanical Shock	5 Shocks	2002	Method A-7 Condition F	1500G, 0.5 sec pulse, 5shocks each 6 axis	No Catastrophic
Natural Drop	3X		Method A-8	On concrete from 1.2m	No Catastrophic
Variable Vibration Frequency		2007	Method A-10 Condition D	10-2000-10 Hz, log or linear sweep rate 20G about 1min, 1.5mm, 3X/axis	No Catastrophic
Variable Vibration Frequency		2007	Method A-10 Condition D	10-55-10 Hz, ±0.75mm, 55-2000, 10G, 1 octave/min, 3X/axis	No Catastrophic
Random Vibration				6G RMS from 10 to 2KHz, 10min/axis	No Catastrophic
Solder Heat Resistance (SHR)				260°C±5°C, 10 sec	No Catastrophic
Solder ability				Steam age for 16hr, then solder dip at 245°C for 5sec	Solder Coverage
Lead Strength				1 lb, 30sec	No Catastrophic
Lead Fatigue				1 lb, 3X45° bend	No Catastrophic
Salt Atmosphere	48 Hours	1009		35°C	No Catastrophic

Note 1: Dependent upon the maximum de-rating curve

Note 2: Failure criteria includes units with catastrophic failure, or units with greater than 50% I_v degradation at 1000 hours, or an average I_v degradation for the test of greater than 35% at 1000 hours

Official Product	HT Part No. HT-P318FCHU-ZZZZ	Your Part No.		Data Sheet No.
Tentative Product	*****	*****		HT-P318FCHU-ZZZZ
Specifications are subject to changes for improvement without advance notice. Proprietary data, drawings, and company confidential all rights reserved.		March. 01, 2007	Version of 1.0	Page 18/19

Revision History

Changes since last revision	Page	Version No.	Revision Date
New format		1.0	03-01-2007

Official Product	HT Part No. HT-P318FCHU-ZZZZ	Your Part No.	Data Sheet No.
Tentative Product	*****	*****	HT-P318FCHU-ZZZZ
Specifications are subject to changes for improvement without advance notice. Proprietary data, drawings, and company confidential all rights reserved.	March. 01, 2007	Version of 1.0	Page 19/19