

Cree® XLamp® MC-E LED

Binning and Labeling

Introduction

This document describes the product nomenclature required to select and order Cree XLamp MC-E LEDs. XLamp MC-E LEDs are tested and sorted into bins which are then combined into orderable kits identified by an order code.

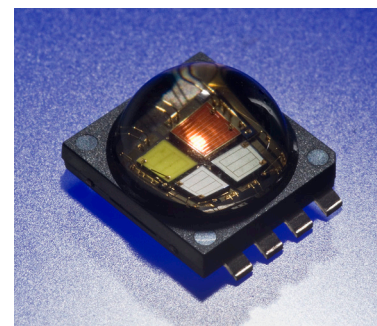

All XLamp LEDs are tested and sorted by color and brightness into a unique bin. Each bin contains LEDs from only one color and brightness group and is uniquely identified by a bin code. White XLamp LEDs are sorted by chromaticity (color) and luminous flux (brightness). Color XLamp LEDs are sorted by dominant wavelength (color) and luminous flux (brightness). LEDs are shipped on reels containing LEDs from one bin and are always labeled with the appropriate bin code.

Kits contain LEDs from a number of similar bins and are fully defined by their order codes. A full explanation of the order codes for XLamp MC-E, as well as a list of standard order codes, is provided in this document.

Table of Contents

Bin and Order-Code Format (White)	2
Bin and Order-Code Format (EasyWhite™)	3
Bin and Order-Code Format (Color)	4
Performance Groups – Brightness	5
Performance Groups – Chromaticity	6
Cree’s Standard Chromaticity Regions Plotted on the 1931 CIE Curve	8
Standard Order Codes and Bins (MC-E Cool White)	10
Standard Order Codes and Bins (MC-E Neutral White)	10
Standard Order Codes and Bins (MC-E Warm White)	11
Standard Order Codes and Bins (MC-E EasyWhite™)	11
Standard Order Codes and Bins (MC-E Color)	12



Bin and Order-Code Format (White)

Bin codes and order codes are configured in the following manner:

Order Code

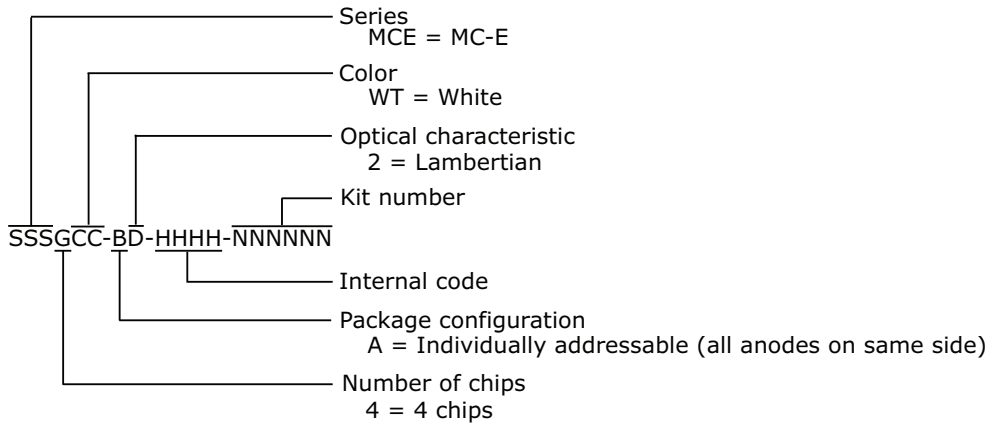

Bin Code

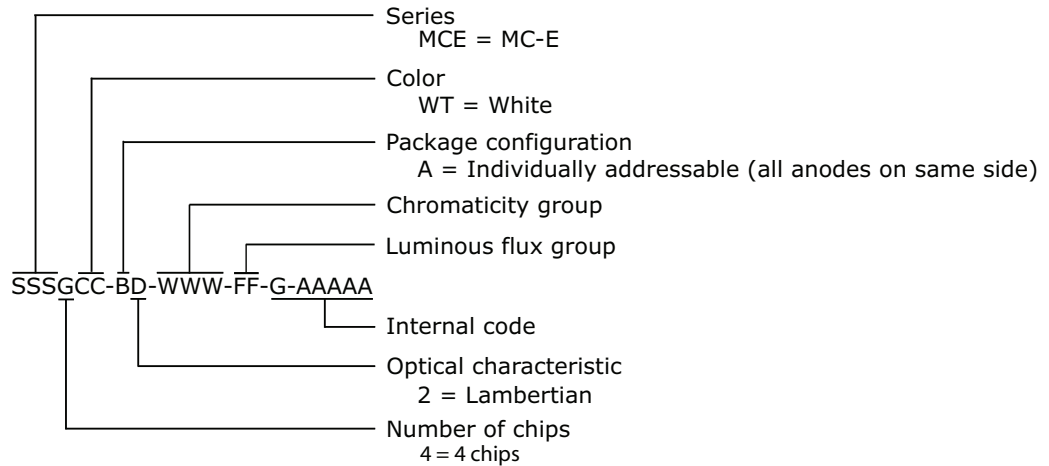



Bin and Order-Code Format (EasyWhite™)

Bin codes and order codes are configured in the following manner:

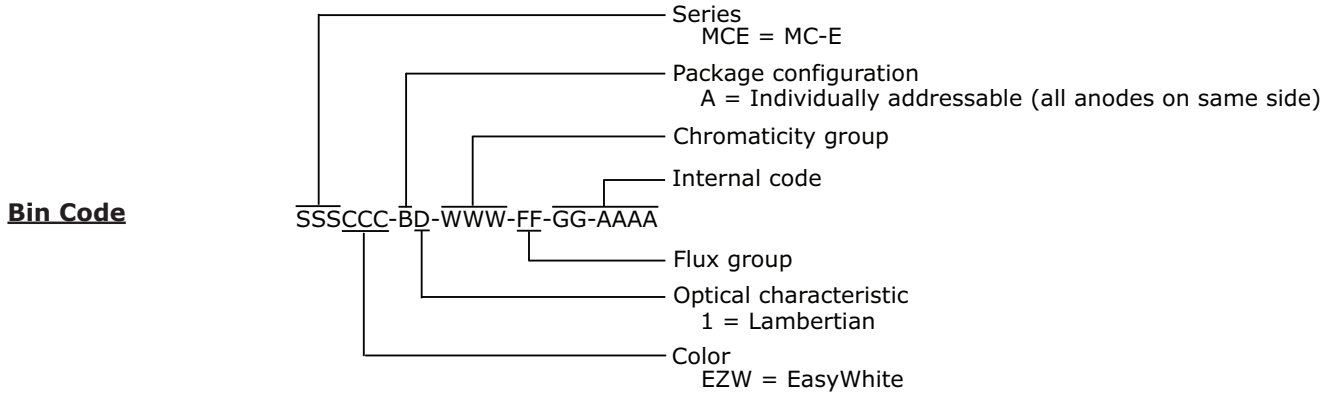
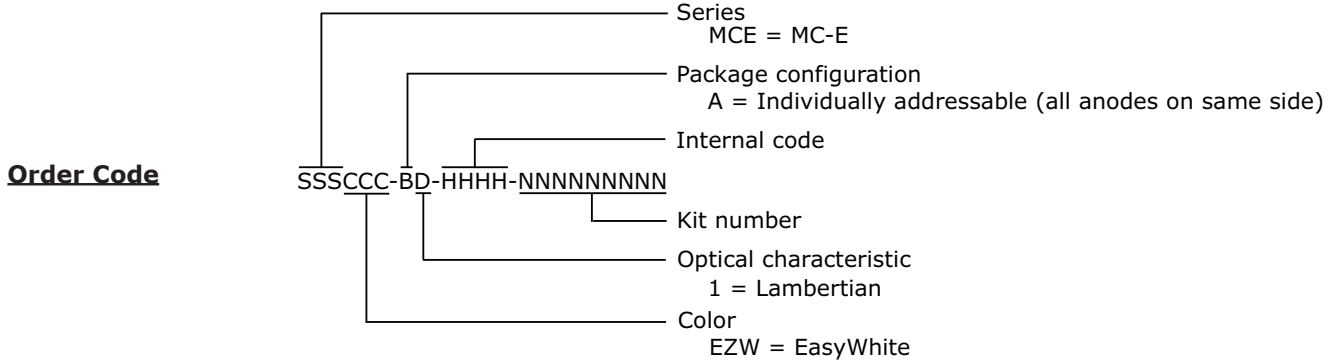



Bin and Order-Code Format (Color)

Bin codes and order codes are configured in the following manner:

Order Code

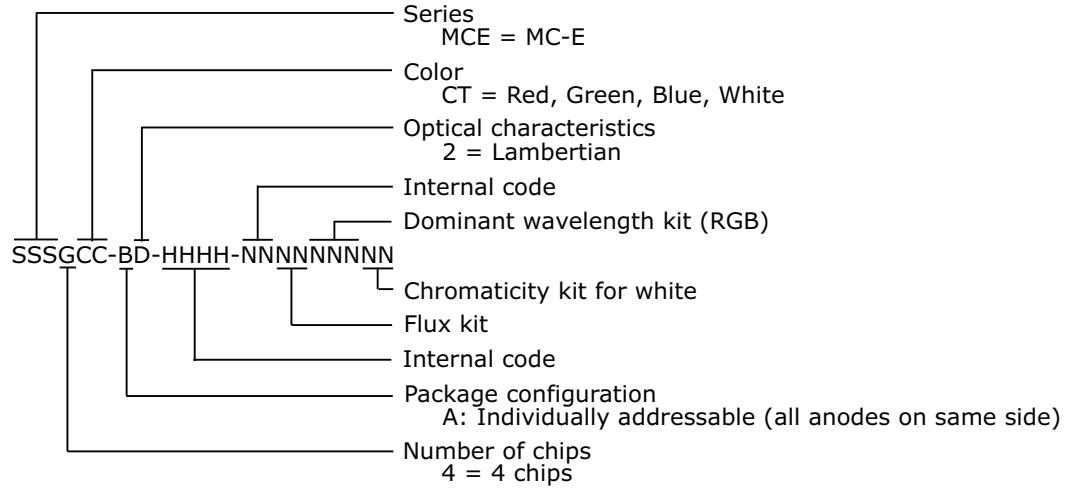

Bin Code

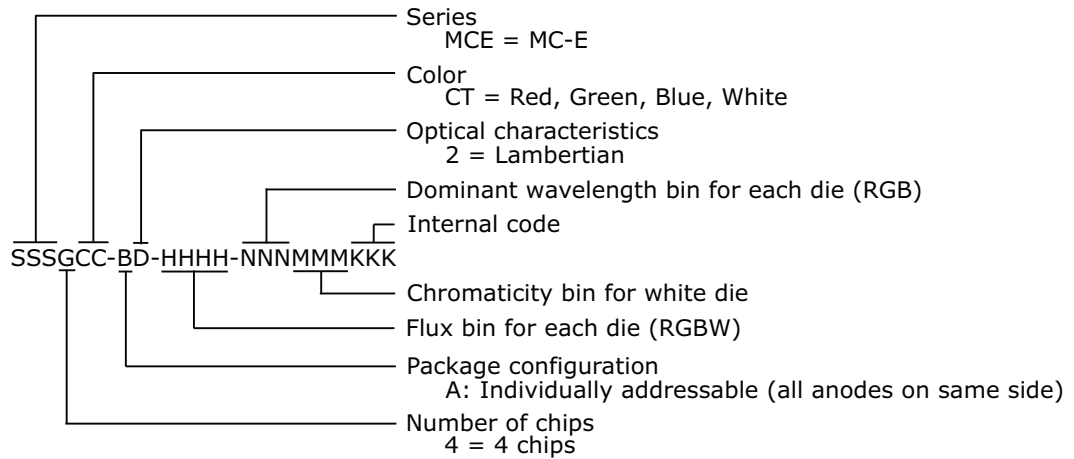



Performance Groups – Brightness

XLamp MC-E White LEDs are tested for luminous flux and placed into one of the following luminous-flux groups:

Group Code	Min. Luminous Flux @ 350 mA (lm)	Max. Luminous Flux @ 350 mA (lm)
F	210	240
G	240	280
H	280	320
J	320	370
K	370	430
M	430	490

- * Flux and chromaticity are measured with each LED die connected to independent drive circuits at 350 mA.
- * The flux and chromaticity are measured with all LEDs lit simultaneously.

Each LED die in the XLamp MC-E Color LED is tested individually for luminous flux and placed into one of the following luminous-flux groups. The luminous-flux groups for the XLamp MC-E Color LED specify only minimum flux and do not have a maximum.

Color	Group Code	Min. Luminous Flux @ 350 mA
Red	K	30.6
Green	P	67.2
Blue	E	8.2
White	J	80
	K	100



Performance Groups – Chromaticity

XLamp MC-E White LEDs and the white LED in the XLamp MC-E Color LED are tested for chromaticity and placed into one of the regions defined by the bounding coordinates on the following pages. The XLamp MC-E White LED is tested with each LED die connected to independent drive circuits at 350 mA and all LEDs lit simultaneously. The white LED in the XLamp MC-E Color LED is tested individually.

Region	x	y	Region	x	y
WK	.283	.284	WF	.314	.355
	.295	.297		.316	.332
	.298	.288		.306	.322
	.287	.276		.301	.342
WA	.292	.306	WP	.317	.319
	.295	.297		.329	.330
	.283	.284		.329	.318
	.279	.291		.318	.308
WM	.295	.297	WD	.329	.345
	.308	.311		.329	.330
	.310	.300		.317	.319
	.298	.288		.316	.332
WB	.306	.322	WG	.329	.369
	.308	.311		.329	.345
	.295	.297		.316	.332
	.292	.306		.314	.355
WE	.301	.342	WJ	.329	.330
	.306	.322		.329	.345
	.292	.306		.346	.359
	.287	.321		.344	.342
WN	.308	.311	WH	.348	.384
	.317	.319		.346	.359
	.318	.308		.329	.345
	.310	.300		.329	.369
WC	.316	.332			
	.317	.319			
	.308	.311			
	.306	.322			



Performance Groups – Chromaticity (continued)

Region	x	y	Region	x	y	Region	x	y	Region	x	y		
3A	.3371	.3490	3B	.3376	.3616	3C	.3463	.3687	3D	.3451	.3554		
	.3451	.3554		.3463	.3687		.3551	.3760		.3533	.3620		
	.3440	.3428		.3451	.3554		.3533	.3620		.3451	.3554	.3440	.3428
	.3366	.3369		.3371	.3490		.3451	.3554		.3440	.3428		
4A	.3512	.3465	4B	.3529	.3597	4C	.3615	.3659	4D	.3590	.3521		
	.3529	.3597		.3548	.3736		.3641	.3804		.3615	.3659		
	.3615	.3659		.3641	.3804		.3736	.3874		.3702	.3722		
	.3590	.3521		.3615	.3659		.3702	.3722		.3670	.3578		
5A	.3670	.3578	5B	.3702	.3722	5C	.3825	.3798	5D	.3783	.3646		
	.3702	.3722		.3736	.3874		.3869	.3958		.3825	.3798		
	.3825	.3798		.3869	.3958		.4006	.4044		.3950	.3875		
	.3783	.3646		.3825	.3798		.3950	.3875		.3898	.3716		
6A	.3889	.3690	6B	.3941	.3848	6C	.4080	.3916	6D	.4017	.3751		
	.3941	.3848		.3996	.4015		.4146	.4089		.4080	.3916		
	.4080	.3916		.4146	.4089		.4299	.4165		.4221	.3984		
	.4017	.3751		.4080	.3916		.4221	.3984		.4147	.3814		
7A	.4147	.3814	7B	.4221	.3984	7C	.4342	.4028	7D	.4259	.3853		
	.4221	.3984		.4299	.4165		.4430	.4212		.4342	.4028		
	.4342	.4028		.4430	.4212		.4562	.4260		.4465	.4071		
	.4259	.3853		.4342	.4028		.4465	.4071		.4373	.3893		
8A	.4373	.3893	8B	.4465	.4071	8C	.4582	.4099	8D	.4483	.3919		
	.4465	.4071		.4562	.4260		.4687	.4289		.4582	.4099		
	.4582	.4099		.4687	.4289		.4813	.4319		.4700	.4126		
	.4483	.3919		.4582	.4099		.4700	.4126		.4593	.3944		
35F	.3981	.3800	30F	.4242	.3919	27F	.4475	.3994					
	.4040	.3966		.4322	.4096		.4573	.4178					
	.4186	.4037		.4449	.4141		.4695	.4207					
	.4116	.3865		.4359	.3960		.4589	.4021					

Performance Groups – Dominant Wavelength

The red, green and blue LEDs in the XLamp MC-E Color LED are tested individually for dominant wavelength (DWL) and sorted into one of the DWL bins defined below.

Color	DWL Group	Min. DWL @ 350 mA	Max. DWL @ 350 mA
Blue	K	450	455
	L	455	460
	M	460	465
Green	2	520	525
	3	525	530
	4	530	535
Red	A	620	630

This document is provided for informational purposes only and is not a warranty or a specification. For product specifications, please see the data sheets available at www.cree.com. For warranty information, please contact Cree Sales at sales@cree.com.

Copyright © 2008-2010 Cree, Inc. All rights reserved. The information in this document is subject to change without notice. Cree, the Cree logo, and XLamp are registered trademarks and EasyWhite is a trademark of Cree, Inc.

Cree, Inc.
4600 Silicon Drive
Durham, NC 27703
USA Tel: +1.919.313.5300
www.cree.com/xlamp



Cree's Standard Chromaticity Regions Plotted on the 1931 CIE Curve

Cool White

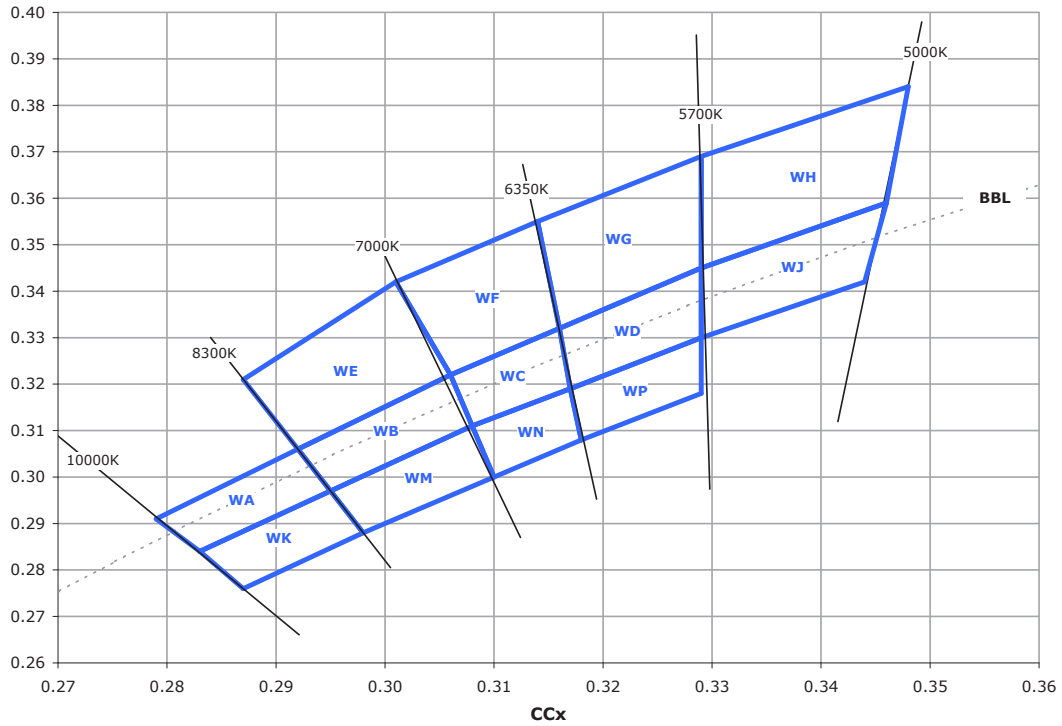

Neutral and Warm White

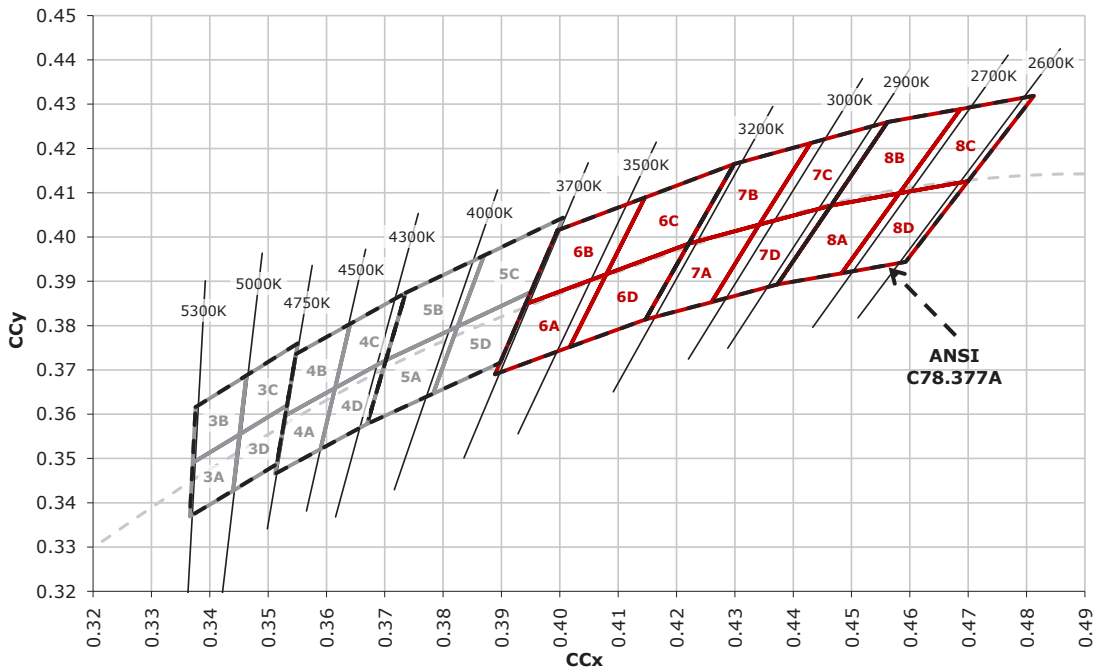

This document is provided for informational purposes only and is not a warranty or a specification. For product specifications, please see the data sheets available at www.cree.com. For warranty information, please contact Cree Sales at sales@cree.com.

Copyright © 2008-2010 Cree, Inc. All rights reserved. The information in this document is subject to change without notice. Cree, the Cree logo, and XLamp are registered trademarks and EasyWhite is a trademark of Cree, Inc.

Cree, Inc.
4600 Silicon Drive
Durham, NC 27703
USA Tel: +1.919.313.5300
www.cree.com/xlamp



Cree's Standard Chromaticity Regions Plotted on the 1931 CIE Curve (continued)

EasyWhite

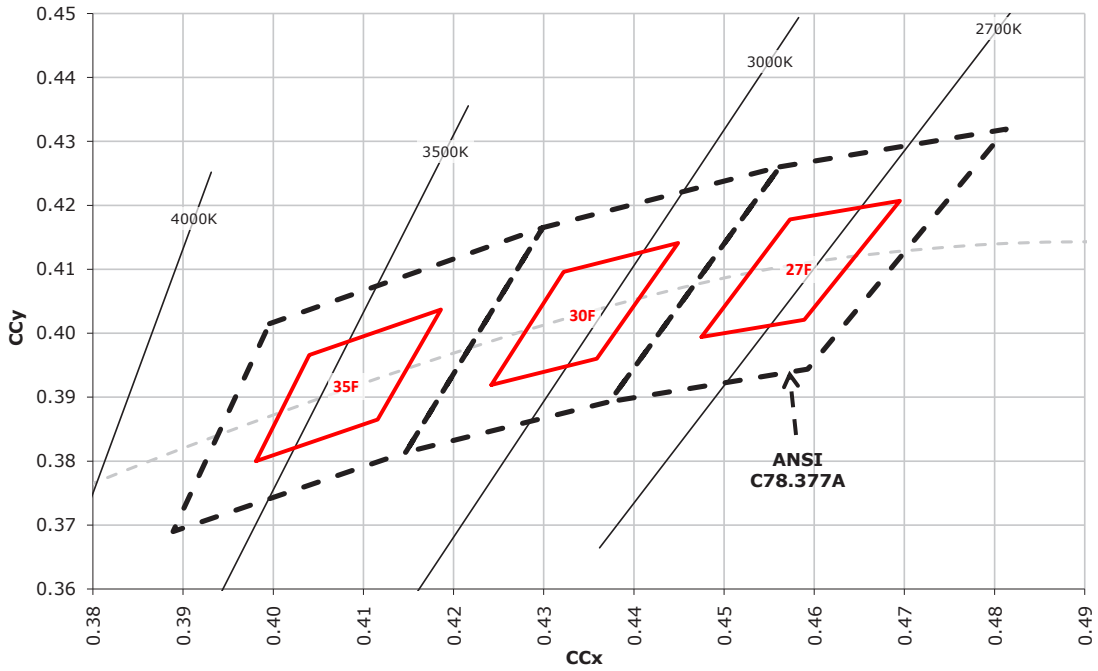

This document is provided for informational purposes only and is not a warranty or a specification. For product specifications, please see the data sheets available at www.cree.com. For warranty information, please contact Cree Sales at sales@cree.com.

Copyright © 2008-2010 Cree, Inc. All rights reserved. The information in this document is subject to change without notice. Cree, the Cree logo, and XLamp are registered trademarks and EasyWhite is a trademark of Cree, Inc.

Cree, Inc.
4600 Silicon Drive
Durham, NC 27703
USA Tel: +1.919.313.5300
www.cree.com/xlamp



Standard Order Codes and Bins (MC-E Cool White)

The following tables list standard kit numbers and performance bins. Kit numbers completely describe an order code's chromaticity regions and luminous flux range.

XLamp MC-E LED Standard Order Codes - White			
Min. Luminous Flux (lm) @ 350 mA*		Chromaticity Regions	Kit Number
Group	Flux (lm)		
Cool White (5000 K - 10,000 K)			
K	370	WA, WB, WC, WD, WE, WF, WG, WH, WJ, WK, WM, WN, WP	000K01
		WC, WD, WF, WG	000K02
		WC, WD, WF, WG, WH, WJ, WN, WP	000K03
M	430	WA, WB, WC, WD, WE, WF, WG, WH, WJ, WK, WM, WN, WP	000M01
		WC, WD, WF, WG	000M02
		WC, WD, WF, WG, WH, WJ, WN, WP	000M03

For other flux and chromaticity combinations, contact Cree or an authorized distributor.

* Cree XLamp MC-E order codes specify only a minimum flux bin and not a maximum. Cree may ship reels in flux bins higher than the minimum specified by the order code without advance notice. Shipments will always adhere to the chromaticity or DWL bin restrictions specified by the order code.

Standard Order Codes and Bins (MC-E Neutral White)

The following tables list standard kit numbers and performance bins. Kit numbers completely describe an order code's chromaticity regions and luminous flux range.

XLamp MC-E LED Standard Order Codes - White				
Minimum Luminous Flux (lm) @ 350 mA*		Chromaticity Regions	Kit Number	CCT
Group	Flux (lm)			
Neutral White (3700 K - 5000 K)				
H	280	5C, 5D, 6A, 6B	000HF6	3700 K
J	320	3A, 3B, 3C, 3D	000JE3	5000 K
		3C, 3D, 4A, 4B	000JF4	4750 K
		4A, 4B, 4C, 4D	000JE4	4500 K
		4C, 4D, 5A, 5B	000JF5	4300 K
		5A, 5B, 5C, 5D	000JE5	4000 K
		5C, 5D, 6A, 6B	000JF6	3700 K
K	370	3A, 3B, 3C, 3D	000KE3	5000 K
		3C, 3D, 4A, 4B	000KF4	4750 K
		4A, 4B, 4C, 4D	000KE4	4500 K
		4C, 4D, 5A, 5B	000KF5	4300 K
		5A, 5B, 5C, 5D	000KE5	4000 K

For other flux and chromaticity combinations, contact Cree or an authorized distributor.

* Cree XLamp MC-E order codes specify only a minimum flux bin and not a maximum. Cree may ship reels in flux bins higher than the minimum specified by the order code without advance notice. Shipments will always adhere to the chromaticity or DWL bin restrictions specified by the order code.



Standard Order Codes and Bins (MC-E Warm White)

The following tables list standard kit numbers and performance bins. Kit numbers completely describe an order code's chromaticity regions and luminous flux range.

XLamp MC-E LED Standard Order Codes - White				
Minimum Luminous Flux (lm) @ 350 mA*		Chromaticity Regions	Kit Number	CCT
Group	Flux (lm)			
Warm White (2600 K - 3700 K)				
G	240	6C, 6D, 7A, 7B	000GF7	3200 K
		7A, 7B, 7C, 7D	000GE7	3000 K
		7C, 7D, 8A, 8B	000GF8	2900 K
		8A, 8B, 8C, 8D	000GE8	2700 K
H	280	6A, 6B, 6C, 6D	000HE6	3500 K
		6C, 6D, 7A, 7B	000HF7	3200 K
		7A, 7B, 7C, 7D	000HE7	3000 K
		7C, 7D, 8A, 8B	000HF8	2900 K
J	320	8A, 8B, 8C, 8D	000HE8	2700 K
		6A, 6B, 6C, 6D	000JE6	3500 K
		6C, 6D, 7A, 7B	000JF7	3200 K
		7A, 7B, 7C, 7D	000JE7	3000 K
		7C, 7D, 8A, 8B	000JF8	2900 K
		8A, 8B, 8C, 8D	000JE8	2700K

For other flux and chromaticity combinations, contact Cree or an authorized distributor.

* Cree XLamp MC-E order codes specify only a minimum flux bin and not a maximum. Cree may ship reels in flux bins higher than the minimum specified by the order code without advance notice. Shipments will always adhere to the chromaticity or DWL bin restrictions specified by the order code.

Standard Order Codes and Bins (MC-E EasyWhite™)

The following tables list standard kit numbers and performance bins. Kit numbers completely describe an order code's chromaticity regions and luminous flux range.

XLamp MC-E LED Standard Order Codes - EasyWhite				
Minimum Luminous Flux (lm) @ 350 mA*		Chromaticity Regions	Kit Number	CCT
Group	Flux (lm)			
EasyWhite				
H	280	35F	0000H035F	3500 K
		30F	0000H030F	3000 K
		27F	0000H027F	2700 K
J	320	35F	0000J035F	3500 K
		30F	0000J030F	3000 K
		27F	0000J027F	2700 K



Standard Order Codes and Bins (MC-E Color)

The following tables list standard kit numbers and performance bins. Kit numbers completely describe an order code's color or chromaticity bins and luminous flux range.

XLamp MC-E LED Standard Order Codes - Color				
Color	Minimum Luminous Flux (lm) @ 350 mA*		DWL / Chromaticity Bins	Kit Number
	Group	Flux (lm)		
Red	K	30.6	A	00A5AAAA1
Green	P	67.2	2, 3, 4	
Blue	E	8.2	K, L, M	
White	K	100	WC, WD, WF, WG	
Red	K	30.6	A	00A4AAAB1
Green	P	67.2	2, 3, 4	
Blue	E	8.2	K, L, M	
White	J	80	5A, 5B, 5C, 5D	

For other flux and chromaticity combinations, contact Cree or an authorized distributor.

* Cree XLamp MC-E order codes specify only a minimum flux bin and not a maximum. Cree may ship reels in flux bins higher than the minimum specified by the order code without advance notice. Shipments will always adhere to the chromaticity or DWL bin restrictions specified by the order code.

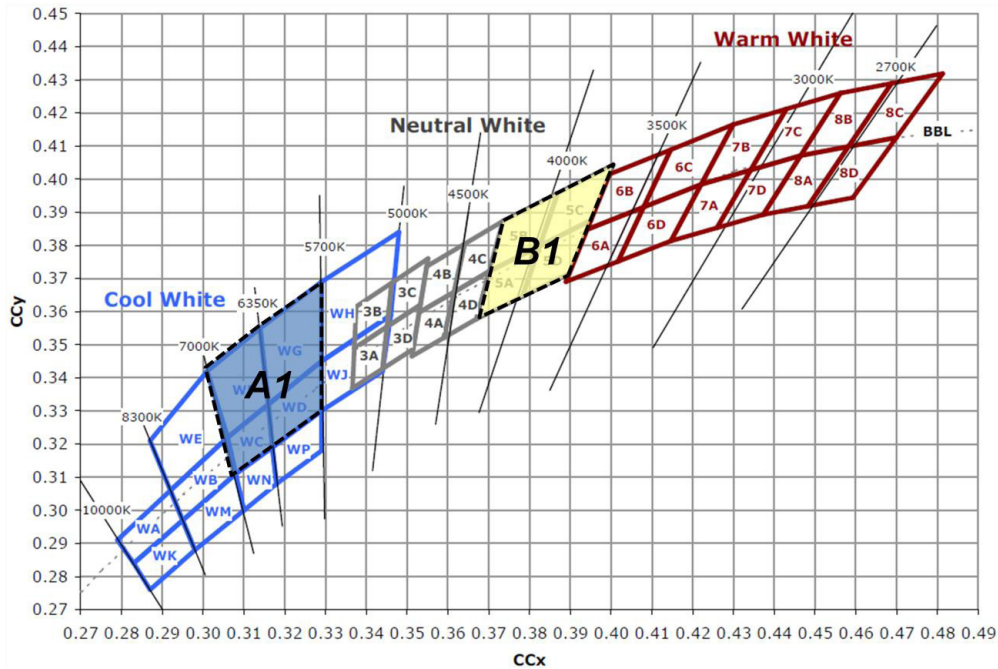

This document is provided for informational purposes only and is not a warranty or a specification. For product specifications, please see the data sheets available at www.cree.com. For warranty information, please contact Cree Sales at sales@cree.com.

Copyright © 2008-2010 Cree, Inc. All rights reserved. The information in this document is subject to change without notice. Cree, the Cree logo, and XLamp are registered trademarks and EasyWhite is a trademark of Cree, Inc.

Cree, Inc.
4600 Silicon Drive
Durham, NC 27703
USA Tel: +1.919.313.5300
www.cree.com/xlamp