

# MSC Q7 Module

## Getting Started Guide

### Contents

<b>Preface .....</b>	<b>2</b>
<b>1 General Information .....</b>	<b>3</b>
1.1 Revisions and Modifications .....	3
1.2 Introduction .....	3
1.3 Additional Components .....	3
1.4 Additional Documentation .....	4
<b>2 Getting started.....</b>	<b>5</b>
2.1 Mechanical Module and Heatspreader mounting .....	5
2.2 Hardware setup.....	6
2.2.1 Jumper Settings .....	6
2.2.2 Display connection – DVI or VGA.....	6
2.2.3 System setup .....	6
2.2.4 Display connection – LCD Panel via LVDS .....	6
2.3 Software Installation.....	8
2.3.1 Windows XP.....	8
2.3.2 Linux .....	9
2.3.3 Windows CE 6.0 .....	9
2.3.4 Windows XPembedded / Windows Embedded Standard .....	9
<b>3 Product Support.....</b>	<b>10</b>

## **Preface**

### **Copyright Notice**

Copyright © 2009 MSC Vertriebs GmbH. All rights reserved.

Copying of this document, providing to others and the use or communication of the contents thereof, are forbidden without express authority from MSC GmbH. Offenders are liable for payment of damages.

All rights are reserved in the event of the grant of a patent or the registration of a utility model or design.

### **Important Information**

This documentation is intended for qualified audiences only. The product described herein is not an end user product. It was developed and manufactured for further processing by trained personnel.

### **Disclaimer**

Although this document has been generated with the utmost care no warranty or liability for correctness or suitability for any particular purpose is implied. The information in this document is provided “as is” and is subject to change without notice.

### **Trademarks**

All used product names, logos or trademarks are property of their respective owners.

# 1 General Information

## 1.1 Revisions and Modifications

Rev.	Date		Comment
1.0	12th May 2009	THEA	Version 1.0
1.1	18th May 2009	THEA	Corrected J0807 setting
1.2	28th June 2009	THEA	Warning for 5V lab supply added
1.3	24 <sup>th</sup> July 2009	THEA	ATX Power Supply issue
1.4	30 <sup>th</sup> Sept 2009	THEA	Jumper infos updated
1.5	26 <sup>th</sup> Oct 2009	THEA	Document renamed + fix screw sizes

## 1.2 Introduction

The Q7 standard is designed for customers who require high performance and low power in a small footprint, for example in mobile applications.

This document is designed as a quick start for customers using the Q7 module for the first time. For the purposes of this user guide it is assumed that the customer has a Q7 module, a heatspreader and a baseboard for the module. Thus in order to get started the following components are required :

- MSC Q7-US15W-00x : MSC Q7 Module
- MSC Q7-HEATSPREADER-US15W-2.7 : Heatspreader for the Q7 module
- MSC Q7-MB-RP : MSC Baseboard for the Q7 module

## 1.3 Additional Components

The following components can be ordered separately from MSC :

- Adaptor cards for displays. Since the Q7 reference platform (Q7-MB-RP) is only provided with a LVDS direct connection to a TFT panel, it may be convenient for use with standard displays to acquire one of the following adaptors.
  - o ADD2 DVI CARD – adaptor for DVI monitor
  - o ADD2 VGA CARD – adaptor for VGA monitor

These adaptor cards can be plugged into the ADD2 slot (X9) on the reference platform baseboard.

The following additional components (not available from MSC) are required to have a fully functional system :

- ATX Power supply
- Display (VGA or DVI-D or LVDS-TFT) with cable
- USB Mouse and Keyboard
- Bootable medium – depends on the Module version, but can be typically :
  - o SATA CDROM or Hard Disk device (not available on MSC Q7-US15W-001)
  - o USB Memory stick
  - o SDIO memory

## 1.4 Additional Documentation

Please also refer to the following documentation :

- The following documentation is available on the MSC Support Website or from your sales / support representative (see section 3).
  - o MSC Q7 User Manual
  - o MSC Q7-MB-RP Users Guide
  - o MSC Q7-MB-RP Schematics
- Q7 Consortium - specification and Baseboard Design guide. Available from :
  - o <http://www.qseven-standard.org/>

## 2 Getting started

### 2.1 Mechanical Module and Heatspreader mounting

- The Q7 module should be first inserted into the Q7 edge connector (X23) on the baseboard.
- The heatspreader is provided with thermal interface material for the Atom CPU and US15W chipset, already mounted. The protective material should be removed from the thermal interface and the heatspreader placed on the module.
- The Q7 module and heatspreader should then be fastened down using the 4 screws provided.

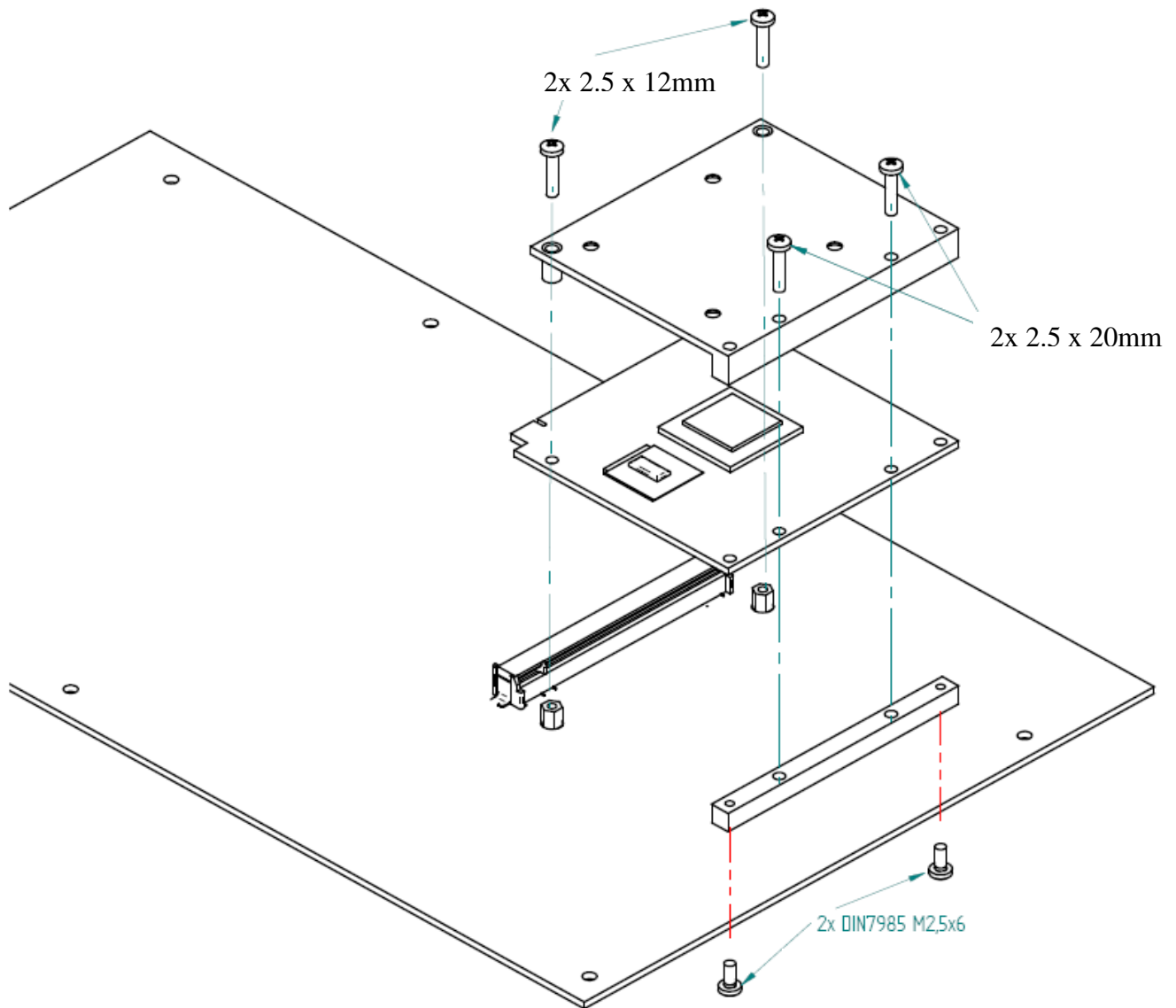

## 2.2 Hardware setup

### 2.2.1 Jumper Settings

- The default jumper settings as described in the MSC Q7-MB-RP Users Guide should be used. Particular attention should be paid to the following jumpers :
  - o Jumper J0701 should be REMOVED (installed only for external BIOS)
  - o Jumper J1602 should be in the 2-3 position, to use SUS\_S5# signal.
  - o Jumper J1601 should be in the 2-3 position for ATX Power Supply.

### 2.2.2 Display connection – DVI or VGA

- The appropriate ADD2 adaptor board (VGA or DVI) must be plugged into the ADD2 card slot (X9) and the display connected to the adaptor card.

### 2.2.3 System setup

- Connect the bootable media to :-
  - o SATA connector (NOT available on MSC Q7-US15W-001) or
  - o USB port or
  - o SDIO port.
- Connect USB mouse and keyboard to USB ports on X3. **NOTE !! – do not use the USB ports on X2 for mouse or keyboard, since these ports only support USB 2.0 devices and not USB 1.1 devices such as USB mouse and USB keyboard.**
- Connect ATX Power supply to the ATX connector (X20). Note : 20 or 24 pin connectors will both work on the board.

**NOTE :** Care should be taken with certain ATX Power Supplies which require a minimum load before switching on. The 12V current draw of the Q7 system may not be sufficient for such power supplies and they will then not switch on. Check with the data sheet of the power supply to see if a minimum load is required.

**NOTE :** for early development it is strongly recommended to use the ATX Power supply. If using the 5V LAB Power supply then be aware that no 12V is provided to the system which has various ramifications such as - display adaptors will not work, TFT displays with 12V backlight power will not work, etc. etc.

- Connect display (either VGA/DVI to adaptor card or TFT via LVDS interface)
- Switch on power supply and press the power button located next to the POST display on the baseboard.
- Press F2 to go into BIOS setup
- Check date and time are correct
- If necessary adjust display settings for your configuration (see User manual) and then save the settings and exit (F10)

### 2.2.4 Display connection – LCD Panel via LVDS

- Many embedded applications use a flat LCD panel which can be connected via the LVDS interface on the Q7-MB-RP (X24 or X25)

- As an example, the NEC NL10276BC16-01 panel is used. This display has following parameters :
  - o 8.4" size, 1024x768 XGA resolution
  - o Single LVDS channel with 18 or 24 bpp colour depth
  - o Uses a CCFL Inverter of type – 84PW021 with 12V backlight power
- The following jumper settings must be set up correctly for the panel :
  - o Panel voltage – J0803 2-3 for 3.3V
  - o Panel enable ctrl signal – J0804 1-2 for high active
  - o Backlight power voltage - J0801 2-3 for 12V
  - o Backlight enable polarity - J0804 1-2 for high active
  - o Source for analog brightness control – J0807 2-3
  - o The LCD EEPROM should be disabled – S0801 all off (high)
- The display is connected to the Q7-MB-RP baseboard as follows :
  - o The JILI Display cable (DRB-KAB-JILI30-TXLD07) is connected between the JILI30 connector on the Q7-MB-RP – X25 and the display.
  - o The backlight inverter (84PW021) must be connected to the display backlight(two flying leads are coming out of the display for this).
  - o The inverter is connected via an inverter power cable to the Q7-MB-RP baseboard connector X26. The following pins of connector X26 must be connected to the backlight inverter :
    - SW\_BLT\_VCC (pin 2) – voltage for backlight inverter
    - LVDS\_BLEN\_BUF (pin 6) – Backlight enable signal
    - LVDS\_BLT\_CTRL\_ANALOG (pin 8) – Backlight brightness level signal
    - GND (pins 9,10)
    - If you need help configuring this cable please contact MSC technical support (see sec. 3)
- BIOS settings
  - o Under BIOS setup -> Advanced -> Video Intel IGD -> IGD LCD Panel Type -> select the panel size matching this panel (1024x768).
  - o It is recommended before enabling the panel in the BIOS (this will only enable the panel for the pre-boot period), to try enabling the Panel under the OS (eg under Windows XP as a clone or extended display) to check the panel operation. To do this under WinXP the graphics properties must be selected (Right click in desktop space) - the GMA500 graphics driver interface is started and the appropriate options (dual display clone or extended Desktop) can be selected.
  - o If the panel is operational under the OS, it can also be enabled during the BIOS start up period using the appropriate BIOS settings under Advanced -> Video Intel IGD -> IGD Boot Type – here the display(s) to be used during boot up can be selected.

## 2.3 Software Installation

In general the software drivers required can be downloaded from the MSC support website under the Q7 module section :-

[www.msc-ge.com/support-boards](http://www.msc-ge.com/support-boards)

If you do not find what you need please contact our technical support group using the contact details described in section 3.

### 2.3.1 Windows XP

- Windows XP should normally be installed on a hard drive (eg. SATA) – for installation on a USB drive an application note is available from MSC – see sec. 3 for support contacts below.
- The following additional drivers need to be installed after installing the basic Windows XP (SP3) :
  - o Intel Chipset drivers – there is an executable installation file named : `infinst_autonl.exe`. Please follow the instructions.
  - o Intel LAN driver (Pro 1000) for 82574 – see `PRO2KXP-vxx_y_Intel.exe` installation file (Note version `vxx_y` will vary depending on latest release). After installing the LAN driver, the LAN connection may be used – Note: please check if any proxy setting is needed on your network for internet access.
  - o Intel Graphics media Accelerator (GMA) 500 software. These drivers can be downloaded from the MSC website – there is a setup program included which performs the update automatically.
  - o Graphics drivers – run the setup file included with the graphics drivers to install the Intel GMA500 drivers.

NOTE : After installing the drivers you may see an effect where the screen is blank – the display can be restored using the Ctrl + Alt + Fx keys combination. Where Fx can be F1 to F4 depending on the display type attached (VGA, DVI or TFT). After pressing a key combination you should wait at least 10 seconds to see if the display re-appears.

Ctrl + Alt + F1 – for VGA

Ctrl + Alt + F3 – for LCD Panel

Ctrl + Alt + F4 – for DVI

- o Audio drivers for the Realtek High Definition Audio codec. In order to enable the High Definition Audio jumper J1001 must be installed. Run the `setup.exe` file included with the drivers. Whenever a connection is made to the audio connectors, the Realtek audio driver interface will be automatically started.
- o USB Client drivers for the client USB mini AB interface on connector X6. In order to use the USB Client device for connector X6 jumpers J0901 and J0902 should be setup appropriately. (see user manual).

For the driver installation please refer to the Intel USBC\_ReleaseNotes document included with the driver package.

NOTE : Following drivers should only be installed where the hardware feature is supported. For example the MSC Q7-US15W-001 does NOT have a PCIe to SATA bridge.

- o SATA drivers for the JMicron PCIe to SATA II bridge device – run the `setup.exe` file included with the drivers.

- Windows XP on USB memory Stick – an application note is available on request which describes techniques to transfer a Windows XP installation to a USB memory stick.

### **2.3.2 Linux**

- The UBUNTU release 9.04 has been successfully installed on the MSC Q7 system. This release or later versions should be used in order to include support for the Intel US15W chipset.
- For more details on Ubuntu and software downloads / upgrades please go to :
- <http://www.ubuntu.com/>
- Linux on USB memory Stick – Linux can also be directly installed onto a USB memory stick.
- Linux on SDIO card – an application note is available on request which assists with the installation of Linux onto an SDIO card.

### **2.3.3 Windows CE 6.0**

- A windows CE 6.0 BSP for Q7 is available on request.

### **2.3.4 Windows XPembedded / Windows Embedded Standard**

- Support is available on request.

### 3 Product Support

MSC engineers and technicians are committed to provide support to our customers whenever needed.

Before contacting Technical Support of MSC Vertriebs GmbH, please consult the respective pages on our web site at [www.msc-ge.com/support-boards](http://www.msc-ge.com/support-boards) for the latest documentation, drivers and software downloads. If the information provided there does not solve your problem, please contact our

Technical Support:

Email: [support.boards@msc-ge.com](mailto:support.boards@msc-ge.com)

Phone: +49 8165 906-200