

BASIC IO-LINK TRANSCEIVER

E981.10

Features

- ▶ Supply voltage range 8 - 36 V
- ▶ Integrated 5V voltage regulator
- ▶ Wakeup detection
- ▶ Driver capability up to 200mA
- ▶ C/Q reverse polarity protection
- ▶ 3.3V / 5V compatible digital interface
- ▶ Baud rate selection up to 230kbit/s
- ▶ Load current monitor and overcurrent protection
- ▶ Overtemperature protection
- ▶ Junction temperature up to +150°C
- ▶ QFN 4x4 package, exposed die pad, $R_{\text{THJA}} < 35 \text{ K/W}$

Brief Functional Description

The IC is intended to be used as transceiver in IO-Link and SIO-mode applications in sensors and actuator devices. The communication and the power supply works across 3 separate lines to the IO-Link Master. The integrated voltage regulator is able to provide 5V for external purposes.

The E981.10 is the first member of the IO-Link family of ELMOS. The IO-Link transceiver^{plus} - one of the next ELMOS devices on the roadmap - is an intelligent transceiver with frame handler powered by NEC Electronics.

Applications

IO-Link is a point-to-point interface between existing field busses and sensor/actuator devices. IO-Link serves the transmission of specific parameters or data, like diagnosis informations.

In addition, other application specific concepts based on ELMOS mixed signal expertise and NEC Electronics knowhow can be developed and provided on request.

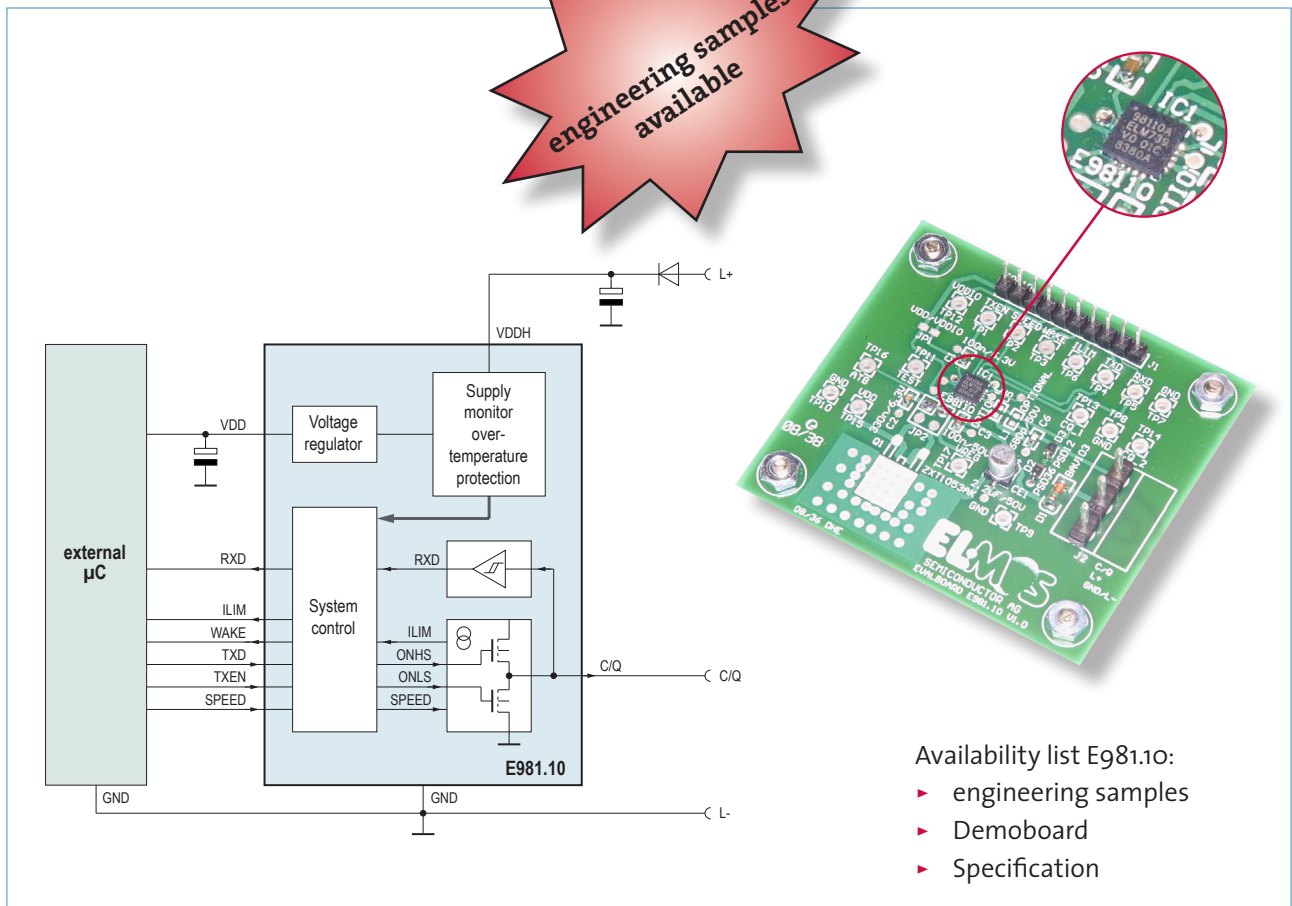
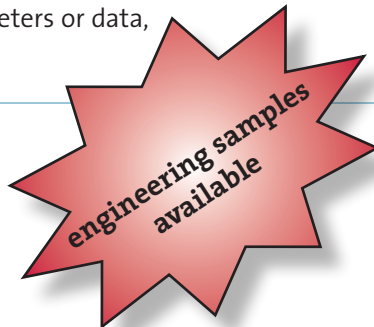

- Availability list E981.10:
- ▶ engineering samples
 - ▶ Demoboard
 - ▶ Specification

ELMOS Semiconductor AG – Headquarters
Heinrich-Hertz-Str. 1 | 44227 Dortmund | Germany
Phone +49 (0) 231-75 49-0 | Fax +49 (0) 231-75 49-149
sales@elmos.de | www.elmos.de

Direct IO-Link support:
christian.schmitz@elmos.eu

Note ELMOS Semiconductor AG (below ELMOS) reserves the right to make changes to the product contained in this publication without notice. ELMOS assumes no responsibility for the use of any circuits described herein, conveys no licence under any patent or other right, and makes no representation that the circuits are free of patent infringement. While the information in this publication has been checked, no responsibility, however, is assumed for inaccuracies. ELMOS does not recommend the use of any of its products in life support applications where the failure or malfunction of the product can reasonably be expected to cause failure of a life-support system or to significantly affect its safety or effectiveness. Products are not authorized for use in such applications.

Copyright © 2008 ELMOS. Reproduction, in part or whole, without the prior written consent of ELMOS, is prohibited.