

GLEICHMANN Newsletter

Empowered by Innovation



What a wonderful world ...

Once a year, Germany is the hub of the embedded world and an international platform for hardware and software as well as tools and services in the field of embedded technologies. Gleichmann Electronics is of course also there when the "embedded world 2008" opens its doors in Nuremberg, Germany, for three days 26 – 28 February 2008. We are looking forward to welcoming you at our joint MSC Gleichmann Booth 235 in Hall 9 and present to you the latest trends, technologies and design-in tips in the fields of Building Management, Health Care, Industrial Automation and Motor Control. Furthermore, we would also like to present to you a number of new innovative products. Special focus this time are the topics displays and

optoelectronics. As authorized distribution partner of Ampire, Alder, AUO, Clover, Elec & Eltek, eTurbo Touch, Hantouch, Harvatek, Hexa-Chain, i-sft, Kontron, Microtouch, NEC Electronics, Promate, RCL, Truly and Zytronic, we have an almost complete product portfolio. In addition, we are also able for the first time to offer our in-house

brand GE Vision, a broad range of reasonably priced standard LCD modules with customer specific modifications. Our fresh from the press 160-page GE Vision product catalogue provides information about our diverse product range as well as our comprehensive service offering and is available at our booth for you to take with you.



(Continued on page 2)

Agreement completed with Solomon Systech

It is not only well-known among expert users that Gleichmann Electronics holds a leading role in Europe as a provider of intelligent display solutions. For a long time now, leading manufacturers also value the professional competence of our display specialists and rely on the long-standing product and comprehensive applications know-how of our sales engineers when planning their expansion.

Latest proof of this is the recently signed pan European distribution agree-



Patrick Nolan: "All parties benefit from the pan European cooperation between Solomon Systech and Gleichmann Electronics, but particularly the customers."

ment with Solomon Systech Limited. The company is one of the leading international manufacturers of classic LCD drivers and at the same



Kristian Sans: "Both the display driver ICs and the graphic controller family from Solomon Systech are an optimal addition to our existing display portfolio."

time is worldwide the largest provider of OLED and Electronic Paper (E-Paper) display drivers.

(Continued on page 2)

Spotlights

Panasonic Li-ion batteries: Production still limited

The fire at the manufacturing plant of Matsushita Battery Industrial Co., Ltd. (MBI) in Osaka, Japan on September 30, 2007 is still showing massive after-effects. Although the production of lithium-ion batteries was resumed in November, full production capability is not expected to be reached again until May of 2008, at the earliest. We will be happy to answer your questions regarding alternative products at: batteries@msc-ge.com Tel. +49 711 78336-173



The latest LCDs and TFTs at a glance

Size, resolution, contrast, power consumption, price – the very latest, with up-to-the-minute information, product catalogues from GE Vision and NEC LCD Technologies help you to quickly and reliably find the optimal display for your application. Please contact us for further information.

Highlights

- SSD1906 Graphic Controller fulfills information display needs
- MCU family sets new standards in low power consumption
- P-channel MOSFETs – a useful alternative
- Clean energy: "Amorton" solar cells and many more ...

What a wonderful world ... (Continued from page 1)

Also available at our booth is NEC LCD Technologies' brand-new TFT brochure.

The importance of displays and optoelectronics for us is emphasized by the recently signed pan-European distribution agreement with Solomon Systech Limited. The company is one of the leading international manufacturers of classic LCD drivers and at the same time is worldwide the largest provider of OLED and Electronic Paper

(E-Paper) display drivers. Furthermore, Solomon Systech has a portfolio of powerful external graphic controllers such as the SSD1906, which we present to you in this Newsletter starting on page 2 and on 26 February live at our booth at embedded world.

Once again, we also have a lot of interesting products to offer in the field of high-end MCUs. In addition to NEC Electronics' CAN, ERTEC and ZigBee derivatives, another high-

light is NEC Electronics' new V850ES/Jx3-L 32 bit microcontroller family. The devices, which require only 0.9 mW/DMIPS of power in active mode and draw as little as 1.5 µA in stop mode, set new standards in low power consumption for battery-driven applications. Detailed preliminary information about these devices can be found on page 5 of this Newsletter. Have we aroused your curiosity? Do you have questions? Come visit us at

our joint MSC Gleichmann Booth 235 in Hall 9 at "embedded world 2008" in Nuremberg, Germany, 26 – 28 February 2008. We invite you to join us at our booth to meet our experts and enjoy our hospitality. We will happily present to you the latest innovations and give you lots of valuable product advice.



Agreement completed with Solomon Systech (Continued from page 1)

Furthermore, Solomon Systech has a portfolio of powerful external graphic controllers, which are used in numerous consumer and industrial applications. Because an increasing number of functions are implemented via the graphic user interface (GUI), the demand for external graphic controllers is also rapidly increasing. Detailed information on this topic can be found in the following article.

Solomon Systech has evolved as the largest Chinese "fabless" semiconductor manufacturer and Patrick Nolan, European

Director of Solomon Systech, places the company's presence in Europe in the foreground during the next years of expansion. "In the past, we already had some local distributors, but in important countries such as Germany, France and Turkey or in regions such as Eastern Europe a technically competent and logistically strong partner was missing." The selection of Gleichmann Electronics and MSC was not a coincidence. "We obviously looked closely at many potential candidates before making our decision," said Nolan. "But in the end, the determining factor was

that Gleichmann Electronics, like Solomon Systech, is focused on only a few market segments. Continuous top performance over a long period of time can only be achieved by those companies that are focused. In this point, the philosophies of our companies coincide excellently with each other. All parties benefit from the pan-European cooperation between Solomon Systech and Gleichmann Electronics, but particularly the customers."

Kristian Sans, European Product Manager of Gleichmann Electronics, responsible for the marketing of

Solomon Systech products, sees this as a win-win situation for all parties. "We have set ourselves the goal of being able to offer all TFTs, LCDs, LCD modules and OLEDs also as complete solutions, including customer specific control right up to complete display designs. Both the display driver ICs and the graphic controller family from Solomon Systech are therefore, an optimal addition to our existing display portfolio."



SSD1906 Graphic Controller fulfills information display needs

In the 21st century, graphic display has become a key component of today's electronic appliances and a necessity in the mindset of consumers.

Evolving from a simple text-based user interface with minimal animations, large display and rich content display rendering

in stunning high resolution have set the trend for the new generation.

The potential opportunities for the graphic controller are vast. We are able to support most of the resolutions commonly used in today's electronic appliances, from monochrome black/white up to 262K colors.

The graphic controller is capable of handling high performance displays with different color and resolution requirements, from 320 x 240 (QVGA) with 65K colors, which is a universal configuration for hand-held terminals, vending machines and a lot more different industrial applications,

to the much larger display panel seen in 800 x 600 16 gray scale point-of-sales machines or a registration terminal.

The advanced design of the graphic controller provides a low-cost, low-power solution to enhance graphic display performance. When used alongside LCD mod-

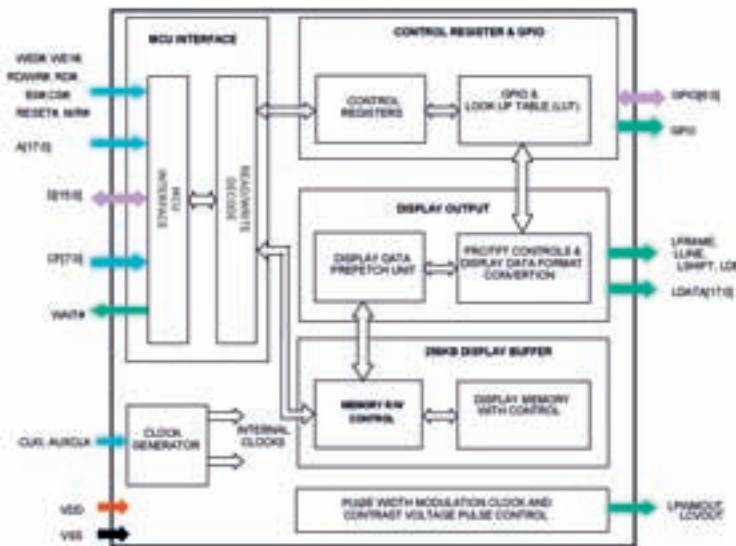

Figure 1. Functional blocks in SSD1906 LCD Graphic Controller

ules, the graphic controller supports higher resolution and higher color depth, and when bundled with low-end MCU, supports more fancy and attractive 2D graphic features.

With cost often being a critical concern in technology development, lowering the design cost makes the graphic controller more universal. If we think back to the first generation LCD which appeared on calculators, game sets and watches, capabilities have come a long way. The impact of cost has no doubt contributed to the development and demand of today's LCD based technology.

General description

Solomon Systech's SSD1906 is a graphic controller with built-in 256Kbyte SRAM display buffer, supporting color and mono LCD. The SSD1906 can support a wide range of active and passive panels and interface with various CPUs. The advanced design, together with integrated memory and timing circuits, produces a low-cost, low-power, single-chip solution

for hand-held devices or appliances.

Features



Figure 2: Virtual Display

In the past, graphic manipulation via pure software implementation was cumbersome and tedious to say the least. Today, with its ability to display full color rich information on an LCD panel, the graphic controller has become a bridge between the microprocessor, the display panel and the driver.

The SSD1906 Graphic Controller integrates an embedded 256K byte SRAM display buffer, graphic engine and timing circuits into a single chip (Figure 1).

More advanced than the 80K byte embedded

SRAM display buffer in SSD1905, SSD1906 possesses a contiguous 256Kbyte frame buffer. High resolution, full color display for price checkers, barcode and professional audio equipment are now a reality. To keep pace with the technology, the graphic controller supports an enlarged display buffer, higher resolution panel, with a color depth of up to 16bpp, and a maximum 262K colors.

A single power supply, rather than two separate CoreVDD and IOVDD supply voltages, helps to simplify hardware circuitry design by minimizing the number of components and resulting in lowered design costs.

The built-in graphic engine is headlined with hardware display image rotation of 90°, 180° and 270° counter-

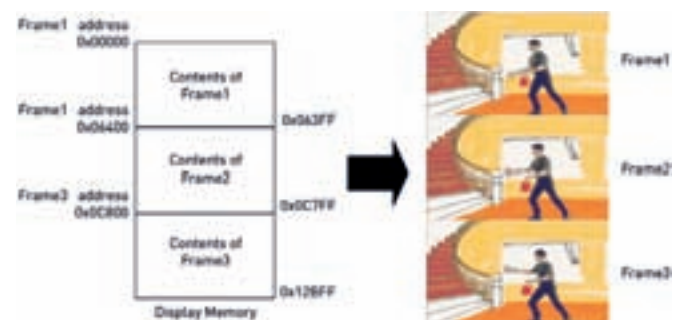

Figure 3: Multi-pages buffering

clockwise to support different form factor needs. This feature provides varied LCD

viewing orientation and also has performance advantage over software rotation, where the entire display buffer has to be rewritten every time, displaying image in a slower and less efficient way. The on-chip graphic engine also features virtual display (Figure 2), allowing images larger than the panel size to be viewed through the use of panning and scrolling. With this feature, users can freely display portions of an image in portable devices, reducing the need for the CPU to rewrite the entire display buffer during viewing window movement in software implementation.

The floating window feature of the graphic controller allows users to overlay variable sized windows on the main frame, fulfilling the high demand for multi-tasking graphic applications. Memory is allocated separately for main and floating windows, thus eliminating corruption background image when moving the overlaid floating window.

Two simultaneous hardware cursors for 4/8/16 bpp reduce the software manipulation. With this feature enabled, a maximum two

4-colored (include transparent) blinking or static cursors can be overlaid on

| | Sleep Mode (Clock halt) | Power Saving Mode (Display off, Clock active) | Operating Mode (Display Enable) | Operating Mode (Display Enable) |
|---------------------|-------------------------|---|---------------------------------|---------------------------------|
| CLKI (MHz) | - | 16.6 | 16.6 | 16.6 |
| PCLK/CLKI | - | - | 1/8 | 1 |
| PCLK (MHz) | - | - | 2 | 16.6 |
| Color Depth (bpp) | - | - | 8 | 8 |
| IOVDD (V) | 3.3 | 3.3 | 3.3 | 3.3 |
| Typical current (A) | 60u | 400u | 2m | 11m |

Figure 4: SSD1906 power consumption

the main display area. Double/multi-pages buffering (Figure 3) enhances video frame display quality. SRAM buffer memory is divided into two or more sectors, filling in the video frame contents into the sectors in sequence. Displaying one sector while updating the rest, results appear in smooth motion display. The 32-bit internal data path provides high bandwidth display memory for fast screen updates.

Integrated MCU and LCD interfaces

Minimizing application development time is a main concern for the engineer. An LCD graphic controller which has in-built MCU and LCD interfaces lessens the design effort. Solomon Systech's SSD1906 Graphic Controller supports 13 types of monochrome and color, active and passive LCD panels, including 4/8-bit monochrome/color STN, 9/12/18-bit active matrix TFT and direct support for 18-bit Sharp HR-TFT (160x160, 320x240). It also provides a direct interface to high-end and low-end CPUs, with a standard 8/16-bit memory interface.

Dynamic dithering

Frame rate control (FRC) and static dithering are two conventional methods for

shade level generation used in the graphic controller. FRC is achieved by controlling on and off pixels over

| | SSD1906 |
|----------------------------------|-----------------------|
| Embedded Display Buffer | 256K Bytes |
| Color Depth | 1/2/4/8/16 bpp |
| Display Support | |
| - Analog TFT | - |
| - 4/8bit STN interface | ■ |
| - 4/8bit CSTN interface | ■ |
| - 9/12bit TFT interface | ■ |
| - 18bit TFT interface | ■ |
| - Sharp HR-TFT interface | ■ |
| Display Mode | |
| - Horizontal Resolution Doubling | - |
| - Virtual Display | ■ |
| - Display Rotate Mode | ■ |
| - Floating Window | ■ |
| - Display Color Invert | ■ |
| - Display Blank | ■ |
| - 2 Hardware Cursor | ■ |
| - Multi-pages Buffering | ■ |
| Miscellaneous | |
| - PWM and CV | ■ |
| - GPIO pins | Max. 7 GPIO and 1 GPO |
| - Package | 100 TQFP 100 TFBGA |
| Status | MP |

SSD1906 features

multiple frames, where static dithering regulates the number of on and off pixels in a small defined pixel group, filling each on pixel with the resultant FRC shade level. Both FRC and dithering are only applied on monochrome/color passive STN LCD panels. One drawback of static dithering is a blocked image and undetermined display resolution. Dynamic dithering mode, which changes patterns with the same gray level from time to time to average out this unpleasant blocky effect, is a feature of the SSD1906.

Power consumption

Power consumption is a crucial concern in design.

Lowering the power consumption can extend the battery life, making hand-held devices more attractive to consumers.

The power consumption depends on many parameters e.g. the pixel clock, color depth etc. An example in real application is when SSD1906 the graphic controller operates at a lowered color

depth, 2bpp, reducing power consumption to 2.5mA, under the following condition: IOVDD=3.3V, CLKI =16.6MHz, PCLK=CLK1/8, 160x160HRTFT. In many applications, such as battery powered equipment, standby current is of great importance. The SSD1906 provides different standby modes. More reference power consumption data are shown in Figure 4.

External vs. built-in graphic controller

LCD graphic display with external graphic controller has remarkable advantages

over the built-in version available in high-end MCU/RISC. Based on research statistics, bundling external graphic controller with low-end to mid-end MCU/RISC can sharply reduce costs within the range of approximately US\$5 to US\$18, thus directly reducing the design-in expense.

The external graphic controller enhances the performance of the microcontroller by dividing the workload between the two. A microcontroller with built-in graphic controller needs much more performance and power in comparison to a smaller microcontroller. This of course will increase the price of the microcontroller and the whole system; very often the system costs are lower with an external graphic controller. For design engineers it is much easier for them to make their design, because they do not need to compromise the display refresh rate with performance of the microcontroller.

Conclusion

Battery driven applications is one of the hottest topics in electronics. Video and audio elements are being integrated into the display system, bringing multimedia features to a climax. The advanced design of the graphic controller is inevitably a necessary component in low-cost, low-power, color information graphic display in modern applications.

 +49 711 78336-115
ksan@msc-ge.com.com
Response number 154

MCU family sets new standards in low power consumption

The new V850ES/Jx3-L 32 bit microcontroller family, a further enhancement to NEC Electronics' All Flash microcontroller line-up, features extremely low power consumption. The devices require only 0.9 mW/DMIPS of power in active mode and draw as little as 1.5 μ A in stop mode.

Despite low power consumption, the V850ES/Jx3-L family makes no compromise on performance or peripherals. The 32 bit microcontrollers are based on the popular V850ES RISC CPU core running at up to 20 MHz and provide either 128KB or 256KB of Flash memory and up to 16KB of embedded RAM. Thanks to their highly efficient pipeline architecture and integrated DSP functions, the devices are capable of high-end mathematical operations.

Moreover, the V850ES/Jx3-L family offers a number of on-chip features, which contribute to

reducing component count and system cost whilst at the same time increasing system reliability. Watch-dog, power-on reset and low-voltage detection are standard. Despite low voltage operation of 2.2 V to 3.6 V, the V850ES/Jx3-L family offers 5V-tolerant I/O ports, hence making an additional cost saving on



external level shifters. Furthermore, the new microcontroller family includes seven serial communications channels, which allow a flexible selection of the operating mode and the required functions. Numerous UARTs, I²C interfaces or clocked serial interface (CSI) are available to the user.

Additional features of the V850ES/Jx3-L family include an integrated cyclic redundancy check (CRC) circuit and a hardware multiplier for faster algorithm execution. An external bus interface for additional memory expansion, highly flexible one and three phase 16-bit timers, watch timer, up to 12 channels for A/D conversion and up to two channels for D/A conversion, a DMA controller with four independent DMA channels and on-chip debug functions complete the highly efficient chip design.

The new V850ES/Jx3-L 32 bit microcontroller family offers new levels of energy saving to power-sensitive applications such as multi-phase electricity meters, high-end blood glucose meters, ZigBee routers, gateways, point of sale terminals or test and measurement equipment.

The V850ES/Jx3-L family is pin and functional compatible to existing generations of the V850 All Flash range. The 80-pin package and 12 mm² (LQFP fine pitch) as well as 14 mm² (standard package) contribute to a reduction in the size of portable equipment. An optional 100-pin version in a 14 mm² LQFP fine pitch or a 14 x 20 mm package is also available. In addition to compiler suites from IAR Systems and Green Hills, a number of different tools – including a starter kit MINICUBE2 for on-chip debugging, IECUBE for full trace and emulation and the new PG-FP5 Flash programmer – are available to the user for development. The starter kit and first samples of the V850ES/Jx3L family are available now from Gleichmann Electronics. Mass production is expected to begin in March of 2008.

+49 711 78336-149
NECMicro@msc-ge.com
Response number 155

P-channel MOSFETs – a useful alternative

Almost everyone has experienced it: You need to construct a simple circuit e.g. reverse polarity protection, battery switch or a motor control. The basic circuit is usually quickly created, but on close examination of the approach to a solution there is often some doubt. Is the attempt at a solution too complex? Is the solution in this form commercially acceptable?

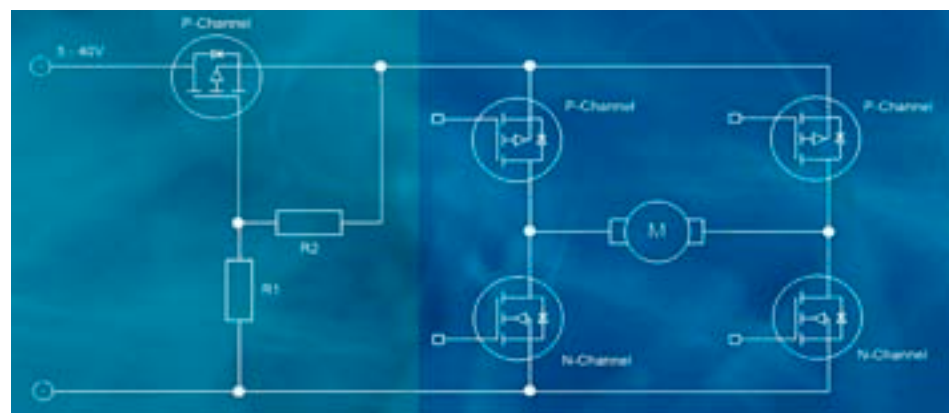

Reverse polarity protection using p_channel MOSFET

Application

A common example, which is often experienced, is the control of an n-channel MOSFET, which has to be located in the Vcc line. Skilled designers know that this process contains many pitfalls and in the end can not be solved without complicated circuits or special components with so-called bootstrap function. Let's remind ourselves: To switch an n-channel transistor requires a 4 to 10 V higher gate voltage than the source voltage. For this reason an additional voltage is required, which is therefore associated with expenditure of time and material costs. Additional costs for a 'simple' reverse polarity protection of a battery-powered device or battery charger? This breaks all rational commercial barriers. Therefore, change the circuit concept?

The simplest and most obvious approach is, of course, the series connection of a power diode. However, this solution has the serious disadvantage that it has 0.4 to 1V voltage drop. At the same time, dependent on power requirements, not insignificant heat and therefore

the integration of a relay with diode in the control circuit. This fairly simple solution, whereby almost no voltage drop occurs, can also be implemented with comparatively little effort. The problem with this is that the relay only switches with a positive voltage on the positive pole. In addition to the less than 100 percent reliability of the relay, it is furthermore often the large space required for the housing, which is against this comparatively cost-effective solution. A simple, reliable and modern alternative still remains - the use of a p-channel MOSFET.

However, just the thought of this causes many designers' hair to stand on end. Whether it is switching time, track resistance or price; essentially there are almost no points in which p-channel MOSFETs do not compare unfavorably

today the way students are taught. P-channel MOSFETs, particularly in the range <100 V, have benefited in the past years from a rapid technology race to catch up. In the meantime, p-channel products are offered that exhibit 3.5 mΩ channel resistance

important advantages compared to circuits with n-channel transistors. Firstly, with a p-channel configuration that serves as reverse polarity protection the control unit can be firmly connected to ground in order to safeguard the designer from a 'floating' earth (ground). Secondly,

P-Channel NP-Series in UMOS-4

| V _{DS} [V] | R _{DS(on) max. [mΩ] @ V_{GS} =} | | I _D [A] | P _D [W] @ T _c = 25°C | SMD | |
|---------------------|--|-------|--------------------|--|-------------|-------------|
| | 10 V | 4.5 V | | | TO-252ZK | TO-263ZK/ZP |
| 40 | 4.2 | 61 | -15 | 15 | NP15P045IG* | |
| | 28 | 40 | -20 | 45 | NP20P045IG* | |
| | 17.5 | 25 | -30 | 50 | NP30P045IG* | |
| | 17 | 23.5 | -30 | 50 | | NP30P04EDG |
| | 10.5 | 15.5 | -50 | 90 | NP50P045IG* | |
| | 10 | 15 | -50 | 90 | | NP50P04EDG |
| | 5.3 | 8 | -81 | 150 | | NP83P04PDG |
| | 3.5 | 5.1 | -100 | 200 | | NP100P04PDG |
| 60 | 7.5 | 38 | -15 | 15 | NP15P065IG* | |
| | 50 | 64 | -20 | 45 | NP20P065IG* | |
| | 30 | 40 | -30 | 50 | NP30P065IG* | |
| | 19.5 | 17.5 | -30 | 50 | | NP30P06EDG |
| | 17.5 | 23.5 | -30 | 90 | NP50P065IG* | |
| | 17 | 23 | -30 | 90 | | NP50P06EDG |
| | 8.8 | 12 | -81 | 150 | | NP83P06PDG |
| | 6 | 7.8 | -100 | 200 | | NP100P06PDG |

* Product in under development and might be subject to change without notice. NEC

NEC Electronics' p-channel MOSFET product portfolio

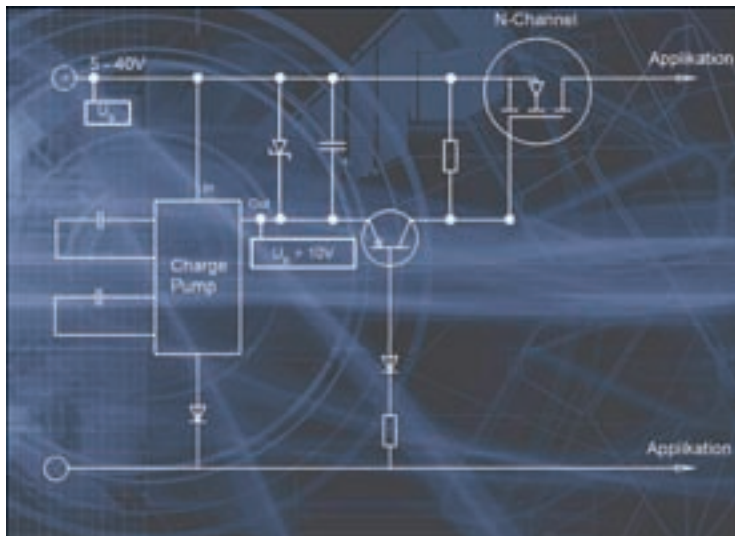

Reverse polarity protection using n_channel MOSFET

cooling problems are to be reckoned with.

An alternative to this is

to n-channel MOSFETs. This has been taught for decades and is, at least partially, even

with 40 V blocking voltage. These are values that a few years back, as a rule, even p-channel types could only just barely achieve.

Moreover, in the meantime p-channel transistors are today just as robust as we are accustomed to from n-channel devices. The 20 to 35 percent higher price is mostly offset by the saving in the overall circuit. The only remaining shortcoming is the switching speed, which compared to n-channel transistors is somewhat less. However, our experience shows that in many practical applications this point does not play a role.

In addition, there are two

no complex driving circuit is necessary for the implementation of a complementary H-bridge circuit for the p-channel high-side switch. This leads to a significant simplification of the circuit design.

In the recent past, Gleichmann Electronics has added a large number of p-channel MOSFETs from NEC Electronics to its product portfolio. There are many reasons for this. From our point of view, p-channel MOSFETs offer designers an as yet fully underrated, easily usable alternative for the optimization and improvement of circuit designs.

Additional information on this interesting topic is available at:

+49 711 78336-115
 power-devices@msc-ge.com
Response number 156

New p-channel PowerMOSFETs with RDS(on) down to 3.7m

NEC Electronics' latest devices in the NP series are designed for -15 A to -100 A drain currents. The p-channel PowerMOSFETs operate with drain source voltages from -40 and -60 VDS and logic gate drive. An additional feature of these low-voltage power management devices is the low on-state resistance value (RDS(on)). The on-state resistance value of NP50P04SDG and NP15P06SLG drain

current devices up to -50 A ID (DC) in the popular TO-252 package (DPAK) varies from 9.6 mΩ to 75

mΩ, while -100 A rated p-channel PowerMOSFETs in TO-263 package (D2PAK) extends down to 3.7 mΩ.

The maximum avalanche energy rating is device-dependent and ranges from 19 mJ to 550 mJ. Like all members of the NP series, the

new devices are qualified according to AEC-Q101. The devices support a maximum channel temperature of 175°C, and are fully RoHS compliant thanks to zinc (Sn) plating of the leads. For more information about these new p-channel PowerMOSFETs:

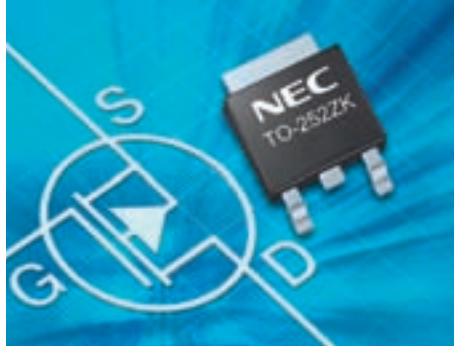

+49 211 92593-13
power-devices@msc-ge.com
Response number 157

High speed optocoupler series in 8-pin DIP package

Gleichmann Electronics presents NEC Electronics' new PS9587 series of high speed optocouplers with a GaAlAs LED on the input side and an open collector output.

The devices, available in eight different versions, are designed for high speed logic data interfaces with 5 V supply voltage line. The maximum propagation delay time (t_{PLH}/t_{PHL}) of 75 ns enables the transfer of data of up to 10 Mbit/s speed.

The optocouplers are

offered with 5000 Vrms isolation voltage, >0.4 mm isolation distance and, depending on the version, >7 mm or >8 mm outer creepage distance. The internal shield between input and output side guarantees a common mode transient immunity of minimum 15 kV/μs and typically 20kV/μs. The new PS9587 series of high speed optocouplers comply with current international safety certificates (UL, VDE, etc.). Furthermore, the devices use nickel-palladium-gold

(NiPdAu) as lead-free pin plating material and are fully RoHS-compliant.

The optocouplers are supplied in an 8-pin DIP package and are ideally suited for high speed communication interfaces, factory automation networks, test and measurement equipment and many other applications in harsh industrial



environments. Samples are available now.

+49 211 92593-13
power-devices@msc-ge.com
Response number 158

NEC Electronics expands CATV hybrid portfolio



NEC Electronics rounds off its current CATV portfolio

with various new 1 GHz and low-cost hybrids (U type).

Some of the latter have significantly improved ESD protection (SU type). In the 1 GHz range, power doubler hybrids with 18.5, 22.5, 24.5 and 27dB gain are also now included and are currently available from Gleichmann Electronics. Furthermore, the proven types MC7831, MC7832 and MC7833 as 1GHz push-pull versions are offered immediately. By the way, NEC Electronics is not

only expanding its product portfolio, but also its production facility. The more than 50 percent expansion of capacity should, at least temporarily, make sure that delivery times are reduced. More information about current types, prices and delivery times can be found at:

+49 89 945532-43
radio-frequency@msc-ge.com
Response number 159

NEC Electronics' new 2.4 GHz devices: Small but powerful

NEC Electronics' new 2.4 GHz HF switches and power amplifiers are optimally suited for use in Bluetooth, ZigBee, ISM, wireless USB and WLAN applications. With dimensions of only 1 x 1 x 0.37 mm, these devices are currently the world's smallest dual control switch. The uPG2158T5K can be operated with 1.8 V or 2.7 V supply voltage, whereby the switching power (Pin 0.1dB) is up to

24 dBm or 29 dBm, dependent on applied voltage. The device type uPG2160T5K is also available as single control switch.

We are also able to present to you a further highlight; the slightly larger dimensioned power amplifier uPG2250T5N, which is specially designed for 1.8 V applications. Despite a size of only 1.5 x 1.5 x 0.37 mm and the comparatively low current consumption of just

100 mA approximately, the device provides the user with an output power of 20 dBm typical. Even less current consumption of 65 mA is used by the 3 V power amplifier uPG2314T5N, which also provides an output power of 20 dBm typical. Both devices were primarily designed for Bluetooth, ZigBee and ISM designs.

The portfolio of new 2.4 GHz devices is rounded off with the switch devices uP-

G2162T5N, uPG212163T5N and uPG2164T5N as well as the power amplifiers uPG2315T5T and uPG2318T5N. All of these devices were specially designed for use in WLAN applications.

Further information is available at:

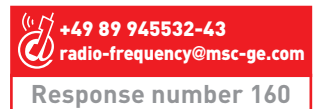

Harvatek high-power LEDs provide light spectacle



Not too long ago, it was possible to decorate buildings and places of interest, even in darkness, with standard high pressure lamps. One of the disadvantages of these lamps is that the change of color is only possible by means of costly mechanical changes of the filter. An expensive procedure that is completely redundant with the use of modern LED technology.



Innovative high-power LEDs, with the corresponding controls and programs, not only make fantastic color effects on buildings or other architectural objects possible, but also only require a fraction of the energy, which up till now was necessary for conventional high pressure lamps. With a 95 percent level of efficiency, LEDs can hardly be beaten when it comes to energy efficiency.

The shaft tower of the mine in Goettelborn, Saarland, Germany with a height of 87 meters is the highest of its type worldwide and, in the true sense of the

word, a shining example for successful architectural outside decoration lighting. The firm Keller & Meier in Friedrichsthal, Germany was responsible for the technical conception and execution of the project.

Special spotlights were designed and built, in order to achieve an optimal optical effect with the high-power LEDs provided from Gleich-



mann Electronics and optics provided from Keller & Meier. Since September 2007, 288 Harvatek HT-MBP278 LEDs in sixteen spotlights provide a fascinating regular evening light show. Using a combination of red, green, blue and white (RGBW) 2.5 W LEDs and by means of selected programs, almost all possible colors can be

created. The special configuration of the LEDs in the spotlights and the optimized optics, bath the floodlit object in a homogenous, flowing sea of colors.

By the way, the Harvatek LEDs used for this project are electronically limited to a maximum power dissipation of only 2 W, which significantly increases the already high service life. Simple

color changes, distinctly reduced energy costs compared to the use of high pressure lamps, higher investment security due to longer service life, minimal expenditure

for service and maintenance of the system – if you wish to know more about the advantages of Harvatek's high-power LEDs, we will happily send you the appropriate documentation.



Clean energy: “Amorton” solar cells

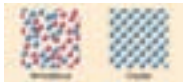

Figure 1: Amorphous silicon (a-Si) solar cells

As everyone knows, environmentally friendly, energy saving devices are becoming more and more important in today’s markets. Using solar cells to convert a light source into electrical energy is not only environmentally friendly, but also avoids waste by, for example, reducing the need to use disposable batteries. Last, but certainly not least, in the long-term it saves money.

Solar cells are classified according to the material employed, i.e., crystal silicon, amorphous silicon (a-Si), and compound semiconductor solar cells. “Amorphous” refers to objects having no definite shape and is defined as non-crystal material.

Unlike crystal silicon, in which atomic arrangements are regular, amorphous silicon (a-Si) features irregular atomic arrangements as shown in Figure 1. As a result, the reciprocal action between photons and silicon atoms occurs more frequently in amorphous silicon than in crystal silicon, allowing much more light to be absorbed.

Amorton is an integrated amorphous silicon solar cell which has been developed by SANYO. Amorton

uses silane (SiH₄) as its source gas and is fabricated using a plasma chemical vapor deposition (PCVD) method. Three amorphous silicon layers -- p-layer, i-layer, and n-layer -- are formed consecutively on a glass substrate. This p-i-n junction corresponds to the p/n junction of a crystal silicon solar cell. In the process of this junction for-

cal action between photons and silicon atoms.

At a p/n junction between two different semiconductor materials, the electrons are diffused in the n-type material and the positive holes are scattered in the p-type material. They are then collected at both electrodes respectively, resulting in a

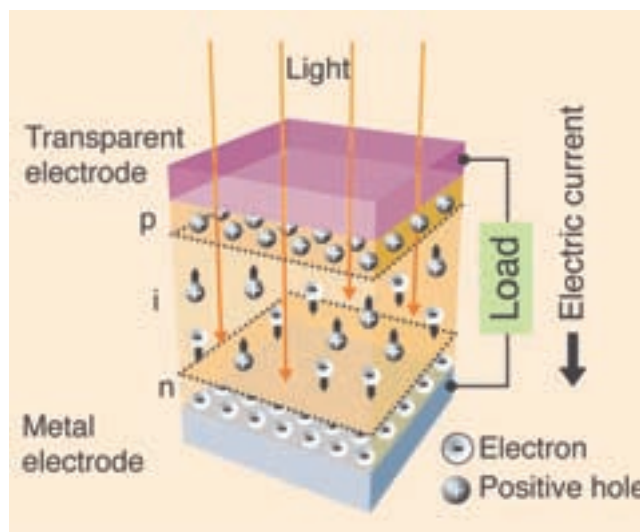

Figure 2: The concept behind solar cell power generation

mation, a number of cells are connected in series on a substrate at one time. This allows any desired voltage to be obtained for a variety of equipment operation.

Solar cell power is generated using the photovoltaic effect of semiconductors (Figure 2). When a semiconductor is exposed to a light source of suitable intensity, a large number of pairs of an electron and a positive hole are generated as a result of the recip-

rocal action between photons and silicon atoms.

When an external load is connected, electricity flows through the load. In this way, an amorphous silicon (a-Si) solar cell converts light energy into electricity and supplies power to external loads.

Benefits of amorphous products include an unlimited energy supply from sunlight free of charge; direct conversion of sunlight to electricity in a clean and noise-free man-

ner that does not produce toxic waste or by-products; regardless of the size of cells, power is generated at a fixed rate of optimum efficiency; power is generated whenever a light source is available, either natural, artificial, or diffused light.

SANYO amorphous products are used to power products such as calculators, thermometers, scales, battery chargers, deodorizers, wrist watches, clocks, stopwatches, LED flashing lights, sensor lights, remote control units, radios, testers, educational tools, fans, sun roof car fans, and many others.

Specifications of a small selection of the broad range of available products are shown in Figure 3.

A newly designed product is the AM-8801 with 30% increase in output current. Virtually any-shaped custom-made products can be fabricated with low initial cost.

The production of solar cells continues to boom and this trend is expected to last for many years. Solar cells open up new markets for solar energy, potentially powering everything. Gleichmann Electronics’ specialists can help you with innovative solutions for your future designs. More information on SANYO’s amorphous silicon (a-Si), solar cells can be found at:

| Model | Typical value (initial) 100mW/cm ² | Reference value (initial) SS 50KLux | External dimensions (mm) | Weight (g) |
|---------|--|--|-----------------------------|---------------|
| AM-5610 | 3.3V - 5.1mA | 3.0V - 2.3mA | 25.0 x 20.0 | 2.2 |
| AT-7664 | 3.0V - 104.0mA | 3.0V - 46.5mA | 73.0 x 112.0 | 4 |
| AM-5907 | 5.0V - 45.7mA | 5.0V - 20.6mA | 75.0 x 55.0 | 18.3 |

Figure 3: Specifications of a small selection of the broad range of available products

+49 711 78336-173
 batteries@msc-ge.com
Response number 162

Fast charge and extremely long-life: Lithium titanate

The discussion regarding lithium iron phosphate has not yet faded, but already a new material in the field of high-performance batteries is making the headlines: Lithium titanate.

Lithium titanate technology is since recently also used by our partner Batterien-Montage-Zentrum (BMZ) for the design of high-performance batteries. The technology replaces conventional graphite with a nanostructured lithium titanate anode. Because lithium titanate nanocrystals are extremely coarse-grained, one gram of this material is enough to generate an area of 100 square meters. This is more than thirty times than is possible with conventional materials.

Furthermore, the nanotechnology prevents the formation of a lithium ion impermeable top surface layer on the electrode ("solid-electrolyte interphase" SEI). Therefore, lithium ions can more easily reach the surface of the electrode.

Up to 20,000 charge and discharge cycles, a fast charge of only six minutes approximately and an operating range of -50°C to +75°C make the explosion-proof, lithium titanate cells an ideal choice for use in applications such as power tools, hybrid-electric vehicles (HEVs), electric vehicles (EVs), emergency power supplies and in telecommunications e.g. cell-phone/camera.

Reminder & latest News



Nickel cadmium (NiCd) batteries banned from September 2008

It would appear that the topic has been forgotten, but nonetheless the countdown is running: In accordance with Article 4, paragraph 1 and Article 26, paragraph 1 of Directive 2006/66/EG of the European Parliament, as from 26 September 2008 the placing on the market

of certain batteries and accumulators containing mercury or cadmium is prohibited. Nickel cadmium (NiCd) batteries are then definitely banned. Directive 2006/66/EG was issued by the European Parliament on 26

September 2006 and gave the EU Member States 24 months for the implementation of the Directive, in accordance with their corresponding national law. For further information please contact:

 +49 711 78336-173
batteries@msc-ge.com
Response number 163

DESIGN & ELEKTRONIK
ENTWICKLERFORUM
6. März 2008
FH MÜNCHEN

Mobile without boundaries? Our experts will disclose to you how it works. On March 6, 2008 at the Design&Elektronik-Entwicklerforum (Development Forum) in Munich, Germany or April 9/10 at the Battery

Forum in Aschaffenburg, Germany.

Notebooks, mobile telephones, golf carts, hammer drills, motorboats, vacuum cleaners, mixers, mobile medical equipment – the number of applications powered by primary (disposable) batteries and secondary (rechargeable) batteries has increased dramatically in the past years and nonetheless, we are only at

the beginning of a fascinating technological development.

Don't miss being there with the who's who of the battery industry. Experts from Ansmann, BMZ, Panasonic, Saft, Sanyo and many other manufacturers will present to you the latest developments, particularly in the field of lithium-ion technologies.

The complete program

www.battery
university.eu

of events, to be held in Germany, as well as additional information associated with the topic portable and mobile power supplies can be obtained at phone:

 +49 711 78336-173
batteries@msc-ge.com
Response number 164

Talking sensors – IO-Link, the new standard in intelligent sensor communications

With a huge number of proprietary sensor communication systems in the Industrial Automation market, it was inevitable that a standard was on the horizon. IO-Link

has been lifted to dizzy new heights by some of the largest automation and sensor equipment manufacturers today. NEC Electronics, as one of the leaders in the Industrial

Automation semiconductor market, is able to address customers' requirements for IO-Link based intelligent sensor applications. These sophisticated, intelligent sen-

sors for the most part include embedded microcontrollers for parameterisation, precise sensor adjustments as well as expanded diagnostics features. With the addition of

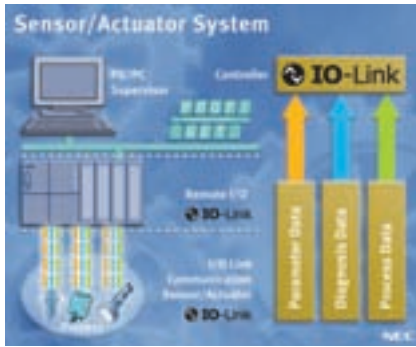

IO-Link to handle switching signals (process data) and also the exchange of parameter and diagnostics data (request data) with the sensor, this is even more relevant.

More efficiency, low cost

IO-Link is an enhancement to the I/O assembly-sensor interface that enables more efficient, standardised communications while maintaining low cost. The standard is a fieldbus-independent sensor/actuator communication system, developed by a consortium of sensor companies and administered by Profibus International. It is defined as a point-to-point connection between sensor/actuator (Slave), and the I/O module or PLC (Master). It enables the combination of different units and controllers and preserves backward compatibility with older designs. A user can connect most existing fieldbus or PLC I/O modules that do not have an IO-Link port to an IO-Link unit. The IO-Link sensors

will then only work in the standard I/O mode with a binary switching signal. A new fieldbus module with IO-Link ports is necessary if the user wants to benefit from the extended online diagnostic features that may be of-

fered by the sensor. Conversely, a conventional sensor that does not have an IO-Link port can be connected to a remote I/O that does have an IO-link port.

IO-Link sensors use three types of communication: switching status (binary, like conventional sensors), cyclical process data (e.g. digital transmission of measured values), acyclic transfer of device parameters and diagnosis data. Communication between master and slave is possible, by using up to three communications speeds (4.8, 38.4, 230 kBauds), in a typical 2 ms cycle time. The signal transmission is based on a 24 V pulse modulation with standard UART protocol in half duplex mode, for a distance of up to 20 metres long on a standard 2 or 3-wire M5, M8, M12 connection cable. Furthermore, as IO-Link is a standard and offers users the ability to save parameter data, sensors can be replaced quickly and easily. Parameterisation data can be read from the sensor, stored,

and in case of a replacement loaded to a new sensor of the same type even from a different manufacturer. This manipulation can be done within an ongoing process, reducing system downtime.

To show that IO-Link can be integrated easily the specification includes mappings for Profibus DP, Interbus and Profi-

net. Sensor companies have already started to release Profibus compatible PLCs with integrated IO-Link ports. NEC Electronics positions itself as a solutions provider for designers by offering an exhaustive range of devices suitable to IO-Link applications. Software for IO-Link can be delivered by third party partners, names of which can be supplied upon further enquiries. For Master modules, a low cost 32-bit microcontroller from the V850 family can be used to introduce the intelligence and number of ports required. Modules with 4 and 8 ports are being released by remote I/O manufacturers. NEC Electronics gives you the advantage of the large range of 32-bit microcontrollers with up to 8 integrated UARTs. For

connection to the Ethernet network of your design, our ERTEC solution gives you compatibility to the Profinet technology. For sensors (slaves or devices), designers have a choice of low pin count 8-bit and 16-bit controllers with integrated UARTS, up to 16 channels 10-bit A/D converters, and additional peripherals



to implement complex functions and achieve the precision required of today's automation systems.

Advantages of saving wiring

IO-Link gives the advantages of saving wiring by including diagnostic options of intelligent IO-Link sensors, compatibility with conventional units, and cost reduction in system implantation.

+49 711 78336-149
 NEC-Micro@msc-ge.com
Response number 165



Personal Profile of Roland Federle - Gleichmann & Co. Electronics GmbH

has two children a 17 year old daughter and a 19 year old son. He studied industrial engineering at the technical college in Karlsruhe, Germany.

Roland Federle is 49 years old, married, and

After working for 10 years in the Bosch organization, Roland started working for a well-known German distributor of liquid crystal displays (LCDs). He progressed to being a LCD specialist, which then led him to becoming product manager for approximately 10 years.

Roland joined Gleichmann in April of 2007 and started immediately selling to key accounts. In addition, he established three new display lines. Roland is line manager in the LCD marketing group for GE Vision, RCL Display Ltd. and Hexa-Chain. He is responsible for passive LCD sales in the

UK, France and Spain.

Roland enjoys skiing in winter, improving the technical status of his house and during the summer you will find him, as often as possible, on his boat on the Mediterranean Sea or on rivers and canals in Central Europe.

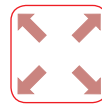

II-1_2008-R50-3480 ©GE

Our Commitment to Support

Please send me more information about:

- 8/16/32-bit Microcontroller and Tools
- SOC Light + (ARM based ASSPs)
- TFTs
- LCDs
- Power Mosfet
- Optocoupler
- Discrete Products
- ASICs
- RF (Radio Frequency)
- Gleichmann Linecard
- Gleichmann Batteries

Please send me detailed information about the following microcontroller topics:

- Building Management
- Motor Control
- Industrial Automation
- Health Care
- _____



Please copy and fax to +49 7249 910-328

| | |
|--------------|--|
| Name/Surname | |
| Company | |
| Department | |
| Address | |
| ZIP/City | |
| County | |
| Phone | |
| Fax | |
| E-mail | |
| Position | |
| Branch | |
| Company Size | |

Gleichmann Sales Offices
Headoffice Frankenthal
 Tel. +49 6233 347-0
 Frankenthal@msc-ge.com

Düsseldorf
 Tel. +49 211 92594-0
 Duesseeldorf@msc-ge.com

Eching
 Tel. +49 8165 9995-600
 GADE@msc-ge.com

Munich
 Tel. +49 89 945532-60
 GE.Muenchen@msc-ge.com

Stutensee
 Tel. +49 7249 910-0
 Stutensee@msc-ge.com

Stuttgart
 Tel. +49 711 78336-0
 Stuttgart@msc-ge.com

Gleichmann Sunrise UK Ltd.
 Tel. +44 1908 263999
 sales@ge-sunrise.com

Gleichmann Belgium
 Tel. +32 2 452 64 51
 Belgium@msc-ge.com

Gleichmann Ultratec AG
 Tel. +41 433 5533-66
 info@ge-ultratec.ch

Gleichmann Electronics Turkey
 Tel. +90 216 4112333
 Turkey@msc-ge.com

Gleichmann Electronics CZ s.r.o.
 Tel. +420 516 411494-15
 Blansko@msc-ge.com

Our products are also available through our sister company MSC

Berlin
 Tel. +49 30 720089-0
 Berlin@msc-ge.com

Hamburg
 Tel. +49 4106 7764-0
 Hamburg@msc-ge.com

Hannover
 Tel. +49 511 616847-0
 Hannover@msc-ge.com

Jena
 Tel. +49 3641 6825-0
 Jena@msc-ge.com

Wiesbaden
 Tel. +49 611 97320-0
 Wiesbaden@msc-ge.com

Nuremberg
 Tel. +49 911 43970-0
 Nuernberg@msc-ge.com

MSC Vertriebs GmbH
 Wiener Neudorf
 Tel. +43 2236 205066-0
 Wien@msc-ge.com

MSC Schweiz AG
 Tel. +41 21 965 3500
 Montreux@msc-ge.com

MSC-Vertriebs-CZ s.r.o.
 Tel. +420 296 580260
 Praha@msc-ge.com

MSC Iberia S.L.
 Tel. +34 93 582 44 45
 Barcelona@msc-ge.com

Tel. +34 91 721 69 51
 Madrid@msc-ge.com

MSC (France) S.A.R.L.
 Tel. +33 16480 5555
 Paris@msc-ge.com

MSC Budapest Kft.
 Tel. +36 1250 90-40
 Budapest@msc-ge.com

MSC Nederland BV
 Tel. +31 78 6920-150
 Netherlands@msc-ge.com

MSC Polska Sp. z o.o.
 Tel. +48 323 3054-50
 Gliwice@msc-ge.com

MSC-Mibatron s.r.l.
 Tel. +40 31 102 34 66
 +40 21 230 25 30
 Bucuresti@msc-ge.com

www.msc-ge.com



Contact your regional sales office