

# e2v

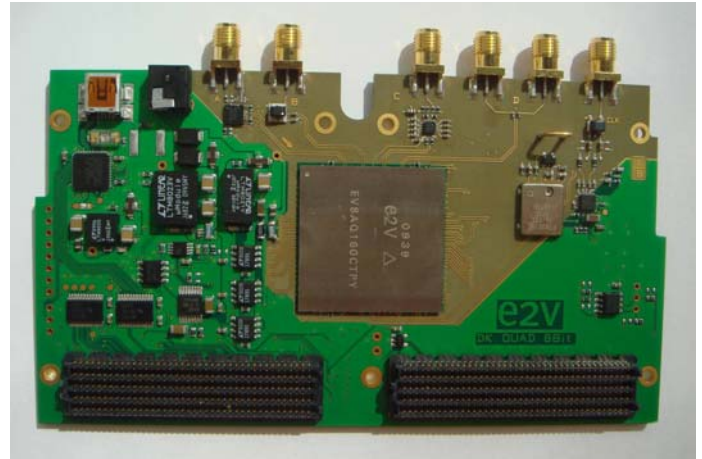

## Demo Kit Quad8 ADC EV8AQ160TPY-DK

### Summary Datasheet - Preliminary

#### Main Features

- Quad ADC with 8-bit resolution
  - 1.25 Gsps Sampling Rate in 4-channel mode
  - 2.5 Gsps Sampling Rate in 2-channel mode
  - 5 Gsps Sampling Rate in 1-channel mode
  - Built-in 4 to 4 cross point switch
- On board PLL generated 2.5 GHz Clock or/
- External Clock
- 4 analog inputs with different configurations
  - Differential driver (2 types of amplifier provided)
  - Balun RF transformer.
  - Direct input.
- VITA57 Standard Connectors
- Full compatibility with Xilinx ML605 Development Kit
- Control and Acquisition Display using P.C. based GUI
  - FFT computation (PC software provided)
  - Flexible and easy to operate via USB2 (PC software provided without any license)
  - Monitoring of ADC currents and junction temperature
- +12V supply adaptor supplied.

#### Operating conditions

- Temperature range:  $10^{\circ}\text{C} < T_{\text{amb}} < 40^{\circ}\text{C}$
- Operating with a Microsoft Windows PC environment (Windows 2000, Windows XP, Windows Vista) via USB interface.

#### Applications

- Demonstration and Evaluation of EV8AQ160 quad 8 bit analog to digital converter

## 1. General overview

The QUAD 8bit Demo Kit enables the easy evaluation of the characteristics and performance of ADC QUAD 8bit EV8AQ160. The Demo kit is plug\_and\_play and needs little external equipment.

The Demo kit is delivered with software which allows acquisition of data using the FPGA.

The QUAD 8bit Demo Kit is compatible with VITA57 FMC (FPGA Mezzanine Card) standard. The Demo kit QUAD 8bit is 100% compatible with XILINX VIRTEX 6 evaluation kit ML605

This board is designed for use as a reference design.

All front end devices are fitted including: DC-DC regulator, ADC driver, clock generator....

The FPGA VHDL data acquisition code for the ML605 board is supplied.

## 2. EV8AQ160 Block Diagram

Figure 1. Simplified Block Diagram

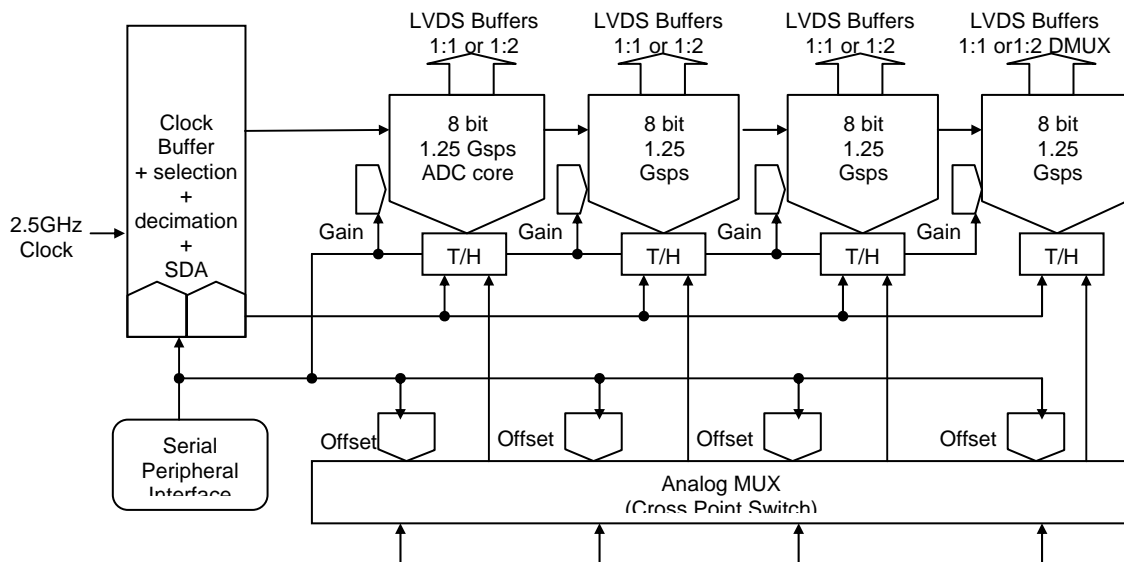

## 3. EV8AQ160 Description

The Quad ADC integrates four 8-bit ADC cores which can operate independently (4-channel mode) or grouped by 2 cores (2-channel mode with the ADCs interleaved two by two or 1-channel mode where all four ADCs are all interleaved).

All four ADCs are clocked by the same external input clock signal and controlled via an SPI (Serial Peripheral Interface). An analog multiplexer (Cross point Switch) is used to select the analog input depending on the mode the Quad ADC is used.

The Clock Circuit is common to all four ADCs. This block receives an external 2.5 GHz clock (maximum frequency) and preferably a low jitter symmetrical signal. In this block, the external clock signal is then divided by two in order to generate the internal sampling clocks:

- in 4-channel mode, the same 1.25 GHz clock is directed to all four ADC cores and T/H;
- in 2-channel mode, the in-phase 1.25 GHz clock is sent to ADC A or C and the inverted 1.25 GHz clock is sent to ADC B or D, while the analog input is sent to both ADCs, resulting in an interleaved mode with an equivalent sampling frequency of 2.5 Gsps.
- in 1-channel mode, the in-phase 1.25 GHz clock is sent to ADC A while the inverted 1.25 GHz clock is sent to ADC B, the in-phase 1.25 GHz clock is delayed by 90° to generate the clock for ADC C and the inverted 1.25 GHz clock is delayed by 90° to generate the clock for ADC D, resulting in an interleaved mode with an equivalent sampling frequency of 5 Gsps.

The clock circuit also implements a decimation function with a selectable factor (64, 16, 4 or 1). The factor is chosen via the SPI.

**Figure 2.** EV8AQ160TPY-DK Demo Kit system architecture (when connected with a VIRTEX6 Evaluation kit)

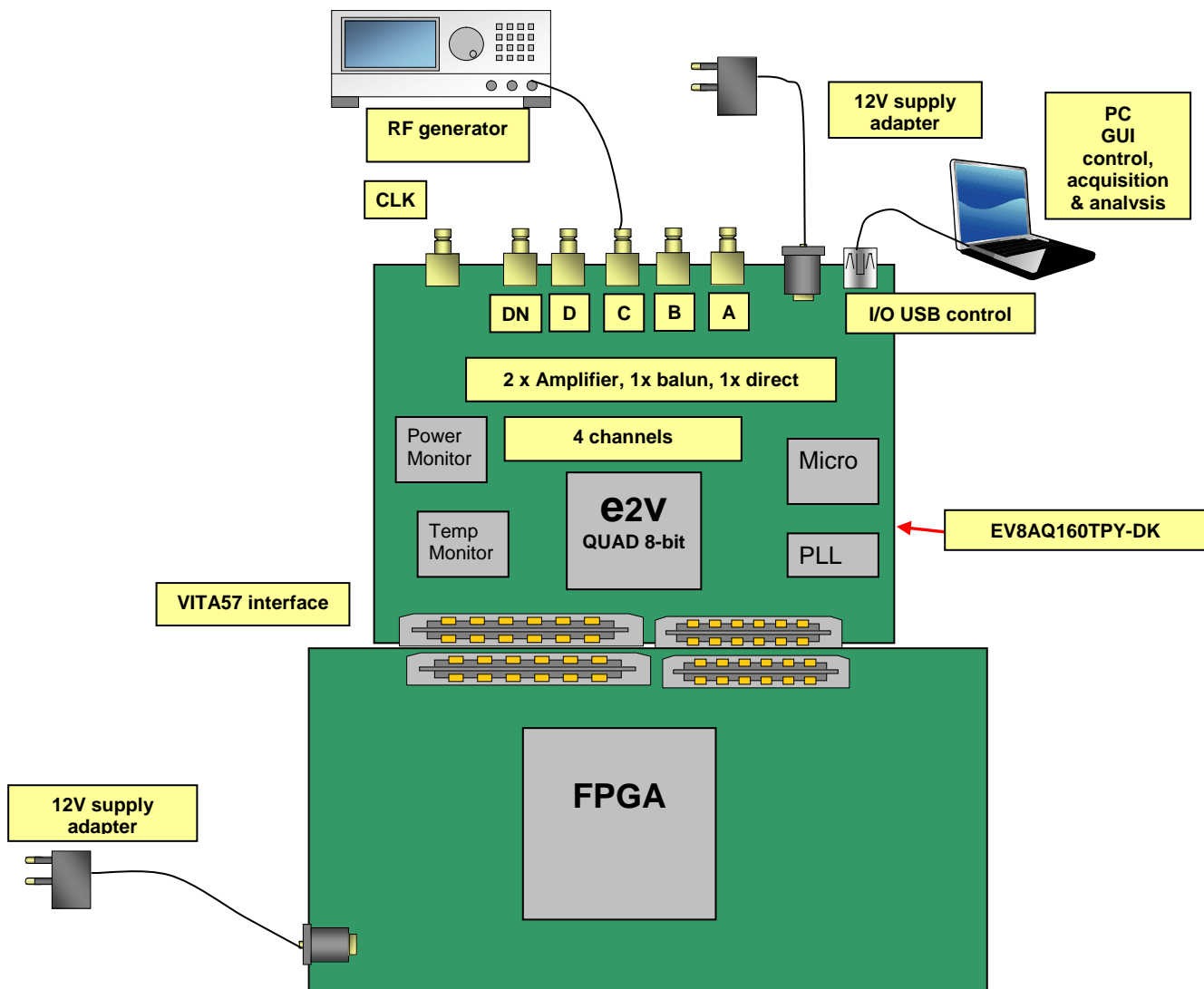

The complete system is built with the e2v demo kit and an FPGA development kit.

e2v Demo kit contains the following items :

- Quad 8-bit Demo kit with EV8AQ160CTPY
- Cables & Power Supply
  - Universal 12V power Adapter & Cables
  - USB Cable to communicate with a PC (control of ADC settings and settings for data acquisition)
- 4 analog inputs with SMA connectors
- 1 clock input with SMA connector (if external clock input is programming)
- 2 SAMTEC MC-HPC-8.5L connectors HPC (High Pin Count) compatible with VITA57 standard for ADC LVDS digital outputs
- CD ROM with GUI Software

Note: The ML605 VIRTEX 6 Evaluation kit with XC6VVLX240T-1FFG1156 FPGA is not supplied within the e2v kit and should be purchased separately from Xilinx or its authorised distributors.

**Figure 3.** EV8AQ160TPY-DK Demo Kit simplified schematic

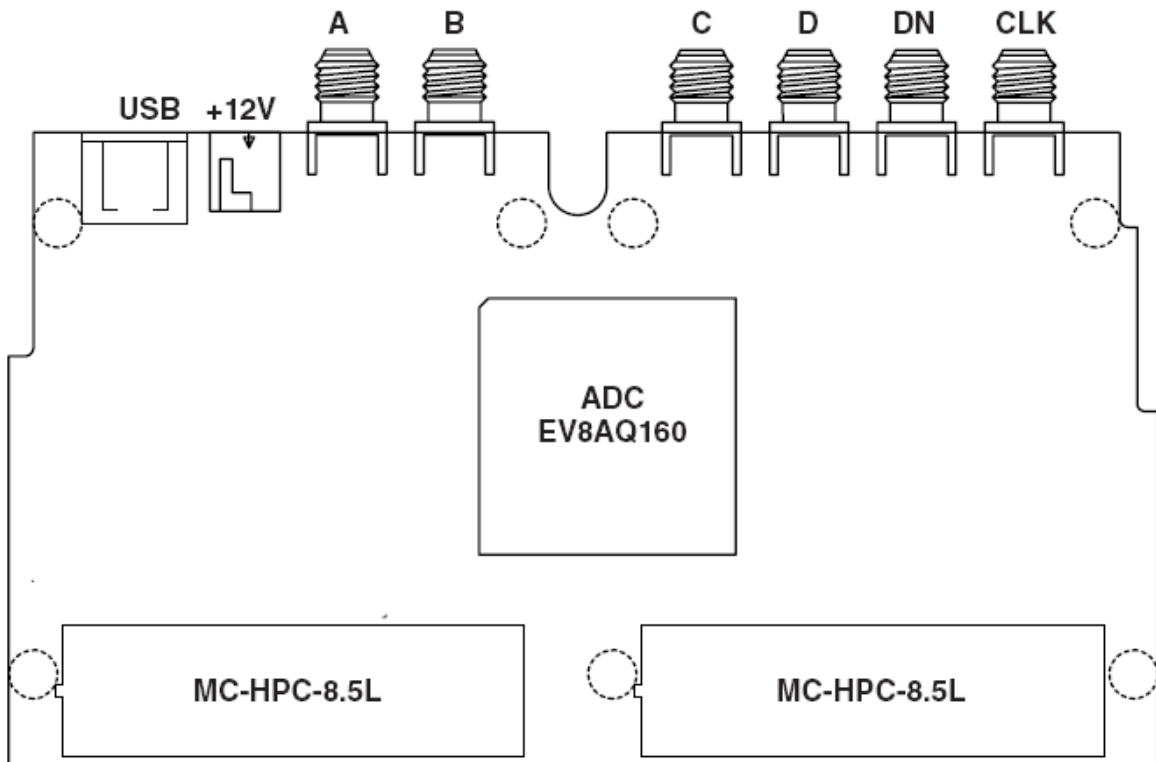

**Figure 4.** EV8AQ160TPY-DK Demo Kit functional architecture

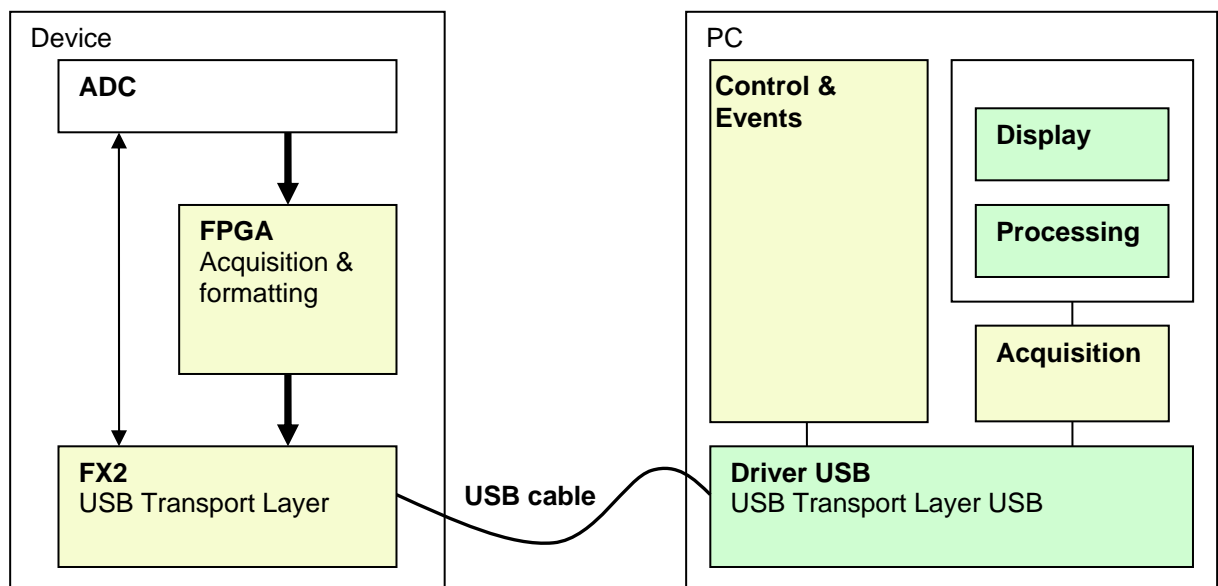

Acquisition and formatting of ADC digital output data are done within the FPGA Eval Kit.

Data is then transmitted again to the ADC Demo Kit.

A USB driver on the ADC Demo kit allows for transmission of the data to the computer that performs the display and processing of ADC output data (FFT).

Software and Graphical User Interface are provided with the Demo Kit.

The provided software operates using Labview RunTime (no license required).

## 4. Ordering Information

Table 1. Ordering information

Part Number	Package	Temperature Range	Screening Level	Comments
EV8AQ160TPY-DK	N/A	Ambient	N/A	